



# Grooving and Cut-Off

<b>Beyond Evolution • Grooving, Turning, and Cut-Off</b> .....	<b>C2–C77</b>
Application Guidelines .....	C76–C77
<b>A4 Groove and Turn</b> .....	<b>C78–C135</b>
<b>Top Notch • Shallow Grooving</b> .....	<b>C136–C179</b>
Application Guidelines .....	C172–C179

# Getting started made **EASY**

**beyond™ EVOLUTION™**

## Your day made **EASY**

Choosing the right tooling can be complicated and time-consuming. Built on simplicity, we have engineered a new tool that makes every machine operator's life **EASY**.

Unwilling to sacrifice performance or applications, Kennametal introduces Beyond™ Evolution™.

Beyond™ Evolution™ is the new single-side grooving and cut-off tool that also performs multi-directional turning.



## Productivity made **EASY**

### Active Coolant Control

If your coolant delivery is typical to the market, you may be applying more heat to the cutting edge than you think. This reduces tool life and increases cycle time.

With Beyond™ Evolution™, you won't have to change your existing equipment. Whether you are using a high-pressure or low-pressure coolant supply, Beyond™ Evolution™, featuring Active Coolant Control, delivers more tool life and higher Metal Removal Rates (MRR).

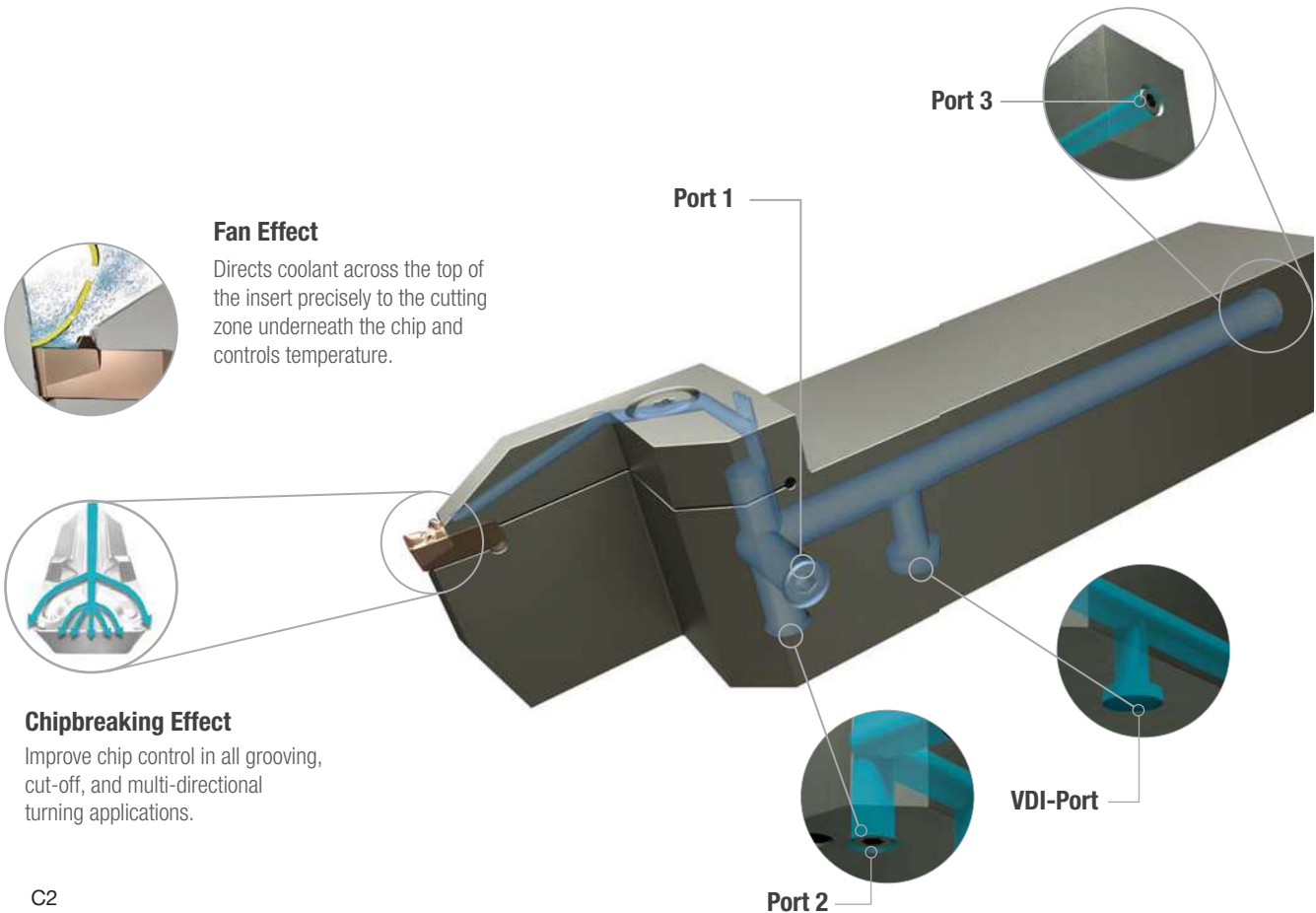

#### Fan Effect

Directs coolant across the top of the insert precisely to the cutting zone underneath the chip and controls temperature.

#### Chipbreaking Effect

Improve chip control in all grooving, cut-off, and multi-directional turning applications.

## Smooth surface finish made EASY Triple-V Seating

**Problem:** Traditional single-sided grooving and cut-off systems cannot deliver smooth surface finish due to lack of stability.

**Solution:** The Beyond™ Evolution™ proprietary new Triple-V Seating feature provides functional stability and minimises vibration.

**Three contact surfaces provide unmatched stability:**  
When combined with GUP and CF chipbreakers, Triple-V Seating provides excellent surface finish.

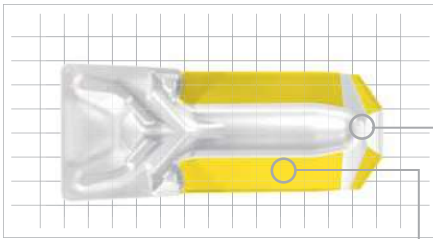

### Top and Bottom-V

Precise and secure insert positioning for increased rigidity and dimensional accuracy

### V-Back Design

Unsurpassed grooving, cut-off, and multi-directional turning load stability.

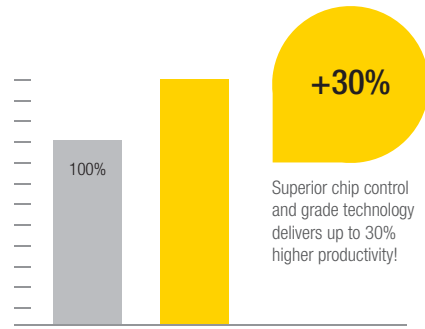
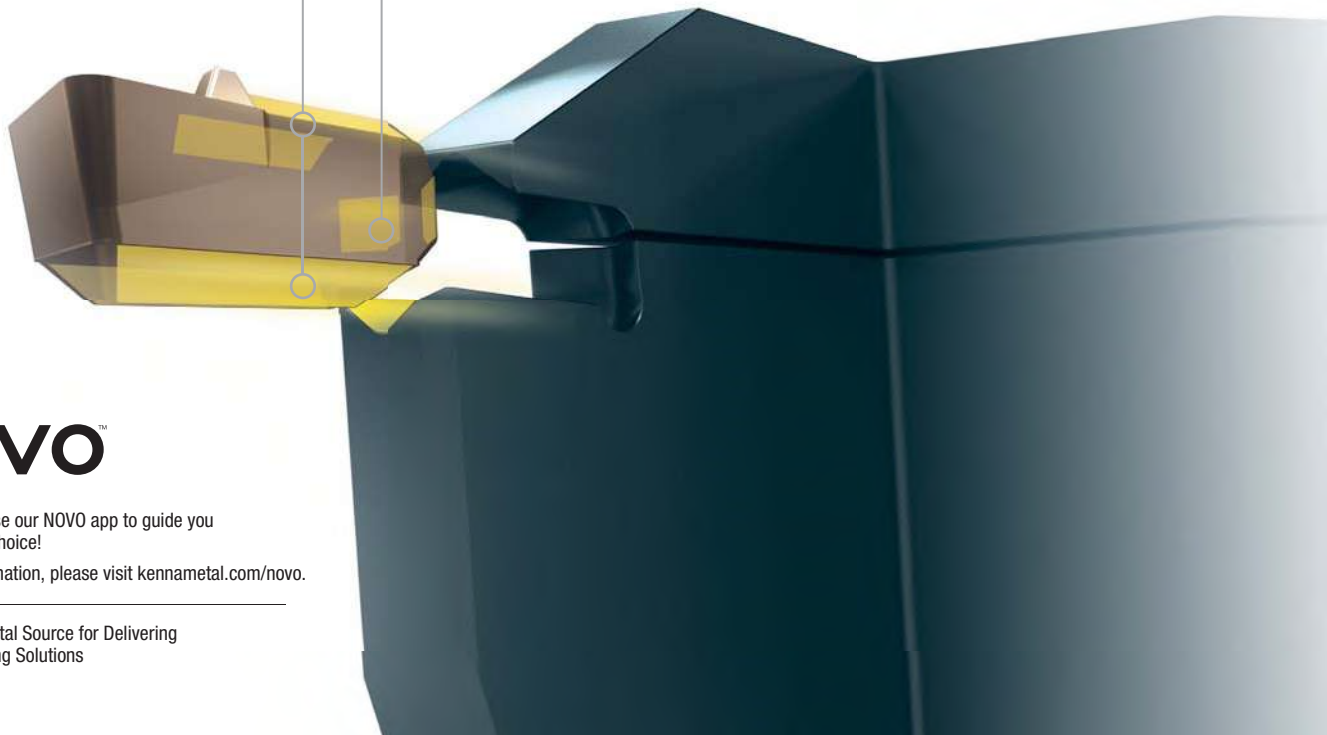

## Saving money made EASY

Beyond™ Evolution™, featuring Active Coolant Control, Triple-V Seating, and Beyond™ Drive™ grades with Wear Detection Technology, provides longer tool life, maximum stability, and higher Metal Removal Rates (MRR), resulting in up to 30% higher productivity.



You can also use our NOVO app to guide you to the correct choice!

For more information, please visit [kenametal.com/novo](http://kenametal.com/novo).

**NOVO:** The Digital Source for Delivering Smart Machining Solutions

# Your day made **EASY** —



Efficient coolant delivery.  
Available in seat sizes  
3 and higher.

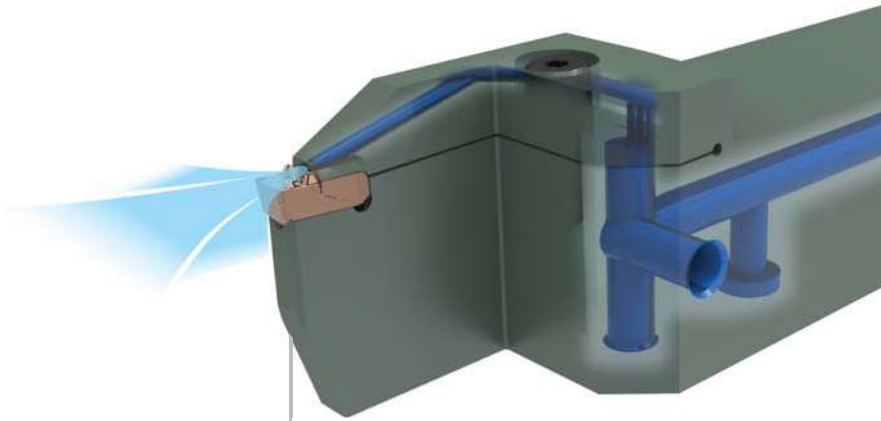

Modular with  
through coolant

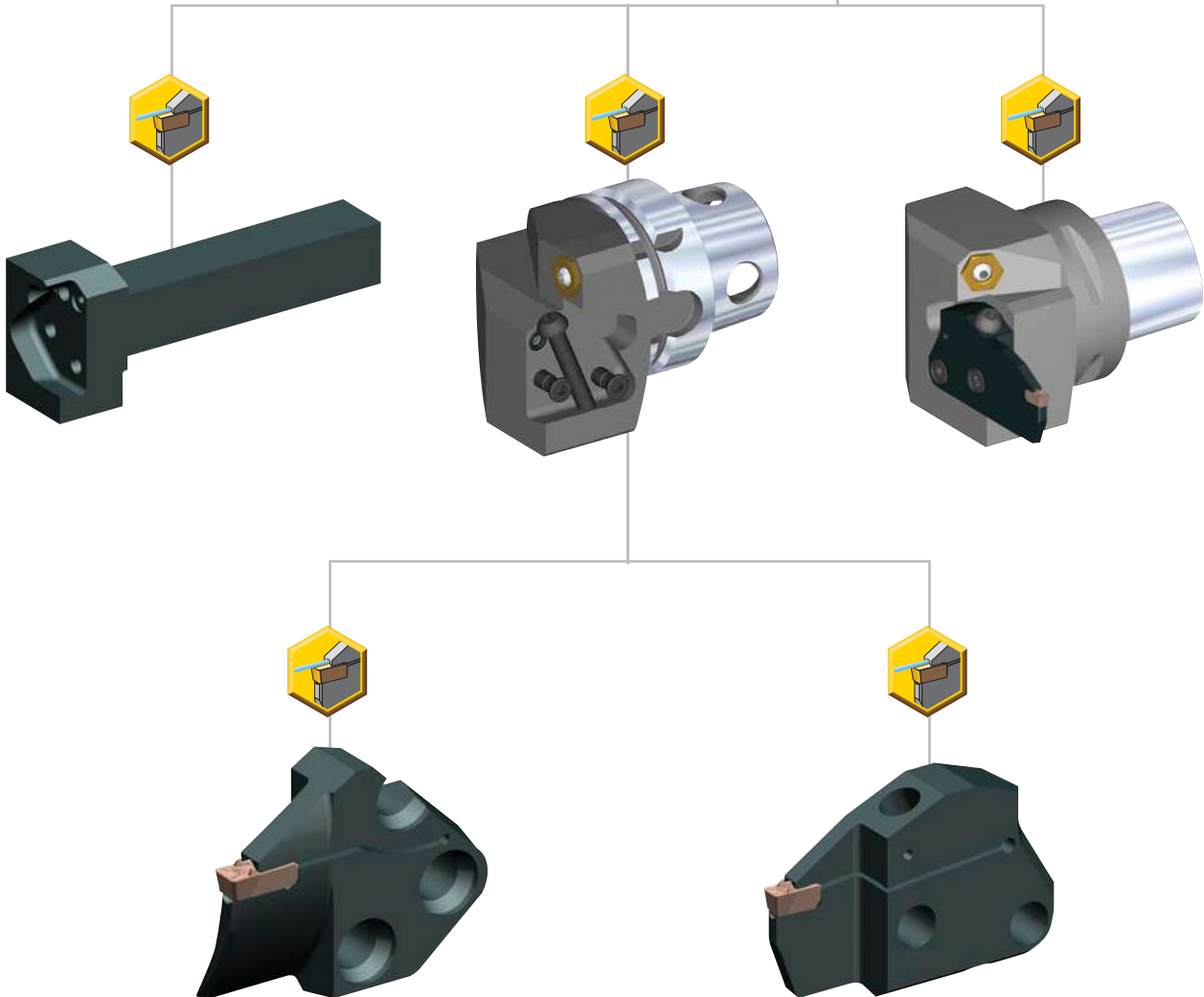



**EVOLUTION™**

# high-performance system.

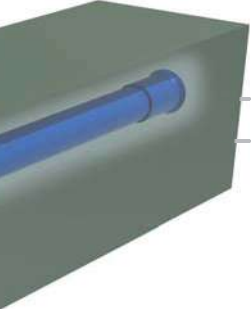

Face grooving  
with through coolant

I.D. Boring Bar

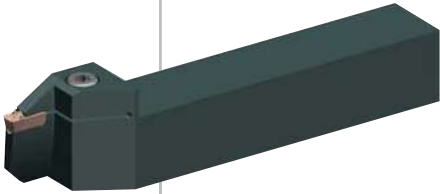

Square shank  
with through coolant



Cut-off blades

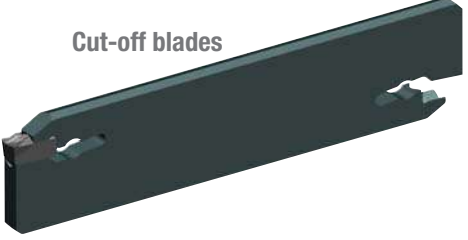
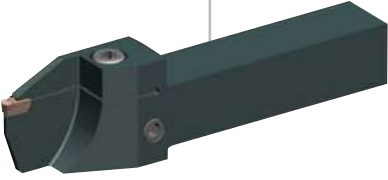
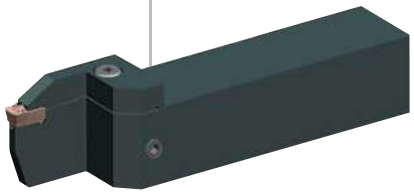

**Step 1 • Identify your grooving or cut-off application**

**What you need to know:**

- Groove depth, width, and profile.
- Material being machined.
- Application to be performed (O.D. and I.D. grooving, turning, face grooving, and cut-off).
- Shank size requirements of the machine.

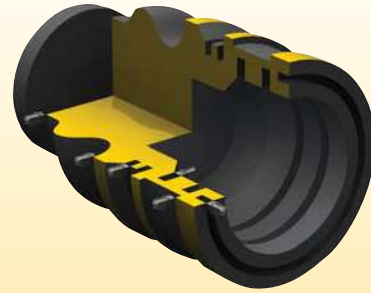

**General Recommendation to Select the Insert Size**

for workpiece diameters	insert seat size
<25mm	3
25–50mm	4
>50mm	5–10

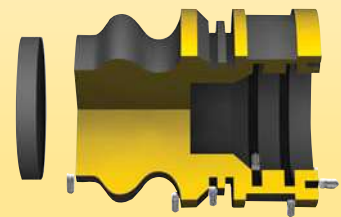

**Step 2 • Select chipbreaker style and feed rate**

Based on the application and seat size, determine the recommended geometry and starting feed rate.

**Plunge feed rates**

■ Steel  
■ Stainless Steel  
■ Cast Iron  
■ Non-Ferrous  
■ High-Temp Alloys  
■ Hardened Materials

● first choice  
 ○ alternate choice

Chip Control	Description	Insert Geometry	Seat Size	Corner Radius mm	Starting Conditions mm	Plunge Feed Rates mm/rw						
						0,05	0,10	0,15	0,20	0,25	0,30	0,35
-GUP	Positive rake angle for lower cutting forces.		1F	0,2	0,06							
			2	0,2	0,08							
			3	0,2	0,09							
				0,4	0,11							
			4	0,4	0,12							
				0,8	0,15							
			5	0,4	0,15							
				0,8	0,16							
			6	0,4	0,16							
				0,8	0,18							
-GUN	Stable negative cutting edge allowing for more aggressive applications.		1F	0,2	0,06							
			2	0,2	0,08							
			3	0,2	0,09							
				0,4	0,11							
			4	0,4	0,12							
				0,8	0,15							
			5	0,4	0,15							
				0,8	0,16							
			6	0,4	0,16							
				0,8	0,18							
	1,2	0,20										
	0,8	0,20										
	1,2	0,22										
	1,2	0,24										

**Maximum Feed Rate Values**

Material Group	Feed Factor
M	.8
N	1,2
S	.8
H	.5

Data above is for P and K material groups. Maximum feed rates should be adjusted by multiplying max feed rate values by following factors for shown material groups.

**I.D. and Face Grooving**  
For I.D. and face grooving applications, reduce feed rate by 20%.

### Step 3 • Select the starting speed

Based on material and grade, identify starting speed (vc). First choice is in **bold** type.

- A Based on material group and grade, identify starting speed (vc).
- B First choice starting speed is in **bold**.

		Recommended Starting Speeds [m/min]																	
Material Group		K313			KCU10			KCU25			KCM35B			KCP10B			KCP25B <sup>A</sup>		
P	0-1	-	-	-	140	<b>280</b>	350	110	<b>225</b>	270	90	<b>180</b>	213	185	<b>400</b>	450	145	<b>290</b>	365
	2	-	-	-	140	<b>200</b>	300	110	<b>160</b>	260	90	<b>130</b>	155	185	<b>270</b>	350	145	<b>200</b>	305
	3	-	-	-	140	<b>155</b>	245	110	<b>125</b>	235	90	<b>100</b>	155	170	<b>190</b>	260	140	<b>155</b>	245
	4	-	-	-	75	<b>110</b>	170	60	<b>90</b>	160	50	<b>70</b>	110	90	<b>145</b>	200	75	<b>110</b>	180
	5	-	-	-	120	<b>200</b>	260	100	<b>160</b>	210	80	<b>130</b>	165	150	<b>220</b>	305	120	<b>200</b>	270
	6	-	-	-	110	<b>150</b>	230	85	<b>120</b>	185	70	<b>100</b>	145	120	<b>180</b>	275	110	<b>150</b>	230
M	1	60	<b>90</b>	120	140	<b>210</b>	280	90	<b>170</b>	245	75	<b>120</b>	135	-	-	-	-	-	-
	2	45	<b>75</b>	110	120	<b>200</b>	245	90	<b>150</b>	245	75	<b>110</b>	135	-	-	-	-	-	-
	3	35	<b>65</b>	100	120	<b>180</b>	245	90	<b>140</b>	210	75	<b>90</b>	135	-	-	-	-	-	-
K	1	30	<b>75</b>	120	120	<b>180</b>	245	100	<b>145</b>	225	-	-	170	<b>245</b>	440	140	<b>200</b>	360	
	2	25	<b>70</b>	110	90	<b>150</b>	240	70	<b>120</b>	170	-	-	120	<b>195</b>	340	100	<b>160</b>	280	
	3	20	<b>60</b>	90	60	<b>110</b>	150	50	<b>85</b>	120	-	-	120	<b>170</b>	270	100	<b>140</b>	220	
1-2	150	<b>370</b>	610	150	<b>550</b>	975	120	<b>440</b>	780	-	-	-	-	-	-	-	-	-	

### Step 4 • Select toolholder based on application

Choose the high-performance holder based on your specific grooving or cut-off application, with the corresponding seat size.

Style		Application
	<b>Boring Bar</b>	• For use in I.D. grooving applications.
	<b>Cut-Off Blade</b>	• Allows user to vary the depth of cut.
	<b>Toolholder – Integral</b>	• Offers the most stability over other styles.
	<b>Toolholder – Modular</b>	• Interchangeable blades for versatility.
	<b>KM™ – Modular</b> <b>KM4X™ – Modular</b>	• Best-in-class KM™ Quick-Change platform.
	<b>PSC – Modular</b>	• The modular system in the PSC Quick-Change platform.

### Step 5 • Select the insert and holder from catalogue page

**Congratulations!**

You have successfully maximised your productivity by selecting the best insert geometry, grade, and cutting specifications for your application!

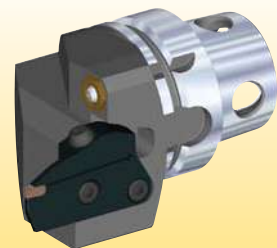



## How Do Catalogue Numbers Work?

Each character in our catalogue number signifies a specific trait of that product. Use the following key columns and corresponding images to easily identify which attributes apply.

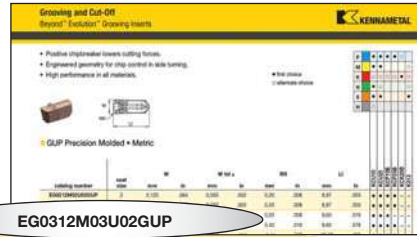

E	G	0312	M	03	U	02	GUP																																																								
<b>Family Name</b>	<b>Insert Type</b>	<b>Groove Width</b>	<b>Unit</b>	<b>Seat Size</b>	<b>Tolerance</b>	<b>Corner Radius</b>	<b>Chipbreaker/ Edge Condition</b>																																																								
Beyond™ Evolution™	G = Square  R = Full Radius	<b>Metric</b> = 1/100mm  <b>Inch</b> = 1/1000"	<b>M</b> = Metric  <b>I</b> = Inch		<b>U</b> = Precision Moulded  <b>P</b> = Precision Ground		<b>GUP</b> = Groove-Turn Universal Positive  <b>GUN</b> = Groove-Turn Universal Negative  <b>FB</b> = Flat Top Blank  <b>PB</b> = Positive Chip Control Blank																																																								
				<table border="1"> <thead> <tr> <th rowspan="2">seat size</th> <th colspan="2">groove width</th> </tr> <tr> <th>mm</th> <th>inch</th> </tr> </thead> <tbody> <tr> <td>1B</td> <td>1,40</td> <td>.055</td> </tr> <tr> <td>1F</td> <td>1,60–1,99</td> <td>.063–.078</td> </tr> <tr> <td>02</td> <td>2,00–2,99</td> <td>.079–.117</td> </tr> <tr> <td>03</td> <td>3,00–3,99</td> <td>.118–.156</td> </tr> <tr> <td>04</td> <td>4,00–4,99</td> <td>.157–.196</td> </tr> <tr> <td>05</td> <td>5,00–5,99</td> <td>.197–.235</td> </tr> <tr> <td>06</td> <td>6,00–7,99</td> <td>.236–.314</td> </tr> <tr> <td>08</td> <td>8,00–8,99</td> <td>.315–.353</td> </tr> <tr> <td>10</td> <td>9,00–10,12</td> <td>.354–.398</td> </tr> </tbody> </table> <p>*.312" = seat size 08</p>	seat size	groove width		mm	inch	1B	1,40	.055	1F	1,60–1,99	.063–.078	02	2,00–2,99	.079–.117	03	3,00–3,99	.118–.156	04	4,00–4,99	.157–.196	05	5,00–5,99	.197–.235	06	6,00–7,99	.236–.314	08	8,00–8,99	.315–.353	10	9,00–10,12	.354–.398	<table border="1"> <thead> <tr> <th colspan="2">mm</th> </tr> </thead> <tbody> <tr> <td>00</td> <td>full radius</td> </tr> <tr> <td>01</td> <td>0,1</td> </tr> <tr> <td>02</td> <td>0,2</td> </tr> <tr> <td>04</td> <td>0,4</td> </tr> <tr> <td>08</td> <td>0,8</td> </tr> <tr> <td>12</td> <td>1,2</td> </tr> </tbody> </table> <table border="1"> <thead> <tr> <th colspan="2">inch</th> </tr> </thead> <tbody> <tr> <td>00</td> <td>full radius</td> </tr> <tr> <td>05</td> <td>.008</td> </tr> <tr> <td>1</td> <td>.016</td> </tr> <tr> <td>2</td> <td>.032</td> </tr> <tr> <td>3</td> <td>.047</td> </tr> </tbody> </table>	mm		00	full radius	01	0,1	02	0,2	04	0,4	08	0,8	12	1,2	inch		00	full radius	05	.008	1	.016	2	.032	3	.047
seat size	groove width																																																														
	mm	inch																																																													
1B	1,40	.055																																																													
1F	1,60–1,99	.063–.078																																																													
02	2,00–2,99	.079–.117																																																													
03	3,00–3,99	.118–.156																																																													
04	4,00–4,99	.157–.196																																																													
05	5,00–5,99	.197–.235																																																													
06	6,00–7,99	.236–.314																																																													
08	8,00–8,99	.315–.353																																																													
10	9,00–10,12	.354–.398																																																													
mm																																																															
00	full radius																																																														
01	0,1																																																														
02	0,2																																																														
04	0,4																																																														
08	0,8																																																														
12	1,2																																																														
inch																																																															
00	full radius																																																														
05	.008																																																														
1	.016																																																														
2	.032																																																														
3	.047																																																														

By referencing this easy-to-use guide, you can identify the correct product to meet your needs.

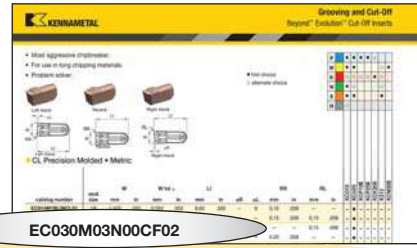

EC030M03N00CF02

<b>E</b>	<b>C</b>	<b>030</b>	<b>M</b>	<b>03</b>	<b>N</b>	<b>00</b>	<b>CF</b>	<b>02</b>																																																																
Family Name	Insert Type	Cutting Edge Width	Unit	Seat Size	Hand of Insert	Approach Angle	Chipbreaker	Corner Radius																																																																
Beyond™ Evolution™	<b>C</b> = Cut-Off		<b>M</b> = Metric <b>I</b> = Inch		<b>N</b> = Neutral <b>L</b> = Left hand <b>R</b> = Right hand	<b>00</b> = Neutral <b>06</b> = 6°	<b>CL</b> = Cut-Off Low Feed <b>CF</b> = Cut-Off Fine <b>CM</b> = Cut-Off Medium <b>CR</b> = Cut-Off Rough																																																																	
		<table border="1"> <thead> <tr> <th>Cutting Edge Width</th> <th>mm</th> <th>inch</th> </tr> </thead> <tbody> <tr><td>014</td><td>1,4</td><td>.055</td></tr> <tr><td>020</td><td>2,0</td><td>.079</td></tr> <tr><td>030</td><td>3,0</td><td>.118</td></tr> <tr><td>040</td><td>4,0</td><td>.157</td></tr> <tr><td>050</td><td>5,0</td><td>.197</td></tr> <tr><td>060</td><td>6,0</td><td>.236</td></tr> <tr><td>070</td><td>7,0</td><td>.279</td></tr> <tr><td>080</td><td>8,0</td><td>.315</td></tr> </tbody> </table>	Cutting Edge Width	mm	inch	014	1,4	.055	020	2,0	.079	030	3,0	.118	040	4,0	.157	050	5,0	.197	060	6,0	.236	070	7,0	.279	080	8,0	.315		<table border="1"> <thead> <tr> <th>Seat Size</th> <th>mm</th> <th>inch</th> </tr> </thead> <tbody> <tr><td>1B</td><td>1,4</td><td>.055</td></tr> <tr><td>1F</td><td>2,0</td><td>.079</td></tr> <tr><td>02</td><td>3,0</td><td>.118</td></tr> <tr><td>03</td><td>4,0</td><td>.157</td></tr> <tr><td>04</td><td>5,0</td><td>.197</td></tr> <tr><td>05</td><td>6,0</td><td>.236</td></tr> <tr><td>06</td><td>7,0</td><td>.279</td></tr> <tr><td>08</td><td>8,0</td><td>.315</td></tr> </tbody> </table>	Seat Size	mm	inch	1B	1,4	.055	1F	2,0	.079	02	3,0	.118	03	4,0	.157	04	5,0	.197	05	6,0	.236	06	7,0	.279	08	8,0	.315		<table border="1"> <thead> <tr> <th>Corner Radius</th> <th>mm</th> <th>inch</th> </tr> </thead> <tbody> <tr><td>01</td><td>0,1</td><td>.004</td></tr> <tr><td>02</td><td>0,2</td><td>.008</td></tr> <tr><td>04</td><td>0,4</td><td>.016</td></tr> </tbody> </table>	Corner Radius	mm	inch	01	0,1	.004	02	0,2	.008	04	0,4	.016
Cutting Edge Width	mm	inch																																																																						
014	1,4	.055																																																																						
020	2,0	.079																																																																						
030	3,0	.118																																																																						
040	4,0	.157																																																																						
050	5,0	.197																																																																						
060	6,0	.236																																																																						
070	7,0	.279																																																																						
080	8,0	.315																																																																						
Seat Size	mm	inch																																																																						
1B	1,4	.055																																																																						
1F	2,0	.079																																																																						
02	3,0	.118																																																																						
03	4,0	.157																																																																						
04	5,0	.197																																																																						
05	6,0	.236																																																																						
06	7,0	.279																																																																						
08	8,0	.315																																																																						
Corner Radius	mm	inch																																																																						
01	0,1	.004																																																																						
02	0,2	.008																																																																						
04	0,4	.016																																																																						

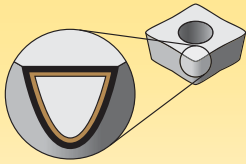

Coatings provide high-speed capability and are engineered for finishing to light roughing.

P	Steel
M	Stainless Steel
K	Cast Iron
N	Non-Ferrous
S	High-Temp Alloys
H	Hardened Materials

wear resistance ← → toughness

Grades	Coating	Grade Description	Performance Matrix																			
				05	10	15	20	25	30	35	40	45										
K313		<p><b>Composition:</b> A hard, low binder content, unalloyed WC/Co fine-grain grade.</p> <p><b>Application:</b> Exceptional edge wear resistance combined with very high strength for machining titanium, cast irons, austenitic stainless steels, non-ferrous metals, non-metals, and most high-temp alloys. Superior thermal deformation and depth-of-cut notch resistance. The grain structure is well controlled for minimal pits and flaws, which contributes to long, reliable service.</p>																				
			M																			
			K																			
KCU10		<p><b>Composition:</b> An advanced multilayer PVD coating over a very deformation-resistant unalloyed carbide substrate. The new and improved coating improves edge stability with wide range speed and feed capabilities.</p> <p><b>Application:</b> The KCU10™ grade is ideal for finishing to general machining of most workpiece materials at a wide range of speed and feed capabilities. Excellent for machining most steels, stainless steels, cast irons, non-ferrous materials, and super alloys with improved edge toughness and higher cutting speed/feed capability.</p>																				
			P																			
			M																			
KCU25		<p><b>Composition:</b> An advanced PVD grade with hard AlTiN coating and fine-grain unalloyed substrate. The new and improved coating improves edge stability with wide range speed and feed capabilities.</p> <p><b>Application:</b> The KCU25™ grade is ideal for general machining of most steels, stainless steels, high-temp alloys, titanium, irons, and non-ferrous materials in a wide range of speeds and feeds with improved edge toughness for interrupted cuts and high feed rates.</p>																				
			P																			
			M																			



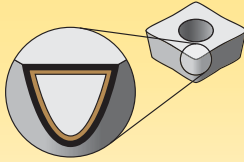





Coatings provide high-speed capability and are engineered for finishing to light roughing.

P	Steel
M	Stainless Steel
K	Cast Iron
N	Non-Ferrous
S	High-Temp Alloys
H	Hardened Materials

CVD-Coated Carbide Grades

Coating	Grade Description	wear resistance ← → toughness									
		05	10	15	20	25	30	35	40	45	
 KCP10B	<p><b>Composition:</b> A specially engineered wear-resistant carbide grade with a newly designed multilayer MTCVD-TiCN-Al<sub>2</sub>O<sub>3</sub>-TiOCN coating with superior interlayer adhesion.</p> <p><b>Application:</b> An excellent finishing to medium machining grade for a variety of workpiece materials, including most steels, ferritic, martensitic, and PH stainless steels, and cast irons. The cobalt-enriched substrate offers a balanced combination of deformation resistance and edge toughness, while the thick coating layers offer outstanding abrasion resistance and crater wear resistance for high-speed machining. Smooth coating provides resistance to edge build-up and microchipping and produces excellent surface finishes.</p>	P									
		K									
<b>beyond DRIVE™</b>											
 KCP25B	<p><b>Composition:</b> A tough cobalt-enriched carbide grade with a newly designed multilayer MTCVD-TiCN-Al<sub>2</sub>O<sub>3</sub>-TiOCN coating with superior interlayer adhesion.</p> <p><b>Application:</b> Best general-purpose turning grade for most steels and ferritic and martensitic stainless steels. The substrate design ensures adequate deformation resistance with excellent insert edge strength. Coating layers offer good wear resistance over a wide range of machining conditions and the post-coat treatment minimises microchipping and improves coating adhesion to substrate leading to long tool life and improved workpiece finishes.</p>	P									
		K									
<b>beyond DRIVE™</b>											
 KCK20B	<p><b>Composition:</b> A multilayered coating with thick MTCVD TiCN-Al<sub>2</sub>O<sub>3</sub>-TiOCN layers applied over a carbide substrate specifically engineered for cast irons.</p> <p><b>Application:</b> Delivers consistent performance in high-speed machining of grey and ductile irons. The substrate design permits the insert to stay in the cut for a long time at high speeds with minimum deformation. The thick CVD coating and post-coat treatment provide superior wear resistance ensuring long and consistent tool life. Can be applied both in straight and lightly interrupted cuts.</p>	P									
		K									
<b>beyond DRIVE™</b>											
 KCM35B	<p><b>Composition:</b> A multilayer TiN-MT-TiCN-Al<sub>2</sub>O<sub>3</sub>-TiOCN CVD coating over a super-tough substrate.</p> <p><b>Application:</b> KCM35B is an excellent general purpose to roughing grade for machining stainless steels and roughing steels in turning and cut-off applications. The substrate provides improved toughness while the coating layers offer improved abrasion resistance and dependability at high cutting temperatures, along with wear identification. The polished surface improves edge toughness and provides a smooth outer surface to reduce forces and resist workpiece build-up on the cutting edge even at low cutting speeds. The grade is available in multiple sizes and geometries appropriate for increased feeds and large depths of cut.</p>	P									
		M									
<b>beyond DRIVE™</b>											

### Select the geometry

<b>P</b>	Steel
<b>M</b>	Stainless Steel
<b>K</b>	Cast Iron
<b>N</b>	Non-Ferrous
<b>S</b>	High-Temp Alloys
<b>H</b>	Hardened Materials

- first choice
- alternate choice

Chip Control	Description	Insert Geometry	Seat Size	Corner Radius	Starting Conditions	Plunge Feed Rates inch/rev (mm/rev)						
				in (mm)	in (mm)	.0020 (0,05)	.0040 (0,10)	.0060 (0,15)	.0080 (0,20)	.0100 (0,25)	.0120 (0,30)	
-GUP	Positive rake angle for lower cutting forces.		1F	.008 (0,2)	.0024 (0,06)	◊						
			2	.008 (0,2)	.0031 (0,08)		◊					
			3	.008 (0,2)	.0035 (0,09)			◊				
				.016 (0,4)	.0043 (0,11)				◊			
			4	.016 (0,4)	.0047 (0,12)					◊		
				.031 (0,8)	.0059 (0,15)							

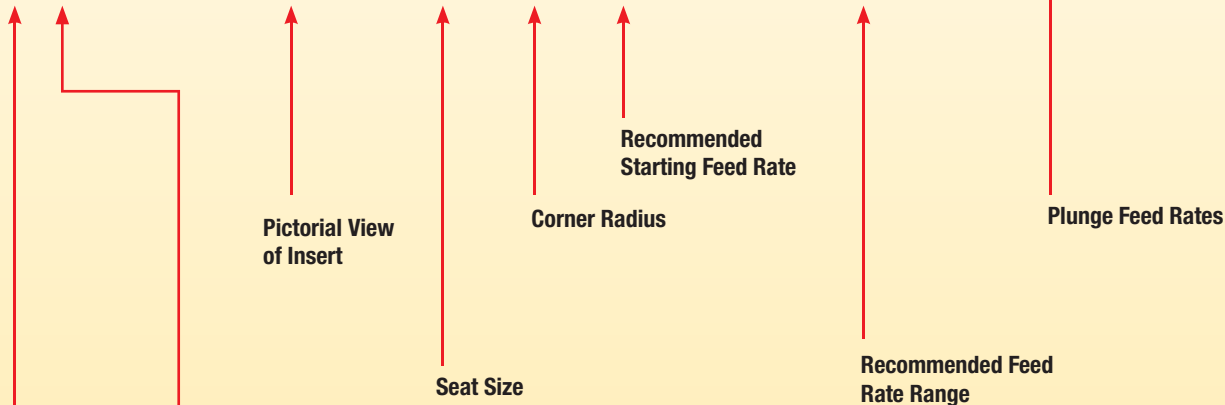

### Primary Workpiece Material Group

<b>P</b>	Steel
<b>M</b>	Stainless Steel
<b>K</b>	Cast Iron
<b>N</b>	Non-Ferrous
<b>S</b>	High-Temp Alloys
<b>H</b>	Hardened Materials

- first choice
- alternate choice

### Chip Control Geometry Designation

### Maximum Feed Rate Values

Data above is for P and K material groups. <b>Maximum</b> feed rates should be adjusted by multiplying max feed rate values by following factors for shown material groups.	Material Group	Feed Factor
	<b>M</b>	.8
	<b>N</b>	1.2
	<b>S</b>	.8
	<b>H</b>	.5

■ Plunge feed rates

P	Steel
M	Stainless Steel
K	Cast Iron
N	Non-Ferrous
S	High-Temp Alloys
H	Hardened Materials

- first choice
- alternate choice

Chip Control	Description	Insert Geometry	Seat Size	Corner Radius	Starting Conditions	Plunge Feed Rates mm/rev						
						0,05	0,10	0,15	0,20	0,25	0,30	0,35
-GUP	Positive rake angle for lower cutting forces.		1F	0,2	0,06	●	○					
			2	0,2	0,08	●	○					
			3	0,2	0,09	●	○					
				0,4	0,11	●	○					
			4	0,4	0,12	●	○					
				0,8	0,15	●	○					
			5	0,4	0,15	●	○					
				0,8	0,16	●	○					
			6	0,4	0,16	●	○					
				0,8	0,18	●	○					
8	1,2	0,20	●	○								
	0,8	0,20	●	○								
10	1,2	0,22	●	○								
	1,2	0,24	●	○								
-GUN	Stable negative cutting edge allowing for more aggressive applications.		1F	0,2	0,06	●	○					
			2	0,2	0,08	●	○					
			3	0,2	0,09	●	○					
				0,4	0,11	●	○					
			4	0,4	0,12	●	○					
				0,8	0,15	●	○					
			5	0,4	0,15	●	○					
				0,8	0,16	●	○					
			6	0,4	0,16	●	○					
				0,8	0,18	●	○					
8	1,2	0,20	●	○								
	0,8	0,20	●	○								
10	1,2	0,22	●	○								
	1,2	0,24	●	○								

Maximum Feed Rate Values

Data above is for P and K material groups. <b>Maximum</b> feed rates should be adjusted by multiplying max feed rate values by following factors for shown material groups.	Material Group	Feed Factor
	M	.8
	N	1.2
	S	.8
	H	.5

I.D. and Face Grooving

For I.D. and face grooving applications, reduce feed rate by 20%.

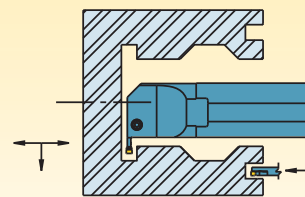

Turn and profile feed rates

Seat Size 1F

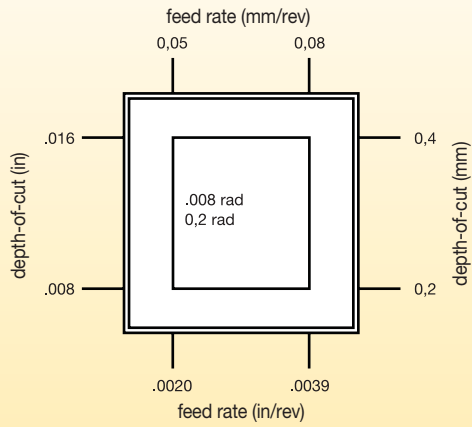

Seat Size 2

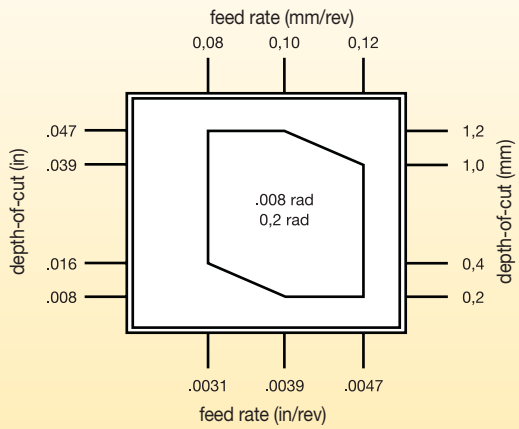

Seat Size 3

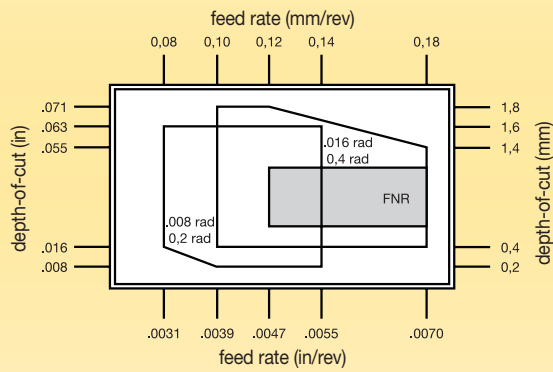

Seat Size 4

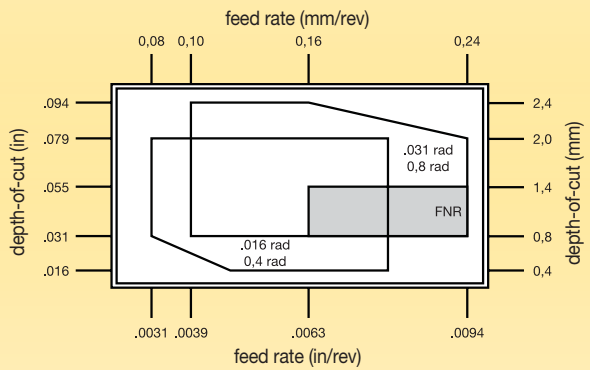

Seat Size 5

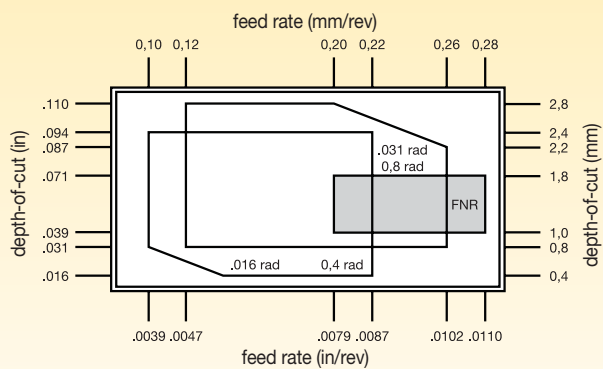

Seat Size 6

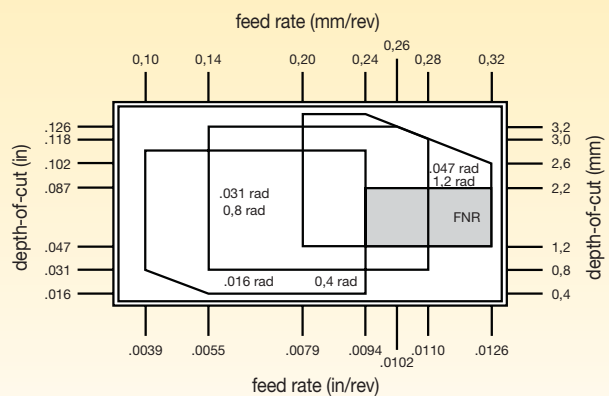

\* FNR = Full Nose Radius

(continued)

(Turn and profile feed rates — continued)

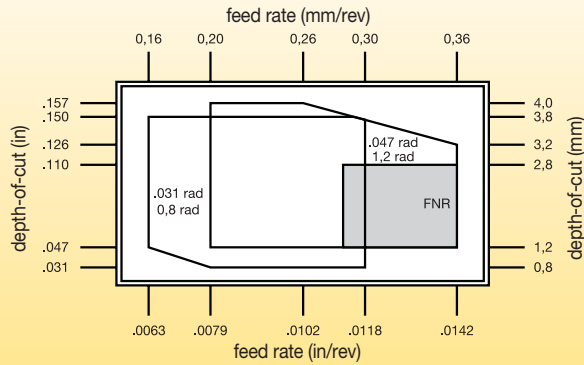
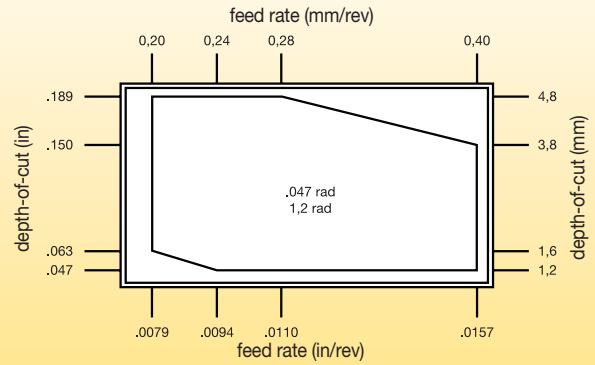
**Seat Size 8**

**Seat Size 10**

**Cut-Off Feed Rates**
**■ Plunge feed rates**

- first choice
- alternate choice

<b>P</b>	Steel
<b>M</b>	Stainless Steel
<b>K</b>	Cast Iron
<b>N</b>	Non-Ferrous
<b>S</b>	High-Temp Alloys
<b>H</b>	Hardened Materials

Geometry	Description	Insert Geometry	Seat Size	Starting Conditions mm	Cut-Off Feed Rates mm/rev								
					0,05	0,10	0,15	0,20	0,25	0,30	0,35	0,40	
-CL	Aggressive geometry for hard to break chips.		1B	0,06	●								
			2	0,07	●	○							
			3	0,08	●	○	○						
			4	0,09	●	○	○	○					
-CF	Positive geometry for reduced cutting forces.		1B	0,06	●								
			2	0,07	●	○							
			3	0,09	●	○	○						
			4	0,11	●	○	○	○					
			5	0,13	●	○	○	○	○				
-CM	Stable cutting edge for aggressive feed rates. Primarily in cast iron.		1B	0,06	●								
			2	0,07	●	○							
			3	0,09	●	○	○						
			4	0,11	●	○	○	○					
			5	0,14	●	○	○	○	○				
			6	0,16	●	○	○	○	○	○			
-CR	Most stable cutting edge for steel.		2	0,10	○	○							
			3	0,14	○	○	○						
			4	0,16	○	○	○	○					
			5	0,19	○	○	○	○	○				
6	0,21	○	○	○	○	○	○						
8	0,23	○	○	○	○	○	○	○					

NOTE: For cut-off inserts with a lead angle, maximum feed rate should be reduced by up to 40%.

**Maximum Feed Rate Values**

Data above is for P and K material groups. <b>Maximum</b> feed rates should be adjusted by multiplying max feed rate values by following factors for shown material groups.	Material Group	Feed Factor
	<b>M</b>	.8
	<b>N</b>	1.2
	<b>S</b>	.8
	<b>H</b>	.5



Recommended Starting Speeds [m/min]

Grooving and Cut-Off

Material Group		K313			KCU10			KCU25			KCM35B			KCP10B			KCP25B			KCK20B		
P	0-1	-	-	-	140	<b>280</b>	350	110	<b>225</b>	270	90	<b>180</b>	213	185	<b>400</b>	450	145	<b>290</b>	365	200	<b>440</b>	490
	2	-	-	-	140	<b>200</b>	300	110	<b>160</b>	260	90	<b>130</b>	155	185	<b>270</b>	350	145	<b>200</b>	305	200	<b>300</b>	380
	3	-	-	-	140	<b>155</b>	245	110	<b>125</b>	235	90	<b>100</b>	155	170	<b>190</b>	260	140	<b>155</b>	245	600	<b>200</b>	280
	4	-	-	-	75	<b>110</b>	170	60	<b>90</b>	160	50	<b>70</b>	110	90	<b>145</b>	200	75	<b>110</b>	180	100	<b>160</b>	220
	5	-	-	-	120	<b>200</b>	260	100	<b>160</b>	210	80	<b>130</b>	165	150	<b>220</b>	305	120	<b>200</b>	270	165	<b>240</b>	330
	6	-	-	-	110	<b>150</b>	230	85	<b>120</b>	185	70	<b>100</b>	145	120	<b>180</b>	275	110	<b>150</b>	230	130	<b>190</b>	300
M	1	60	<b>90</b>	120	140	<b>210</b>	280	90	<b>170</b>	245	75	<b>120</b>	135	-	-	-	-	-	-	-	-	-
	2	45	<b>75</b>	110	120	<b>200</b>	245	90	<b>150</b>	245	75	<b>110</b>	135	-	-	-	-	-	-	-	-	-
	3	35	<b>65</b>	100	120	<b>180</b>	245	90	<b>140</b>	210	75	<b>90</b>	135	-	-	-	-	-	-	-	-	-
K	1	30	<b>75</b>	120	120	<b>180</b>	245	100	<b>145</b>	225	-	-	-	170	<b>245</b>	440	140	<b>200</b>	360	210	<b>305</b>	550
	2	25	<b>70</b>	110	90	<b>150</b>	240	70	<b>120</b>	170	-	-	-	120	<b>195</b>	340	100	<b>160</b>	280	150	<b>245</b>	430
	3	20	<b>60</b>	90	60	<b>110</b>	150	50	<b>85</b>	120	-	-	-	120	<b>170</b>	270	100	<b>140</b>	220	150	<b>210</b>	335
N	1-2	150	<b>370</b>	610	150	<b>550</b>	975	120	<b>440</b>	780	-	-	-	-	-	-	-	-	-	-	-	-
	3	-	-	-	-	-	-	-	-	-	-	-	-	-	-	-	-	-	-	-	-	-
	4	120	<b>275</b>	430	120	<b>365</b>	700	100	<b>290</b>	490	-	-	-	-	-	-	-	-	-	-	-	-
	5	45	<b>90</b>	150	90	<b>170</b>	245	70	<b>135</b>	195	-	-	-	-	-	-	-	-	-	-	-	-
6	40	<b>75</b>	150	120	<b>210</b>	305	100	<b>170</b>	245	-	-	-	-	-	-	-	-	-	-	-	-	
S	1	8	<b>30</b>	75	15	<b>55</b>	135	8	<b>40</b>	60	8	<b>35</b>	60	-	-	-	-	-	-	-	-	-
	2	8	<b>35</b>	75	15	<b>60</b>	135	8	<b>30</b>	75	8	<b>30</b>	60	-	-	-	-	-	-	-	-	-
	3	8	<b>40</b>	75	15	<b>70</b>	150	15	<b>40</b>	75	15	<b>35</b>	60	-	-	-	-	-	-	-	-	-
	4	8	<b>45</b>	75	15	<b>70</b>	170	8	<b>50</b>	110	15	<b>45</b>	90	-	-	-	-	-	-	-	-	-
H	1	-	-	-	30	<b>45</b>	60	-	-	-	-	-	-	-	-	-	-	-	-	-	-	-
	2	-	-	-	15	<b>30</b>	45	-	-	-	-	-	-	-	-	-	-	-	-	-	-	-
	3	-	-	-	-	-	-	-	-	-	-	-	-	-	-	-	-	-	-	-	-	-

NOTE: FIRST choice starting speeds are in **bold** type.  
As the average chip thickness increases, the speed should be decreased.

# Mobile Apps

The Kennametal mobile app provides easy access to product information and calculators on both iPhone® and Android™ devices. We've highlighted a few of the key features...

There's an app for that.

### SPEEDS & FEEDS

View speeds and feeds information for metalworking products.

### PRODUCT AVAILABILITY

Check global availability of products. View available quantities by providing your Konnect login credentials.

### CALCULATORS

Utilise our machining calculators for milling and drilling applications.

By just scanning the bar code on the insert packet, you can find the most productive cutting conditions for tool life, process time, and chip control.

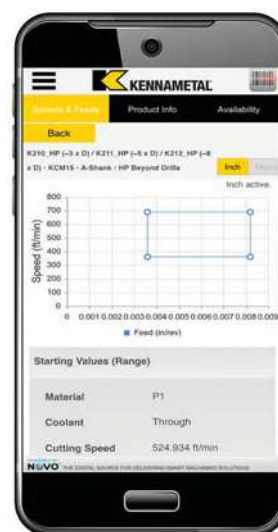

NOTE: The app is currently only available in the English-language version. We have plans to translate the app in different languages with future releases.



- Positive chipbreaker lowers cutting forces.
- Engineered geometry for chip control in side turning.
- High performance in all materials.

● first choice  
○ alternate choice

P	●	●	●	○					
M	●	●					●	○	
K	○	○	○	○	●	○			
N	●	○						●	
S	●	●						●	
H	○								

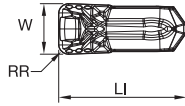

### ■ GUP Precision Moulded • Metric

catalogue number	seat size	W	W tol ±	RR	LI	KCU10	KCU25	KCP10B	KCP25B	KCK20B	KCM35B	K313
EG0212M02U02GUP	2	2,125	0,050	0,20	8,97	●	●	●	●	-	-	-
EG0251M02U02GUP	2	2,511	0,050	0,20	8,97	●	●	●	●	-	-	-
EG0312M03U02GUP	3	3,125	0,075	0,20	9,60	●	●	●	-	-	-	-
EG0312M03U04GUP	3	3,125	0,075	0,40	9,60	●	●	●	-	-	-	-
EG0412M04U04GUP	4	4,125	0,075	0,40	10,19	●	●	●	-	-	-	-
EG0412M04U08GUP	4	4,125	0,075	0,80	10,19	●	●	●	-	-	-	-
EG0512M05U04GUP	5	5,125	0,075	0,40	12,25	●	●	●	-	-	-	-
EG0512M05U08GUP	5	5,125	0,075	0,80	12,25	●	●	●	-	-	-	-
EG0612M06U04GUP	6	6,125	0,075	0,40	14,60	●	●	●	-	-	-	-
EG0612M06U08GUP	6	6,125	0,075	0,80	14,60	●	●	●	-	-	-	-
EG0712M06U08GUP	6	7,125	0,075	0,80	14,60	●	●	●	-	-	-	-
EG0812M08U08GUP	8	8,125	0,075	0,80	17,47	●	●	●	-	-	-	-
EG0812M08U12GUP	8	8,125	0,075	1,18	17,45	●	●	●	-	-	-	-
EG1012M10U12GUP	10	10,125	0,075	1,20	20,80	●	●	●	-	-	-	-



- Positive chipbreaker lowers cutting forces.
- Engineered geometry for chip control in side turning.
- High performance in all materials.
- More precise widths and better repeatability.

● first choice  
○ alternate choice

P	●	●	●	●	○							
M	●	●	●	●	○							
K	○	○	○	○	●							
N	●	○	●	●	●							
S	●	●	●	●	●							
H	○											

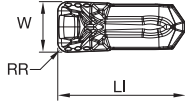

### ■ GUP Precision Ground • Metric

catalogue number	seat size	W	W tol ±	RR	LI	KCU10	KCU25	KCP10B	KCP25B	KCK20B	KCM35B	K313
EG0200M02P02GUP	2	2,000	0,025	0,20	8,80	●	●	-	-	-	-	●
EG0300M03P02GUP	3	3,000	0,025	0,20	9,40	●	●	-	-	-	-	●
EG0300M03P04GUP	3	3,000	0,025	0,40	9,60	●	●	-	-	-	-	●
EG0400M04P04GUP	4	4,000	0,025	0,40	10,10	●	●	-	-	-	-	●
EG0400M04P08GUP	4	4,000	0,025	0,80	10,10	●	●	-	-	-	-	●
EG0500M05P04GUP	5	5,000	0,025	0,40	12,20	●	●	-	-	-	-	●
EG0500M05P08GUP	5	5,000	0,025	0,80	12,20	●	●	-	-	-	-	●
EG0600M06P04GUP	6	6,000	0,025	0,40	14,50	●	●	-	-	-	-	●
EG0600M06P08GUP	6	6,000	0,025	0,80	14,50	●	●	-	-	-	-	●
EG0700M06P08GUP	6	7,000	0,025	0,80	14,50	●	●	-	-	-	-	●
EG0800M08P08GUP	8	8,000	0,025	0,80	17,40	●	●	-	-	-	-	●
EG0800M08P12GUP	8	8,000	0,025	1,20	17,40	●	●	-	-	-	-	●
EG1000M10P12GUP	10	10,000	0,025	1,20	20,70	●	●	-	-	-	-	●

Grooving and Cut-Off

- Positive chipbreaker lowers cutting forces.
- Engineered geometry for chip control in side turning.
- High performance in all materials.

● first choice  
○ alternate choice

P	●	●	●	○					
M	●	●						●	○
K	○	○	○	○	●	○			
N	●	○							●
S	●	●							●
H	○								

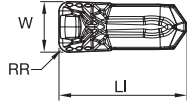

### ■ GUP Precision Moulded • Inch

catalogue number	seat size	W	W tol ±	RR	LI	KCU10	KCU25	KCP10B	KCP25B	KCK20B	KCM35B	K313
EG130I03U05GUP	3	3,301	0,075	0,20	9,60	●	●	●	●	-	-	-
EG130I03U1GUP	3	3,301	0,075	0,40	9,60	●	●	●	●	-	-	-
EG192I04U1GUP	4	4,877	0,075	0,40	10,19	●	●	●	●	-	-	-
EG192I04U2GUP	4	4,877	0,075	0,79	10,19	●	●	●	●	-	-	-
EG255I06U1GUP	6	6,478	0,075	0,40	14,58	●	●	●	●	-	-	-
EG255I06U2GUP	6	6,478	0,075	0,80	14,58	●	●	●	●	-	-	-
EG317I08U3GUP	8	8,051	0,075	1,19	17,46	●	●	●	●	-	-	-
EG380I10U3GUP	10	9,651	0,075	1,19	20,80	●	●	●	●	-	-	-



- Positive chipbreaker lowers cutting forces.
- Engineered geometry for chip control in side turning.
- High performance in all materials.
- More precise widths and better repeatability.

● first choice  
○ alternate choice

P	●	●	●	●	○						
M	●	●								●	○
K	○	○	○	○	○	●	○				
N	●	○									●
S	●	●									●
H	○										

Grooving and Cut-Off

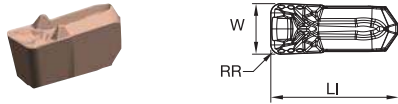

■ GUP Precision Ground • Inch

catalogue number	seat size	W	W tol ±	RR	LI	KCU10	KCU25	KCP10B	KCP25B	KCK20B	KCM35B	K313
EG06311FP05GUP	1F	1,600	0,025	0,20	9,00	●	●	-	-	-	-	●
EG094I02P05GUP	2	2,388	0,025	0,20	8,88	●	●	-	-	-	-	●
EG125I03P05GUP	3	3,175	0,025	0,20	9,40	●	●	-	-	-	-	●
EG125I03P1GUP	3	3,175	0,025	0,40	9,40	●	●	-	-	-	-	●
EG187I04P1GUP	4	4,760	0,025	0,40	10,10	●	●	-	-	-	-	●
EG187I04P2GUP	4	4,762	0,025	0,79	10,10	●	●	-	-	-	-	●
EG250I06P1GUP	6	6,350	0,025	0,40	14,50	●	●	-	-	-	-	●
EG250I06P2GUP	6	6,350	0,025	0,80	14,50	●	●	-	-	-	-	●
EG312I08P3GUP	8	7,920	0,025	1,20	17,40	●	●	-	-	-	-	●
EG375I10P3GUP	10	9,525	0,025	1,20	20,70	●	●	-	-	-	-	●

- First choice in profiling.
- >180° cutting edge.
- High performance in all materials.

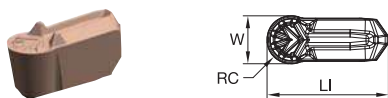

■ GUP Full Radius Precision Moulded • Metric

catalogue number	seat size	W	W tol ±	RC	LI	KCU10	KCU25	KCP10B	KCP25B	KCK20B	KCM35B	K313
ER0312M03U00GUP	3	3,125	0,075	1,560	9,60	●	●	●	●	-	-	-
ER0412M04U00GUP	4	4,125	0,075	2,060	10,20	●	●	●	●	-	-	-
ER0512M05U00GUP	5	5,125	0,075	2,560	12,20	●	●	●	●	-	-	-
ER0612M06U00GUP	6	6,125	0,075	3,060	14,60	●	●	●	●	-	-	-
ER0812M08U00GUP	8	8,125	0,075	4,060	17,50	●	●	●	●	-	-	-

- First choice in profiling.
- >180° cutting edge.
- High performance in all materials.
- More precise widths and better repeatability.

● first choice  
○ alternate choice

P	●	●	●	○	○	○	○
M	●	●	○	○	○	○	○
K	○	○	○	○	○	○	○
N	●	○	○	○	○	○	○
S	●	●	○	○	○	○	○
H	○	○	○	○	○	○	○

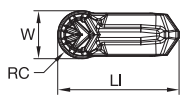

■ GUP Full Radius Precision Ground • Metric

catalogue number	seat size	W	W tol ±	RC	LI	KCU10	KCU25	KCP10B	KCP25B	KCK20B	KCM35B	K313
ER0300M03P00GUP	3	3,000	0,025	1,500	9,50	●	●	-	-	-	-	●
ER0400M04P00GUP	4	4,000	0,025	2,000	10,10	●	●	-	-	-	-	●
ER0500M05P00GUP	5	5,000	0,025	2,500	12,20	●	●	-	-	-	-	●
ER0600M06P00GUP	6	6,000	0,025	3,000	14,50	●	●	-	-	-	-	●
ER0800M08P00GUP	8	8,000	0,025	4,000	17,40	●	●	-	-	-	-	●

- First choice in profiling.
- >180° cutting edge.
- High performance in all materials.

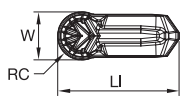

■ GUP Full Radius Precision Moulded • Inch

catalogue number	seat size	W	W tol ±	RC	LI	KCU10	KCU25	KCP10B	KCP25B	KCK20B	KCM35B	K313
ER130I03U00GUP	3	3,302	0,075	1,650	9,60	●	●	●	●	-	-	-
ER192I04U00GUP	4	4,878	0,075	2,440	10,20	●	●	●	●	-	-	-
ER255I06U00GUP	6	6,478	0,075	3,240	14,60	●	●	●	●	-	-	-
ER317I08U00GUP	8	8,052	0,075	4,030	17,50	●	●	●	●	-	-	-

- First choice in profiling.
- >180° cutting edge.
- High performance in all materials.
- More precise widths and better repeatability.

- first choice
- alternate choice

P	●	●	●	●	○					
M	●	●	●	●	●	○				
K	○	○	○	○	●	○				
N	●	○	○	○	○	○				●
S	●	●	○	○	○	○				●
H	○									

Grooving and Cut-Off

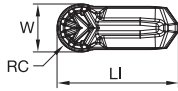

### ■ GUP Full Radius Precision Ground • Inch

catalogue number	seat size	W	W tol ±	RC	LI	KCU10	KCU25	KCP10B	KCP25B	KCK20B	KCM35B	K313
ER125I03P00GUP	3	3,175	0,025	1,590	9,50	●	●	-	-	-	-	●
ER187I04P00GUP	4	4,762	0,025	2,380	10,10	●	●	-	-	-	-	●
ER250I06P00GUP	6	6,350	0,025	3,170	14,50	●	●	-	-	-	-	●
ER312I08P00GUP	8	7,920	0,025	3,960	17,40	●	●	-	-	-	-	●

- Negative rake face for strongest cutting edge.
- More aggressive applications.
- Advantages in low-feed and depth-of-cut applications.

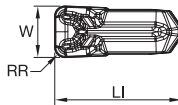

### ■ GUN Precision Moulded • Metric

catalogue number	seat size	W	W tol ±	RR	LI	KCU10	KCU25	KCP10B	KCP25B	KCK20B	KCM35B	K313
EG0212M02U02GUN	2	2,125	0,050	0,20	8,97	●	●	●	●	●	-	-
EG0251M02U02GUN	2	2,510	0,050	0,20	8,97	●	●	●	●	●	-	-
EG0312M03U02GUN	3	3,125	0,075	0,20	9,60	●	●	●	●	●	-	-
EG0312M03U04GUN	3	3,125	0,075	0,40	9,60	●	●	●	●	●	-	-
EG0412M04U04GUN	4	4,125	0,075	0,40	10,19	●	●	●	●	●	-	-
EG0412M04U08GUN	4	4,125	0,075	0,80	10,19	●	●	●	●	●	-	-
EG0512M05U04GUN	5	5,125	0,075	0,40	12,20	●	●	●	●	●	-	-
EG0512M05U08GUN	5	5,125	0,075	0,80	12,20	●	●	●	●	●	-	-
EG0612M06U04GUN	6	6,125	0,075	0,40	14,60	●	●	-	●	●	-	-
EG0612M06U08GUN	6	6,125	0,075	0,80	14,60	●	●	-	●	●	-	-
EG0812M08U08GUN	8	8,125	0,075	0,80	17,50	●	●	●	●	●	-	-
EG0812M08U12GUN	8	8,125	0,075	1,20	17,50	●	●	●	●	●	-	-
EG1012M10U12GUN	10	10,125	0,075	1,20	20,80	●	●	●	●	●	-	-

- Negative rake face for strongest cutting edge.
- More aggressive applications.
- Advantages in low-feed and depth-of-cut applications.

● first choice  
○ alternate choice

P	●	●	●	●	○	○	○	○
M	●	●	○	○	○	○	○	○
K	○	○	○	○	○	○	○	○
N	●	○	○	○	○	○	○	○
S	●	●	○	○	○	○	○	○
H	○	○	○	○	○	○	○	○

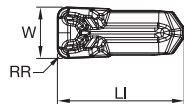

■ GUN Precision Moulded • Inch

catalogue number	seat size	W	W tol ±	RR	LI	KCU10	KCU25	KCP10B	KCP25B	KCK20B	KCM35B	K313
EG06311FU05GUN	1F	1,600	0,050	0,20	9,00	●	●	●	●	○	○	○
EG130I03U05GUN	3	3,302	0,075	0,20	9,60	●	●	●	●	○	○	○
EG130I03U1GUN	3	3,302	0,075	0,40	9,60	●	●	●	●	○	○	○
EG192I04U1GUN	4	4,877	0,075	0,40	10,19	●	●	●	●	○	○	○
EG192I04U2GUN	4	4,878	0,075	0,79	10,19	●	●	●	●	○	○	○
EG255I06U1GUN	6	6,477	0,075	0,40	14,58	●	●	●	●	○	○	○
EG255I06U2GUN	6	6,477	0,075	0,80	14,58	●	●	●	●	○	○	○
EG317I08U3GUN	8	8,052	0,075	1,19	17,46	●	●	●	●	○	○	○
EG380I10U3GUN	10	9,651	0,075	1,20	20,80	●	●	●	●	○	○	○

- Negative rake face for strongest cutting edge.
- First choice in profiling.
- >180° cutting edge.
- High performance in all materials.

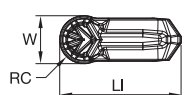

■ GUN Full Radius Precision Moulded • Metric

catalogue number	seat size	W	W tol ±	RC	LI	KCU10	KCU25	KCP10B	KCP25B	KCK20B	KCM35B	K313
ER0312M03U00GUN	3	3,125	0,075	1,560	9,60	●	●	●	●	○	○	○
ER0412M04U00GUN	4	4,125	0,075	2,060	10,20	●	●	●	●	○	○	○
ER0512M05U00GUN	5	5,125	0,075	2,560	12,20	●	●	●	●	○	○	○
ER0612M06U00GUN	6	6,125	0,075	3,060	14,60	●	●	●	●	○	○	○
ER0812M08U00GUN	8	8,125	0,075	4,060	17,47	●	●	●	●	○	○	○

Grooving and Cut-Off



- Negative rake face for strongest cutting edge.
- First choice in profiling.
- >180° cutting edge.
- High performance in all materials.

- first choice
- alternate choice

P	●	●	●	●	○						
M	●	●	●	●	○						
K	○	○	○	○	○	●	●	○			
N	●	○	○	○	○	○	○	○	○	○	○
S	●	●	○	○	○	○	○	○	○	○	○
H	○	○	○	○	○	○	○	○	○	○	○

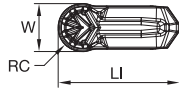

■ GUN Full Radius Precision Moulded • Inch

catalogue number	seat size	W	W tol ±	RC	LI	KCU10	KCU25	KCP10B	KCP25B	KCK20B	KCM35B	K313
ER094I02U00GUN	2	2,387	0,050	1,190	8,97	●	●	●	●	○	○	○
ER125I03U00GUN	3	3,177	0,075	1,590	9,60	●	●	●	●	○	○	○
ER130I03U00GUN	3	3,300	0,075	1,650	9,60	●	●	●	●	○	○	○
ER187I04U00GUN	4	4,750	0,075	2,370	10,20	●	●	●	●	○	○	○
ER192I04U00GUN	4	4,873	0,075	2,440	10,20	●	●	●	●	○	○	○
ER250I06U00GUN	6	6,346	0,075	3,170	14,60	●	●	●	●	○	○	○
ER255I06U00GUN	6	6,473	0,075	3,240	14,60	●	●	●	●	○	○	○
ER312I08U00GUN	8	7,925	0,075	3,960	17,50	●	●	●	●	○	○	○
ER317I08U00GUN	8	8,052	0,075	4,030	17,50	●	●	●	●	○	○	○

- Positive chipbreaker lowers cutting forces.
- First choice for steel and stainless steel.
- Excellent surface finish.

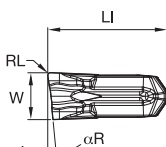
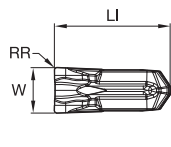
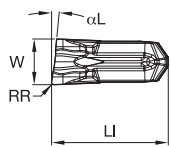

■ CF Precision Moulded • Metric

catalogue number	seat size	W	W tol ±	LI	αR	αL	RR	RL	KCU10	KCU25	KCP10B	KCP25B	KCK20B	KCM35B	K313
EC014M1BL06CF01	1B	1,404	0,050	9,00	—	6	0,15	—	—	●	—	—	—	●	—
EC014M1BN00CF01	1B	1,400	0,050	9,00	—	—	0,15	0,15	—	●	—	—	—	●	—
EC014M1BR06CF01	1B	1,404	0,050	9,00	6	—	—	0,15	—	●	—	—	—	●	—
EC020M02L06CF02	2	2,000	0,050	8,97	—	6	0,20	—	—	●	—	—	—	●	—
EC020M02N00CF02	2	2,000	0,050	8,97	—	—	0,20	0,20	—	●	—	—	—	●	—
EC020M02R06CF02	2	2,000	0,050	8,97	6	—	—	0,20	—	●	—	—	—	●	—
EC030M03L06CF02	3	3,000	0,075	9,60	—	6	0,20	—	—	●	—	—	—	●	—
EC030M03N00CF02	3	3,000	0,075	9,60	—	—	0,20	0,20	—	●	—	—	—	●	—
EC030M03R06CF02	3	3,000	0,075	9,60	6	—	—	0,20	—	●	—	—	—	●	—
EC040M04L06CF02	4	4,000	0,075	10,19	—	6	0,20	—	—	●	—	—	—	●	—
EC040M04N00CF02	4	4,000	0,075	10,19	—	—	0,20	0,20	—	●	—	—	—	●	—
EC040M04R06CF02	4	4,000	0,075	10,19	6	—	—	0,20	—	●	—	—	—	●	—
EC050M05N00CF03	5	5,000	0,075	12,20	—	—	0,30	0,30	—	●	—	—	—	●	—

- Most aggressive chipbreaker.
- For use in long chipping materials.
- Problem solver.

- first choice
- alternate choice

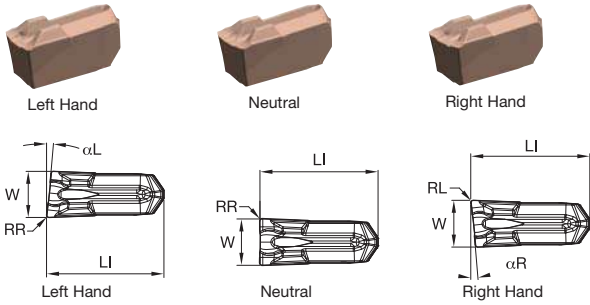

### CL Precision Moulded • Metric

catalogue number	seat size	W	W tol ±	LI	αR	αL	RR	RL	KCU10	KCU25	KCP10B	KCP25B	KCK20B	KCM35B	K313
EC014M1BL06CL01	1B	1,400	0,050	9,00	—	6	0,15	—	●	●	○	○	○	○	○
EC014M1BN00CL01	1B	1,400	0,050	9,00	—	—	0,15	0,15	●	●	○	○	○	○	○
EC014M1BR06CL01	1B	1,400	0,050	9,00	6	—	—	0,15	●	●	○	○	○	○	○
EC020M02L06CL02	2	2,000	0,050	8,96	—	6	0,20	—	●	●	○	○	○	○	○
EC020M02N00CL02	2	2,000	0,050	8,97	—	—	0,20	0,20	●	●	○	○	○	○	○
EC020M02R06CL02	2	2,000	0,050	8,96	6	—	—	0,20	●	●	○	○	○	○	○
EC030M03L06CL02	3	3,000	0,075	9,59	—	6	0,20	—	●	●	○	○	○	○	○
EC030M03N00CL02	3	3,000	0,075	9,60	—	—	0,20	0,20	●	●	○	○	○	○	○
EC030M03R06CL02	3	3,000	0,075	9,59	6	—	—	0,20	●	●	○	○	○	○	○
EC040M04L06CL02	4	4,000	0,075	10,19	—	6	0,20	—	●	●	○	○	○	○	○
EC040M04N00CL02	4	4,000	0,075	10,20	—	—	0,20	0,20	●	●	○	○	○	○	○
EC040M04R06CL02	4	4,000	0,075	10,19	6	—	—	0,20	●	●	○	○	○	○	○

P	●	●	●	○	○	○	○	○	○	○	○	○	○	○	○
M	●	●	○	○	○	○	○	○	○	○	○	○	○	○	○
K	○	○	○	○	○	○	○	○	○	○	○	○	○	○	○
N	●	○	○	○	○	○	○	○	○	○	○	○	○	○	○
S	●	●	○	○	○	○	○	○	○	○	○	○	○	○	○
H	○	○	○	○	○	○	○	○	○	○	○	○	○	○	○

- Ultimate solution in edge stability.
- Leverage for interrupted cuts or hardened skin.
- First choice for cast iron.

● first choice  
○ alternate choice

P	●	●	●	○				
M	●	●			●	○		
K	○	○	○	○	●	○		
N	●	○					●	
S	●	●					●	
H	○							

Grooving and Cut-Off

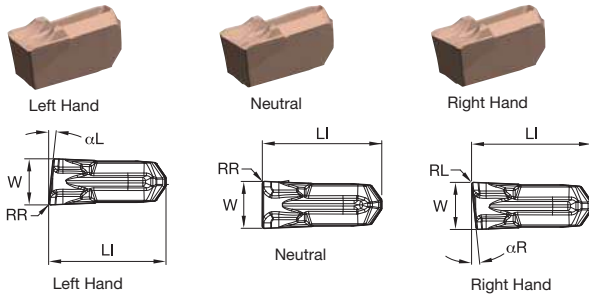

**CM Precision Moulded • Metric**

catalogue number	seat size	W	W tol ±	LI	αR	αL	RR	RL	KCU10	KCU25	KCP10B	KCP25B	KCK20B	KCM35B	K313
EC014M1BL06CM01	1B	1,400	0,050	9,00	—	6	0,20	—	-	●	-	-	-	-	-
EC014M1BN00CM01	1B	1,400	0,050	9,00	—	—	0,15	0,15	-	●	-	-	-	-	-
EC014M1BR06CM01	1B	1,400	0,050	9,00	6	—	—	0,20	-	●	-	-	-	-	-
EC020M02L06CM02	2	2,000	0,050	9,00	—	6	0,20	—	-	●	-	-	-	-	-
EC020M02N00CM02	2	2,000	0,050	8,98	—	—	0,20	0,20	-	●	-	-	-	-	-
EC020M02R06CM02	2	2,000	0,050	9,00	6	—	—	0,20	-	●	-	-	-	-	-
EC030M03L06CM02	3	3,000	0,075	9,60	—	6	0,20	—	-	●	-	-	-	-	-
EC030M03N00CM02	3	3,000	0,075	9,60	—	—	0,20	0,20	-	●	-	-	-	-	-
EC030M03R06CM02	3	3,000	0,075	9,60	6	—	—	0,20	-	●	-	-	-	-	-
EC040M04L06CM02	4	4,000	0,075	10,20	—	6	0,20	—	-	●	-	-	-	-	-
EC040M04N00CM02	4	4,000	0,075	10,20	—	—	0,20	0,20	-	●	-	-	-	-	-
EC040M04R06CM02	4	4,000	0,075	10,20	6	—	—	0,20	-	●	-	-	-	-	-
EC050M05N00CM03	5	5,000	0,075	12,20	—	—	0,30	0,30	-	●	-	-	-	-	-
EC060M06N00CM03	6	6,000	0,075	14,59	—	—	0,30	0,30	-	●	-	-	-	-	-
EC070M06N00CM04	6	7,000	0,075	14,60	—	—	0,40	0,40	-	●	-	-	-	-	-
EC080M08N00CM04	8	8,000	0,075	17,50	—	—	0,40	0,40	-	●	-	-	-	-	-

- Strong chip control due to concave edge.
- First choice in steel when additional stability is required.
- Can apply most aggressive speed rates.

● first choice  
○ alternate choice

P	●	●	●	○																	
M	●	●	○	○	○																
K	○	○	○	○	○	○	○	○	○	○	○	○	○	○	○	○	○	○	○	○	○
N	●	○																			
S	●	●																			
H	○																				

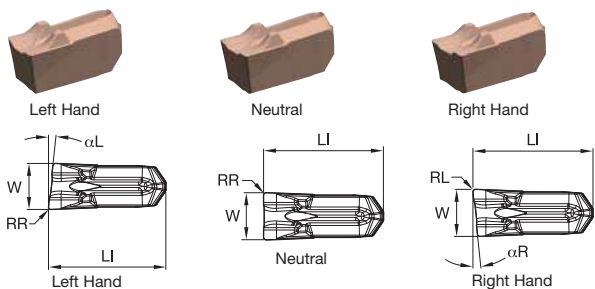

### CR Precision Moulded • Metric

catalogue number	seat size	W	W tol ±	LI	αR	αL	RR	RL	KCU10	KCU25	KCP10B	KCP25B	KCK20B	KCM35B	K313
EC020M02L06CR02	2	2,000	0,050	9,00	—	6	0,20	—	—	●	—	—	—	—	—
EC020M02N00CR02	2	2,000	0,050	8,98	—	—	0,20	0,20	—	●	—	—	—	—	—
EC020M02R06CR02	2	2,000	0,050	9,00	6	—	—	0,20	—	●	—	—	—	—	—
EC030M03L06CR02	3	3,000	0,075	9,60	—	6	0,20	—	—	●	—	—	—	—	—
EC030M03N00CR02	3	3,000	0,075	9,60	—	—	0,20	0,20	—	●	—	—	—	—	—
EC030M03R06CR02	3	3,000	0,075	9,60	6	—	—	0,20	—	●	—	—	—	—	—
EC040M04L06CR02	4	4,000	0,075	10,20	—	6	0,20	—	—	●	—	—	—	—	—
EC040M04N00CR02	4	4,000	0,075	10,20	—	—	0,20	0,20	—	●	—	—	—	—	—
EC040M04R06CR02	4	4,000	0,075	10,20	6	—	—	0,20	—	●	—	—	—	—	—
EC050M05N00CR03	5	5,000	0,075	12,25	—	—	0,30	0,30	—	●	—	—	—	—	—
EC060M06L06CR04	6	6,000	0,075	14,59	—	6	0,40	—	—	●	—	—	—	—	—
EC060M06N00CR03	6	6,000	0,075	14,59	—	—	0,30	0,30	—	●	—	—	—	—	—
EC060M06R06CR04	6	6,000	0,075	14,59	6	—	—	0,40	—	●	—	—	—	—	—
EC070M06N00CR04	6	7,000	0,075	14,60	—	—	0,40	0,40	—	●	—	—	—	—	—
EC080M08L06CR04	8	8,000	0,075	17,50	—	6	0,40	—	—	●	—	—	—	—	—
EC080M08N00CR04	8	8,000	0,075	17,50	—	—	0,40	0,40	—	●	—	—	—	—	—
EC080M08R06CR04	8	8,000	0,075	17,50	6	—	—	0,40	—	●	—	—	—	—	—

Grooving and Cut-Off

## How Do Catalogue Numbers Work?

Each character in our catalogue number signifies a specific trait of that product. Use the following key columns and corresponding images to easily identify which attributes apply.



**EVSM1603035C**

<b>EV</b>	<b>S</b>	<b>M</b>	<b>L</b>	<b>2525M</b>	<b>03</b>	<b>16</b>	<b>030035</b>	<b>C</b>
Family Name	Tool Style	Support Type	Hand	Shank Size	Seat Size	Max Groove Depth	Face Grooving Diameters	Coolant
Beyond™ Evolution™	<b>S</b> = Straight mount		<b>L</b> = Left hand  <b>R</b> = Right hand		<b>1B</b> <b>1F</b> <b>02</b> <b>03</b> <b>04</b> <b>05</b> <b>06</b> <b>08</b> <b>10</b>	in millimetres	<b>030</b> = Minimum diameter in mm  <b>035</b> = Maximum diameter in mm	<b>C</b> = Through the pocket coolant capable

**M** = Maximum support for specific groove width and straight clearance for unlimited workpiece diameter

**A** = Face grooving — inboard sweep

**B** = Face grooving — outboard sweep

**Metric** = Height x Width in mm letter indicates tool length according to ISO

By referencing this easy-to-use guide, you can identify the correct product to meet your needs.



**EVSCTL2525M0316C**

<b>EV</b>	<b>S</b>	<b>C</b>	<b>T</b>	<b>L</b>	<b>2525M</b>	<b>03</b>	<b>16</b>	<b>C</b>
Family Name	Tool Style	Support Type	Clamping Screw Position	Hand	Shank Size	Seat Size	Max Groove Depth	Coolant
Beyond™ Evolution™	S = Straight mount		T = Top  F = Front	L = Left hand  R = Right hand		1B 1F 02 03 04 05 06 08 10	in millimetres	C = Through the pocket coolant capable
C = Reinforced support			Metric = Height x Width in mm letter indicates tool length according to ISO					

## How Do Catalogue Numbers Work?

Each character in our catalogue number signifies a specific trait of that product. Use the following key columns and corresponding images to easily identify which attributes apply.

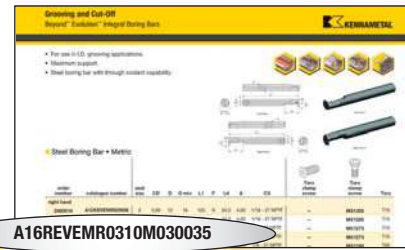

**A16REVEMR0310M030035**

<b>A</b>	<b>16</b>	<b>R</b>	<b>EV</b>	<b>E</b>	<b>M</b>	<b>R</b>	<b>03</b>	<b>10</b>	<b>M</b>	<b>030035</b>																							
Steel Bar with Coolant	Bar Diameter	Bar Length	Platform	Tool Type	Support Type	Hand of Tool	Insert Seat Size	Max Cutting Depth	Tool Units	Face Grooving Diameters																							
Steel boring bar with through coolant capability.			Beyond™ Evolution™	<b>E</b> = End mount (90°) <b>S</b> = Straight Mount	<b>M</b> = Maximum support <b>A</b> = Face Grooving-inboard sweep	<b>R</b> = Right hand <b>L</b> = Left hand	<b>1F</b> <b>02</b> <b>03</b> <b>04</b> <b>05</b> <b>06</b> <b>08</b> <b>10</b>	in millimetres	<b>M</b> = Metric <b>I</b> = Inch	<b>030</b> = Minimum diameter in mm <b>035</b> = Maximum diameter in mm																							
<b>Metric</b> = Diameter in mm  <b>Inch</b> = Diameter in 1/16" increments		<table border="1"> <thead> <tr> <th>symbol</th> <th>mm</th> <th>inch</th> </tr> </thead> <tbody> <tr> <td>K</td> <td>125</td> <td>5</td> </tr> <tr> <td>M</td> <td>150</td> <td>6</td> </tr> <tr> <td>Q</td> <td>180</td> <td>7</td> </tr> <tr> <td>R</td> <td>200</td> <td>8</td> </tr> <tr> <td>S</td> <td>250</td> <td>10</td> </tr> <tr> <td>T</td> <td>300</td> <td>12</td> </tr> </tbody> </table>			symbol	mm	inch	K	125	5	M	150	6	Q	180	7	R	200	8	S	250	10	T	300	12								
symbol	mm	inch																															
K	125	5																															
M	150	6																															
Q	180	7																															
R	200	8																															
S	250	10																															
T	300	12																															



**EVBSL32J0320**

<b>EV</b>	<b>B</b>	<b>S</b>	<b>L</b>	<b>32</b>	<b>J</b>	<b>03</b>	<b>20</b>
Family Name	Tool Style	Support Type	Hand	Blade Height	Overall Length	Seat Size	Max Cutting Depth
Beyond™ Evolution™	<b>B</b> = 2 pocket blade	<b>S</b> = Standard <b>C</b> = Reinforced	<b>N</b> = Neutral <b>L</b> = Left hand <b>R</b> = Right hand	in millimetres	According to ISO <b>G</b> = 90mm <b>J</b> = 110mm <b>M</b> = 150mm <b>X</b> = Special	<b>1B</b> <b>1F</b> <b>02</b> <b>03</b> <b>04</b> <b>05</b> <b>06</b> <b>08</b> <b>10</b>	in millimetres

By referencing this easy-to-use guide, you can identify the correct product to meet your needs



KGMSL2525M50C

<b>KGM</b>	<b>S</b>	<b>L</b>	<b>2525M</b>	<b>50</b>	<b>C</b>
Family Name	Tool Style	Hand	Shank Size	Blade Size	Coolant
Grooving Modular System	S = Straight mount E = End mount (90°)	L = Left hand R = Right hand	<b>Metric</b> = Height x Width in mm letter indicates tool length according to ISO	50 65	C = Through coolant capable

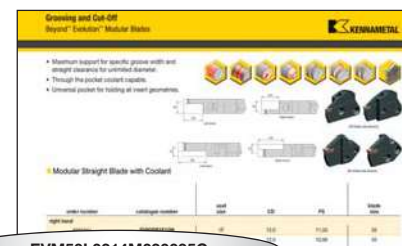

EVM50L0314M030035C

<b>EVM</b>	<b>50</b>	<b>L</b>	<b>03</b>	<b>14</b>	<b>M</b>	<b>030035</b>	<b>C</b>
Family Name	Blade Size	Hand	Seat Size	Max Groove Depth	Support Type	Face Grooving Diameters	Coolant
Beyond™ Evolution™ Modular Blade	50 65	L = Left hand R = Right hand	1B 1F 02 03 04 05 06 08 10	in millimetres	M = Maximum support for specific groove width and straight clearance for unlimited diameter A = Face grooving-inboard sweep B = Face grooving-outboard sweep	030 = Minimum diameter in mm 035 = Maximum diameter in mm	C = Through the pocket coolant capable



## How Do Catalogue Numbers Work?

Each character in our catalogue number signifies a specific trait of that product. Use the following key columns and corresponding images to easily identify which attributes apply.

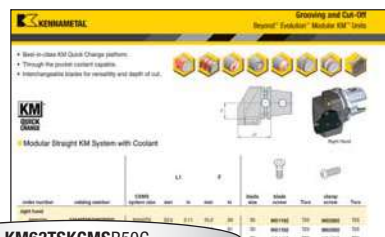

**KM63TSKGMRS50C**

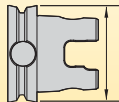
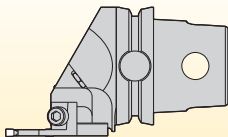
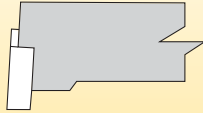
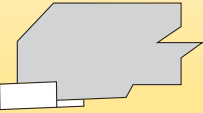
<p><b>KM</b></p>	<p><b>63</b></p>	<p><b>TS</b></p>	<p><b>KGM</b></p>	<p><b>S</b></p>
<p>KM™ Quick-Change</p>	<p>System Size</p>	<p>Feature</p>	<p>Insert Holding Method</p>	<p>Insert Location</p>
<p><b>KM</b> <b>KM4X™</b> <b>PSC</b></p>	<p>40 = 40mm 50 = 50mm 63 = 63mm 80 = 80mm 100 = 100mm</p> 	<p><b>TS</b> <b>XMZ</b></p>	<p><b>KGM</b></p>  <p><b>Modular Grooving</b></p>	<p><b>E</b> = End mount <b>S</b> = Side mount</p>  

By referencing this easy-to-use guide, you can identify the correct product to meet your needs.

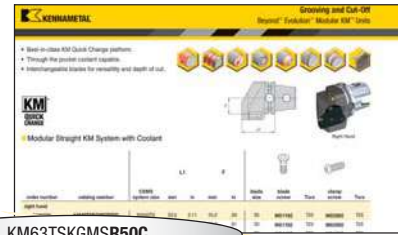

KM63TSKGMRS50C

**R**

Hand of Tool

R = Right hand

L = Left hand

End Mount

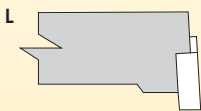
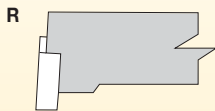

Side Mount

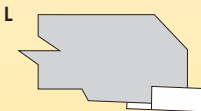
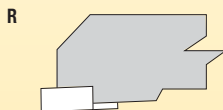

**50**

Blade Size

50

60

**C**

Coolant

C = Through the pocket coolant capable

Special Features

Y = Mazak®  
 INTEGREX®

## How Do Catalogue Numbers Work?

Each character in our catalogue number signifies a specific trait of that product. Use the following key columns and corresponding images to easily identify which attributes apply.

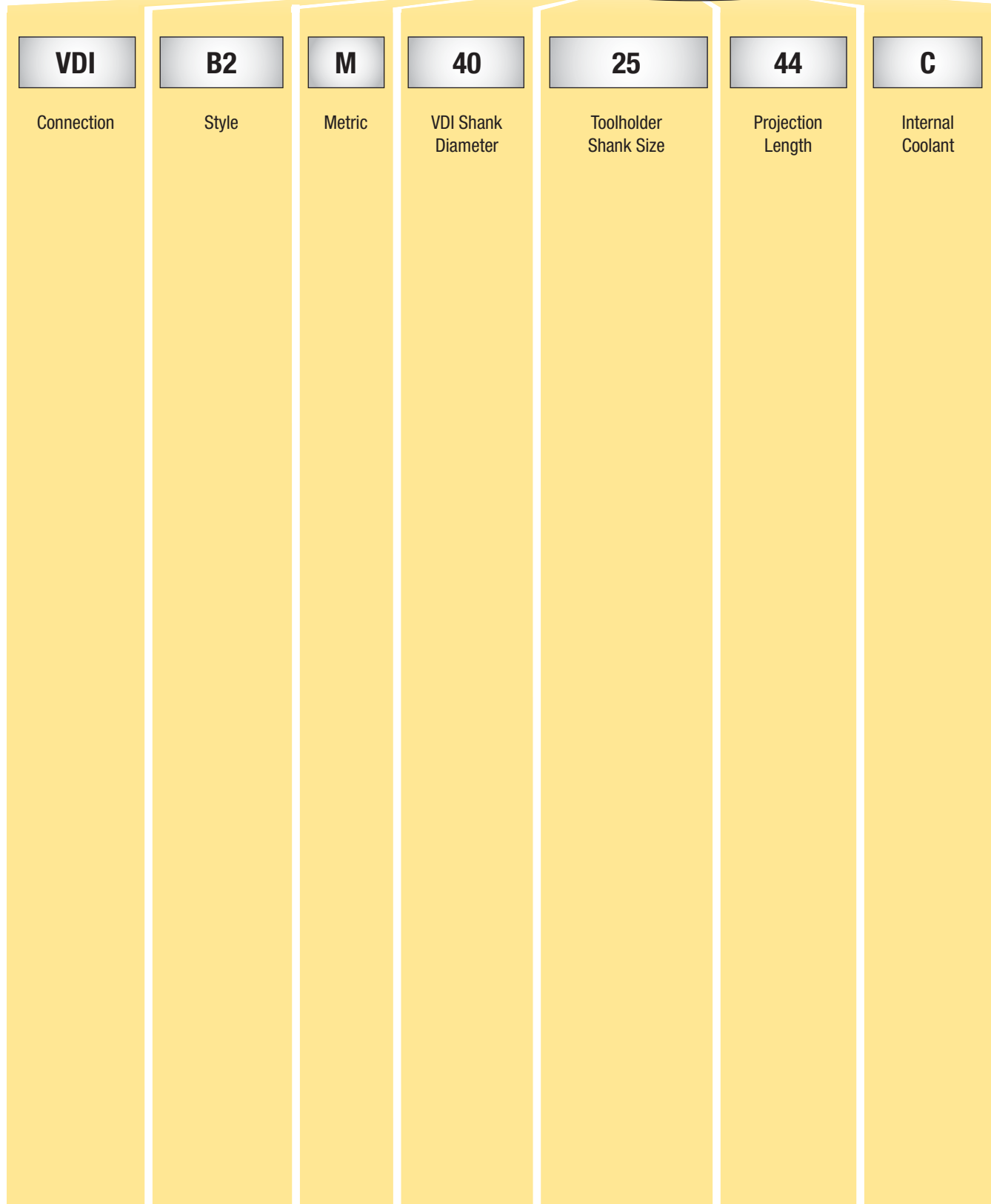

## NOVO KNOWS SEARCH

Searching for a tool has been enhanced by Advise and Select functions from NOVO™ applications — saving you time and money.

---

### ADVISE

Uses a rules-based approach to provide cutting tool recommendations:

- Define Machining Feature (face milling, slotting, blind hole, etc.)
- Apply Constraint Requirements (geometric, material, tolerance, etc.)
- Set Machining Sequence (single or multi-step operations, rough then finish, etc.)
- Receive Ranked Results

---

### SELECT

A method of selecting cutting tools from a tree structure via a hierarchy or parametric search:

- If you know which product you are looking for, a quick search can be performed by just the catalogue number or product description.
- Smart filters significantly reduce the amount of potential tooling solutions.
- After the tool is selected, NOVO also provides cutting and adaptive item options that fit with your solution.

NOVO applications can ensure you have the right tools on your machines, in the right sequence. Resulting in flawless execution that accelerates every job, and maximises every shift. [kennametal.com/novo](http://kennametal.com/novo)

- Offers the greatest stability.
- Straight clearance for unlimited workpiece diameters.
- Through the pocket coolant capable.

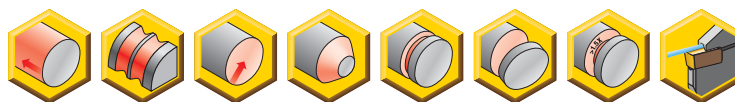

Grooving and Cut-Off

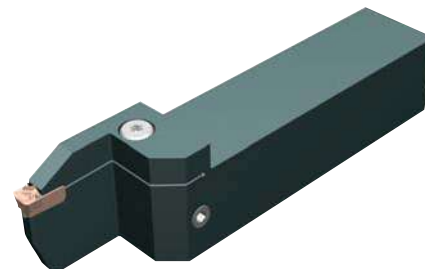
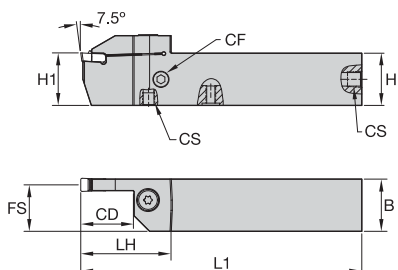

Left Hand

■ Integral Straight • Metric

order number	catalogue number	seat size	CD	H1	H	B	H2	L1	FS	LH	CF	CS	Torx clamp screw	Torx clamp screw	Torx
<b>right hand</b>															
5953960	EVSMR2020K0216	2	16	20	20	20	27	125	19	31	—	—	—	MS1160	T20
5953958	EVSMR2525M0216	2	16	25	25	25	32	150	24	31	—	—	—	MS1160	T20
6401854	EVSMR2020K0216C	2	16	20	20	20	28	125	19	35	M8X1	M8X1	MS2091	—	25 IP
6401855	EVSMR2525M0216C	2	16	25	25	25	33	150	24	35	G1/8 - 28	G1/8 - 28	MS2091	—	25 IP
5953959	EVSMR2020K0222	2	22	20	20	20	29	125	19	38	—	—	MS2091	—	25 IP
6401857	EVSMR2020K0222C	2	22	20	20	20	29	125	19	41	M8X1	M8X1	MS2091	—	25 IP
5953957	EVSMR2525M0226	2	26	25	25	25	34	150	24	42	—	—	MS2091	—	25 IP
6401856	EVSMR2525M0226C	2	26	25	25	25	34	150	24	45	G1/8 - 28	G1/8 - 28	MS2091	—	25 IP
5939452	EVSMR2020K0316C	3	16	20	20	20	29	125	19	37	1/16 - 27 NPTF	1/16 - 27 NPTF	MS1595	—	T30
5939448	EVSMR2525M0316C	3	16	25	25	25	34	150	24	37	1/8 - 27 NPTF	1/8 - 27 NPTF	MS1595	—	T30
5939451	EVSMR2020K0322C	3	22	20	20	20	29	125	19	43	1/16 - 27 NPTF	1/16 - 27 NPTF	MS1595	—	T30
5939447	EVSMR2525M0326C	3	26	25	25	25	34	150	24	47	1/8 - 27 NPTF	1/8 - 27 NPTF	MS1595	—	T30
5939450	EVSMR2020K0416C	4	16	20	20	20	29	125	18	37	1/16 - 27 NPTF	1/16 - 27 NPTF	MS1595	—	T30
5939446	EVSMR2525M0416C	4	16	25	25	25	34	150	23	37	1/8 - 27 NPTF	1/8 - 27 NPTF	MS1595	—	T30
5939449	EVSMR2020K0422C	4	22	20	20	20	29	125	18	43	1/16 - 27 NPTF	1/16 - 27 NPTF	MS1595	—	T30
5939445	EVSMR2525M0426C	4	26	25	25	25	34	150	23	47	1/8 - 27 NPTF	1/8 - 27 NPTF	MS1595	—	T30
5939444	EVSMR3232P0426C	4	26	32	32	32	42	170	30	47	1/8 - 27 NPTF	1/8 - 27 NPTF	MS1970	—	T30
5939443	EVSMR3232P0432C	4	32	32	32	32	42	170	30	53	1/8 - 27 NPTF	1/8 - 27 NPTF	MS1970	—	T30
5954258	EVSMR2020K0516C	5	16	20	20	20	29	125	18	37	1/16 - 27 NPTF	1/16 - 27 NPTF	MS1595	—	T30
5954254	EVSMR2525M0516C	5	16	25	25	25	34	150	23	37	1/8 - 27 NPTF	1/8 - 27 NPTF	MS1970	—	T30
5954257	EVSMR2020K0522C	5	22	20	20	20	29	125	18	43	1/16 - 27 NPTF	1/16 - 27 NPTF	MS1595	—	T30
5954253	EVSMR2525M0526C	5	26	25	25	25	34	150	23	47	1/8 - 27 NPTF	1/8 - 27 NPTF	MS1970	—	T30
5954249	EVSMR3232P0526C	5	26	32	32	32	42	170	30	47	1/8 - 27 NPTF	1/8 - 27 NPTF	MS1970	—	T30

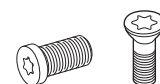

(continued)

(Integral Straight • Metric — continued)

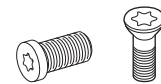

order number	catalogue number	seat size	CD	H1	H	B	H2	L1	FS	LH	CF	CS	Torx clamp screw	Torx clamp screw	Torx
5954248	EVSMR3232P0532C	5	32	32	32	32	42	170	30	53	1/8 - 27 NPTF	1/8 - 27 NPTF	MS1970	—	T30
5954256	EVSMR2020K0616C	6	16	20	20	20	29	125	20	37	1/16 - 27 NPTF	1/16 - 27 NPTF	MS1595	—	T30
5954252	EVSMR2525M0616C	6	16	25	25	25	34	150	25	37	1/8 - 27 NPTF	1/8 - 27 NPTF	MS1970	—	T30
5954255	EVSMR2020K0622C	6	22	20	20	20	29	125	20	43	1/16 - 27 NPTF	1/16 - 27 NPTF	MS1595	—	T30
5954251	EVSMR2525M0626C	6	26	25	25	25	34	150	25	47	1/8 - 27 NPTF	1/8 - 27 NPTF	MS1970	—	T30
5954247	EVSMR3232P0626C	6	26	32	32	32	42	170	32	47	1/8 - 27 NPTF	1/8 - 27 NPTF	MS1970	—	T30
5954246	EVSMR3232P0632C	6	32	32	32	32	43	170	29	55	1/8 - 27 NPTF	1/8 - 27 NPTF	MS1490	—	T45
5954242	EVSMR4040R0640C	6	40	40	40	40	51	200	37	63	1/8 - 27 NPTF	1/8 - 27 NPTF	MS1490	—	T45
5954250	EVSMR2525M0826C	8	26	25	25	25	35	150	21	49	1/8 - 27 NPTF	1/8 - 27 NPTF	MS1490	—	T45
5954245	EVSMR3232P0826C	8	26	32	32	32	43	170	28	49	1/8 - 27 NPTF	1/8 - 27 NPTF	MS1490	—	T45
5954244	EVSMR3232P0832C	8	32	32	32	32	43	170	28	55	1/8 - 27 NPTF	1/8 - 27 NPTF	MS1490	—	T45
5954241	EVSMR4040R0840C	8	40	40	40	40	51	200	36	63	1/8 - 27 NPTF	1/8 - 27 NPTF	MS1490	—	T45
5954243	EVSMR3232P1032C	10	32	32	32	32	43	170	28	55	1/8 - 27 NPTF	1/8 - 27 NPTF	MS1490	—	T45
5954240	EVSMR4040R1040C	10	40	40	40	40	51	200	36	63	1/8 - 27 NPTF	1/8 - 27 NPTF	MS1490	—	T45
left hand															
5953956	EVSMML2020K0216	2	16	20	20	20	27	125	19	31	—	—	—	MS1160	T20
5953954	EVSMML2525M0216	2	16	25	25	25	32	150	24	31	—	—	—	MS1160	T20
6401881	EVSMML2525M0216C	2	16	25	25	25	33	150	24	35	G1/8 - 28	G1/8 - 28	MS2091	—	25 IP
5953955	EVSMML2020K0222	2	22	20	20	20	29	125	19	38	—	—	MS2091	—	25 IP
5953953	EVSMML2525M0226	2	26	25	25	25	34	150	24	42	—	—	MS2091	—	25 IP
5939442	EVSMML2020K0316C	3	16	20	20	20	29	125	19	37	1/16 - 27 NPTF	1/16 - 27 NPTF	MS1595	—	T30
5939438	EVSMML2525M0316C	3	16	25	25	25	34	150	24	37	1/8 - 27 NPTF	1/8 - 27 NPTF	MS1595	—	T30
5939441	EVSMML2020K0322C	3	22	20	20	20	29	125	19	43	1/16 - 27 NPTF	1/16 - 27 NPTF	MS1595	—	T30
5939437	EVSMML2525M0326C	3	26	25	25	25	34	150	24	47	1/8 - 27 NPTF	1/8 - 27 NPTF	MS1595	—	T30
5939440	EVSMML2020K0416C	4	16	20	20	20	29	125	18	37	1/16 - 27 NPTF	1/16 - 27 NPTF	MS1595	—	T30
5939436	EVSMML2525M0416C	4	16	25	25	25	34	150	23	37	1/8 - 27 NPTF	1/8 - 27 NPTF	MS1595	—	T30
5939439	EVSMML2020K0422C	4	22	20	20	20	29	125	18	43	1/16 - 27 NPTF	1/16 - 27 NPTF	MS1595	—	T30
5939435	EVSMML2525M0426C	4	26	25	25	25	34	150	23	47	1/8 - 27 NPTF	1/8 - 27 NPTF	MS1595	—	T30
5939433	EVSMML3232P0426C	4	26	32	32	32	42	170	30	47	1/8 - 27 NPTF	1/8 - 27 NPTF	MS1970	—	T30
5939432	EVSMML3232P0432C	4	32	32	32	32	42	170	30	53	1/8 - 27 NPTF	1/8 - 27 NPTF	MS1970	—	T30
5954239	EVSMML2020K0516C	5	16	20	20	20	29	125	18	37	1/16 - 27 NPTF	1/16 - 27 NPTF	MS1595	—	T30
5954235	EVSMML2525M0516C	5	16	25	25	25	34	150	23	37	1/8 - 27 NPTF	1/8 - 27 NPTF	MS1970	—	T30
5954238	EVSMML2020K0522C	5	22	20	20	20	29	125	18	43	1/16 - 27 NPTF	1/16 - 27 NPTF	MS1595	—	T30
5954234	EVSMML2525M0526C	5	26	25	25	25	34	150	23	47	1/8 - 27 NPTF	1/8 - 27 NPTF	MS1970	—	T30
5954220	EVSMML3232P0526C	5	26	32	32	32	42	170	30	47	1/8 - 27 NPTF	1/8 - 27 NPTF	MS1970	—	T30
5954219	EVSMML3232P0532C	5	32	32	32	32	42	170	30	53	1/8 - 27 NPTF	1/8 - 27 NPTF	MS1970	—	T30
5954237	EVSMML2020K0616C	6	16	20	20	20	29	125	17	37	1/16 - 27 NPTF	1/16 - 27 NPTF	MS1595	—	T30
5954233	EVSMML2525M0616C	6	16	25	25	25	34	150	22	37	1/8 - 27 NPTF	1/8 - 27 NPTF	MS1970	—	T30
5954236	EVSMML2020K0622C	6	22	20	20	20	29	125	17	43	1/16 - 27 NPTF	1/16 - 27 NPTF	MS1595	—	T30
5954232	EVSMML2525M0626C	6	26	25	25	25	34	150	22	47	1/8 - 27 NPTF	1/8 - 27 NPTF	MS1970	—	T30

(continued)

(Integral Straight • Metric — continued)

Grooving and Cut-Off

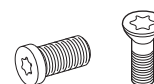

order number	catalogue number	seat size	CD	H1	H	B	H2	L1	FS	LH	CF	CS	Torx clamp screw	Torx clamp screw	Torx
													MS1970	MS1490	T30
5954218	EVSML3232P0626C	6	26	32	32	32	42	170	29	47	1/8 - 27 NPTF	1/8 - 27 NPTF	MS1970	—	T30
5954217	EVSML3232P0632C	6	32	32	32	32	43	170	29	55	1/8 - 27 NPTF	1/8 - 27 NPTF	MS1490	—	T45
5954213	EVSML4040R0640C	6	40	40	40	40	51	200	37	63	1/8 - 27 NPTF	1/8 - 27 NPTF	MS1490	—	T45
5954231	EVSML2525M0826C	8	26	25	25	25	35	150	21	49	1/8 - 27 NPTF	1/8 - 27 NPTF	MS1490	—	T45
5954216	EVSML3232P0826C	8	26	32	32	32	43	170	28	49	1/8 - 27 NPTF	1/8 - 27 NPTF	MS1490	—	T45
5954215	EVSML3232P0832C	8	32	32	32	32	43	170	28	55	1/8 - 27 NPTF	1/8 - 27 NPTF	MS1490	—	T45
5954212	EVSML4040R0840C	8	40	40	40	40	51	200	36	63	1/8 - 27 NPTF	1/8 - 27 NPTF	MS1490	—	T45
5954214	EVSML3232P1032C	10	32	32	32	32	43	170	28	55	1/8 - 27 NPTF	1/8 - 27 NPTF	MS1490	—	T45
5954211	EVSML4040R1040C	10	40	40	40	40	51	200	36	63	1/8 - 27 NPTF	1/8 - 27 NPTF	MS1490	—	T45

screw catalogue number	screw order number	torque		thread	socket	wrench catalogue number	wrench order number
		Nm	in. lbs.				
MS1160	1099645	7	62	M5	T20	KT20	1022703
MS1162	1127019	9	80	M6	T25	KT25	1022725
MS1163	1124104	18	159	M8	T30	KT30L	1099676
MS1273	1020977	4	35.4	M4	T15	KT15	1022701
MS1490	2263299	17	151	M8	T45	KT45	1018227
MS1595	1094300	12	106	M6	T30	KT30	1099676
MS1970	1106668	12	106	M6	T30	KT30	1099676
MS2002	1621087	9	80	M6	T25	KT25	1022725
MS2091	1931147	9	80	M5	25IP	K25IP	2050113

- Through the pocket coolant capable.
- Reinforced for added support in specific workpiece diameters.

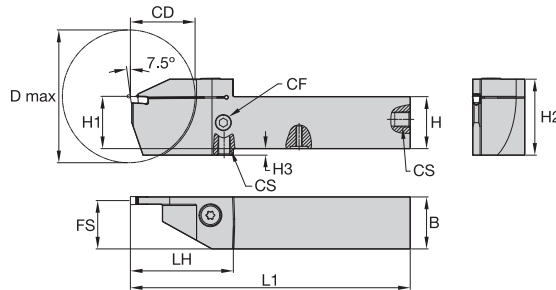

CD = Maximum cut-off depth for solid bars.  
D max = Maximum bar diameter for deep grooving or cut-off of tubes.

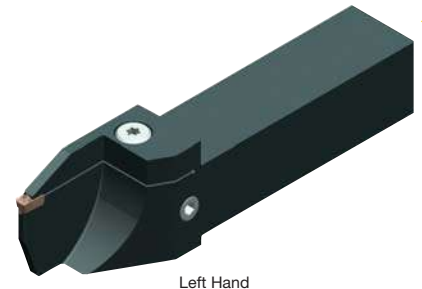

Grooving and Cut-Off

■ Integral Straight Top Clamp • Metric

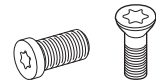

order number	catalogue number	seat size	CD	D max	H1	H	B	H2	H3	L1	FS	LH	CF	CS	Torx clamp screw	Torx clamp screw Torx
<b>right hand</b>																
6179757	EVSCTR1212K1B16	1B	16	42	12	12	12	23	4	125	11	31	—	—	—	MS1160 T20
6179758	EVSCTR1212K1F16	1F	16	42	12	12	12	23	4	125	11	31	—	—	—	MS1160 T20
6179759	EVSCTR1212K0216	2	16	42	12	12	12	23	4	125	11	31	—	—	—	MS1160 T20
5980139	EVSCTR1616K0216	2	16	42	16	16	16	23	—	125	15	31	—	—	—	MS1160 T20
5980762	EVSCTR2020K0216	2	16	42	20	20	20	27	—	125	19	31	—	—	—	MS1160 T20
5980767	EVSCTR2525M0216	2	16	42	25	25	25	32	—	150	24	31	—	—	—	MS1160 T20
5980768	EVSCTR2525M0226	2	26	62	25	25	25	34	—	150	24	42	—	—	MS2091	— 25 IP
6179755	EVSCTR1212K0316C	3	16	52	12	12	12	23	4	125	11	34	M8X1.25	M8X1.25	MS1944	— T25
5980140	EVSCTR1616K0316C	3	16	52	16	16	16	24	—	125	15	36	1/16 - 27 NPTF	1/16 - 27 NPTF	MS2091	— 25 IP
5980763	EVSCTR2020K0316C	3	16	52	20	20	20	29	—	125	19	37	1/16 - 27 NPTF	1/16 - 27 NPTF	MS1595	— T30
5980138	EVSCTR2525M0316C	3	16	62	25	25	25	34	—	150	24	37	1/8 - 27 NPTF	1/8 - 27 NPTF	MS1595	— T30
5980764	EVSCTR2020K0326C	3	26	62	20	20	20	33	4	125	19	47	1/16 - 27 NPTF	1/16 - 27 NPTF	MS1595	— T30
5980769	EVSCTR2525M0326C	3	26	62	25	25	25	34	—	150	24	47	1/8 - 27 NPTF	1/8 - 27 NPTF	MS1595	— T30
5980761	EVSCTR1616K0416C	4	16	52	16	16	16	24	—	125	14	36	1/16 - 27 NPTF	1/16 - 27 NPTF	MS2091	— 25 IP
5980765	EVSCTR2020K0416C	4	16	52	20	20	20	29	—	125	18	37	1/16 - 27 NPTF	1/16 - 27 NPTF	MS1595	— T30
5980766	EVSCTR2020K0426C	4	26	62	20	20	20	33	—	125	18	47	1/16 - 27 NPTF	1/16 - 27 NPTF	MS1595	— T30
5980770	EVSCTR2525M0426C	4	26	62	25	25	25	34	—	150	23	47	1/8 - 27 NPTF	1/8 - 27 NPTF	MS1595	— T30
5980771	EVSCTR2525M0432C	4	32	64	25	25	25	38	4	150	23	53	1/8 - 27 NPTF	1/8 - 27 NPTF	MS1595	— T30
5980774	EVSCTR3232P0432C	4	32	64	32	32	32	42	—	170	30	53	1/8 - 27 NPTF	1/8 - 27 NPTF	MS1970	— T30
5980772	EVSCTR2525M0526C	5	26	62	25	25	25	34	—	150	23	47	1/8 - 27 NPTF	1/8 - 27 NPTF	MS1970	— T30
5980773	EVSCTR2525M0532C	5	32	64	25	25	25	39	4	150	23	53	1/8 - 27 NPTF	1/8 - 27 NPTF	MS1970	— T30
5980775	EVSCTR3232P0540C	5	40	82	32	32	32	47	4	170	30	63	1/8 - 27 NPTF	1/8 - 27 NPTF	MS1490	— T45

(continued)



(Integral Straight Top Clamp • Metric — continued)

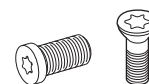

Grooving and Cut-Off

order number	catalogue number	seat size	CD	D max	H1	H	B	H2	H3	L1	FS	LH	CF	CS	Torx clamp screw	Torx clamp screw	Torx
															MS1160	MS1160	T20
left hand																	
6179760	EVSCTL1212K1B16	1B	16	42	12	12	12	23	4	125	11	31	—	—	—	MS1160	T20
6179761	EVSCTL1212K1F16	1F	16	42	12	12	12	23	4	125	11	31	—	—	—	MS1160	T20
6179762	EVSCTL1212K0216	2	16	42	12	12	12	23	4	125	11	31	—	—	—	MS1160	T20
5980777	EVSCTL1616K0216	2	16	42	16	16	16	23	—	125	15	31	—	—	—	MS1160	T20
5980780	EVSCTL2020K0216	2	16	42	20	20	20	27	—	125	19	31	—	—	—	MS1160	T20
5980805	EVSCTL2525M0216	2	16	42	25	25	25	32	—	150	24	31	—	—	—	MS1160	T20
5980806	EVSCTL2525M0226	2	26	62	25	25	25	34	—	150	24	42	—	—	MS2091	—	25 IP
6179756	EVSCTL1212K0316C	3	16	52	12	12	12	23	4	125	11	34	M8X1.25	M8X1.25	MS1944	—	T25
5980778	EVSCTL1616K0316C	3	16	52	16	16	16	24	—	125	15	36	1/16 - 27 NPTF	1/16 - 27 NPTF	MS2091	—	25 IP
5980801	EVSCTL2020K0316C	3	16	52	20	20	20	29	—	125	19	37	1/16 - 27 NPTF	1/16 - 27 NPTF	MS1595	—	T30
5980776	EVSCTL2525M0316C	3	16	62	25	25	25	34	—	150	24	37	1/8 - 27 NPTF	1/8 - 27 NPTF	MS1595	—	T30
5980802	EVSCTL2020K0326C	3	26	62	20	20	20	33	4	125	19	47	1/16 - 27 NPTF	1/16 - 27 NPTF	MS1595	—	T30
5980807	EVSCTL2525M0326C	3	26	62	25	25	25	34	—	150	24	47	1/8 - 27 NPTF	1/8 - 27 NPTF	MS1595	—	T30
5980779	EVSCTL1616K0416C	4	16	52	16	16	16	24	—	125	14	36	1/16 - 27 NPTF	1/16 - 27 NPTF	MS2091	—	25 IP
5980803	EVSCTL2020K0416C	4	16	52	20	20	20	29	—	125	18	37	1/16 - 27 NPTF	1/16 - 27 NPTF	MS1595	—	T30
5980804	EVSCTL2020K0426C	4	26	62	20	20	20	33	—	125	18	47	1/16 - 27 NPTF	1/16 - 27 NPTF	MS1595	—	T30
5980808	EVSCTL2525M0426C	4	26	62	25	25	25	34	—	150	23	47	1/8 - 27 NPTF	1/8 - 27 NPTF	MS1595	—	T30
5980809	EVSCTL2525M0432C	4	32	64	25	25	25	38	4	150	23	53	1/8 - 27 NPTF	1/8 - 27 NPTF	MS1595	—	T30
5980812	EVSCTL3232P0432C	4	32	64	32	32	32	42	—	170	30	53	1/8 - 27 NPTF	1/8 - 27 NPTF	MS1970	—	T30
5980810	EVSCTL2525M0526C	5	26	62	25	25	25	34	—	150	23	47	1/8 - 27 NPTF	1/8 - 27 NPTF	MS1970	—	T30
5980811	EVSCTL2525M0532C	5	32	64	25	25	25	39	4	150	23	53	1/8 - 27 NPTF	1/8 - 27 NPTF	MS1970	—	T30
5980813	EVSCTL3232P0540C	5	40	82	32	32	32	47	4	170	30	63	1/8 - 27 NPTF	1/8 - 27 NPTF	MS1490	—	T45

NOTE: Through the pocket coolant available in seat sizes 3 and higher.

screw catalogue number	screw order number	torque		thread	socket	wrench catalogue number	wrench order number
		Nm	in. lbs.				
MS1160	1099645	7	62	M5	T20	KT20	1022703
MS1162	1127019	9	80	M6	T25	KT25	1022725
MS1163	1124104	18	159	M8	T30	KT30L	1099676
MS1273	1020977	4	35.4	M4	T15	KT15	1022701
MS1490	2263299	17	151	M8	T45	KT45	1018227
MS1595	1094300	12	106	M6	T30	KT30	1099676
MS1970	1106668	12	106	M6	T30	KT30	1099676
MS2002	1621087	9	80	M6	T25	KT25	1022725
MS2091	1931147	9	80	M5	25IP	K25IP	2050113

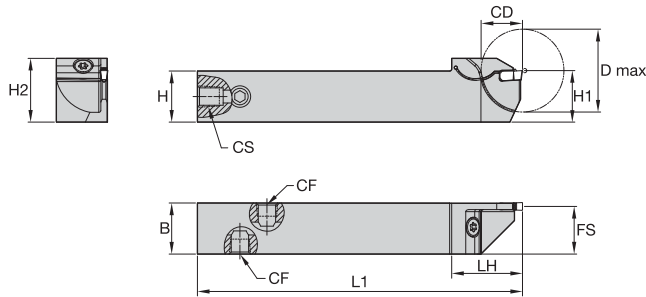

CD = Maximum cut-off depth for solid bars.  
D max = Maximum bar diameter for deep grooving or cut-off of tubes.

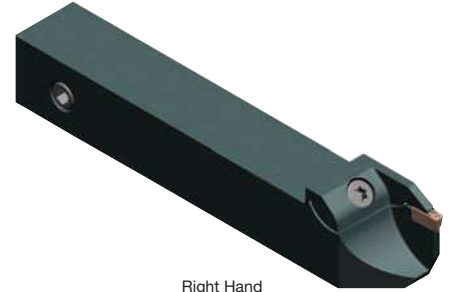

Grooving and Cut-Off

■ Integral Reinforced Front Clamp • Metric



order number	catalogue number	seat size	CD	D max	H1	H	B	H2	L1	FS	LH	CF	CS	Torx clamp screw	Torx
right hand															
6179763	EVSCFR1010K1B10	1B	10	20	10	10	10	14	125	9	21	—	—	191.916	T15
6179766	EVSCFR1212K1B10	1B	10	20	12	12	12	16	125	11	21	—	—	191.916	T15
6179767	EVSCFR1212K1B13	1B	13	26	12	12	12	16	125	11	24	—	—	191.916	T15
6179774	EVSCFR1616K1B16	1B	16	32	16	16	16	21	125	15	27	—	—	MS1160	T20
6179778	EVSCFR2020K1B16	1B	16	32	20	20	20	25	125	19	27	—	—	MS1160	T20
6179764	EVSCFR1010K1F10	1F	10	20	10	10	10	14	125	9	21	—	—	191.916	T15
6179768	EVSCFR1212K1F10	1F	10	20	12	12	12	16	125	11	21	—	—	191.916	T15
6179769	EVSCFR1212K1F13	1F	13	26	12	12	12	16	125	11	24	—	—	191.916	T15
6179775	EVSCFR1616K1F16	1F	16	32	16	16	16	21	125	15	27	—	—	MS1160	T20
6179779	EVSCFR2020K1F16	1F	16	32	20	20	20	25	125	19	27	—	—	MS1160	T20
6179765	EVSCFR1010K0210	2	10	20	10	10	10	14	125	9	21	—	—	191.916	T15
6179770	EVSCFR1212K0210	2	10	20	12	12	12	16	125	11	21	—	—	191.916	T15
6179771	EVSCFR1212K0216	2	16	32	12	12	12	16	125	11	27	—	—	191.916	T15
6179776	EVSCFR1616K0216	2	16	32	16	16	16	21	125	15	27	—	—	MS1160	T20
6179780	EVSCFR2020K0216	2	16	32	20	20	20	25	125	19	27	—	—	MS1160	T20
6179772	EVSCFR1212K0310C	3	10	20	12	12	12	17	125	11	22	M8X1.25	M8X1.25	191.916	T15
6179773	EVSCFR1212K0316C	3	16	32	12	12	12	17	125	11	28	M8X1.25	M8X1.25	191.916	T15
6179777	EVSCFR1616K0316C	3	16	32	16	16	16	21	125	15	28	M8X1.25	M8X1.25	MS1160	T20
6179781	EVSCFR2020K0316C	3	16	32	20	20	20	25	125	19	28	M8X1.25	M8X1.25	MS1160	T20

(continued)

(Integral Reinforced Front Clamp • Metric — continued)



Grooving and Cut-Off

order number	catalogue number	seat size	CD	D max	H1	H	B	H2	L1	FS	LH	CF	CS	Torx clamp screw	Torx
<b>left hand</b>															
6179709	EVSCFL1010K1B10	1B	10	20	10	10	10	14	125	9	21	—	—	191.916	T15
6179922	EVSCFL1212K1B10	1B	10	20	12	12	12	16	125	11	21	—	—	191.916	T15
6179923	EVSCFL1212K1B13	1B	13	26	12	12	12	16	125	11	24	—	—	191.916	T15
6179930	EVSCFL1616K1B16	1B	16	32	16	16	16	21	125	15	27	—	—	MS1160	T20
6179934	EVSCFL2020K1B16	1B	16	32	20	20	20	25	125	19	27	—	—	MS1160	T20
6179710	EVSCFL1010K1F10	1F	10	20	10	10	10	14	125	9	21	—	—	191.916	T15
6179924	EVSCFL1212K1F10	1F	10	20	12	12	12	16	125	11	21	—	—	191.916	T15
6179925	EVSCFL1212K1F13	1F	13	26	12	12	12	16	125	11	24	—	—	191.916	T15
6179931	EVSCFL1616K1F16	1F	16	32	16	16	16	21	125	15	27	—	—	MS1160	T20
6179935	EVSCFL2020K1F16	1F	16	32	20	20	20	25	125	19	27	—	—	MS1160	T20
6179921	EVSCFL1010K0210	2	10	20	10	10	10	14	125	9	21	—	—	191.916	T15
6179926	EVSCFL1212K0210	2	10	20	12	12	12	16	125	11	21	—	—	191.916	T15
6179927	EVSCFL1212K0216	2	16	32	12	12	12	16	125	11	27	—	—	191.916	T15
6179932	EVSCFL1616K0216	2	16	32	16	16	16	21	125	15	27	—	—	MS1160	T20
6179936	EVSCFL2020K0216	2	16	32	20	20	20	25	125	19	27	—	—	MS1160	T20
6179928	EVSCFL1212K0310C	3	10	20	12	12	12	17	125	11	22	M8X1.25	M8X1.25	191.916	T15
6179929	EVSCFL1212K0316C	3	16	32	12	12	12	17	125	11	28	M8X1.25	M8X1.25	191.916	T15
6179933	EVSCFL1616K0316C	3	16	32	16	16	16	21	125	15	28	M8X1.25	M8X1.25	MS1160	T20
6179937	EVSCFL2020K0316C	3	16	32	20	20	20	25	125	19	28	M8X1.25	M8X1.25	MS1160	T20

NOTE: Through the pocket coolant available in seat sizes 3 and higher.

screw catalogue number	screw order number	torque		thread	socket	wrench catalogue number	wrench order number
		Nm	in. lbs.				
MS1160	1099645	7	62	M5	T20	KT20	1022703
MS1162	1127019	9	80	M6	T25	KT25	1022725
MS1163	1124104	18	159	M8	T30	KT30L	1099676
MS1273	1020977	4	35.4	M4	T15	KT15	1022701
MS1490	2263299	17	151	M8	T45	KT45	1018227
MS1595	1094300	12	106	M6	T30	KT30	1099676
MS1970	1106668	12	106	M6	T30	KT30	1099676
MS2002	1621087	9	80	M6	T25	KT25	1022725
MS2091	1931147	9	80	M5	25IP	K25IP	2050113

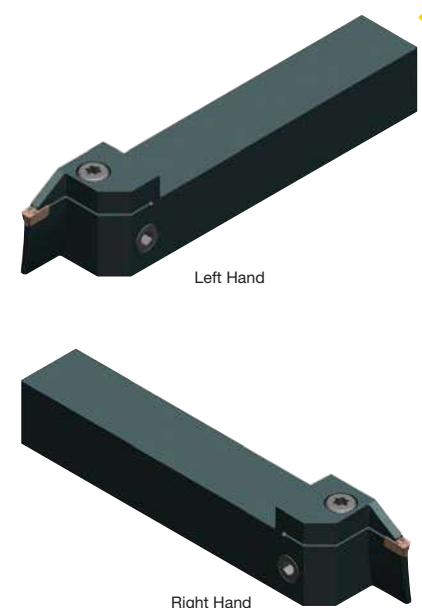
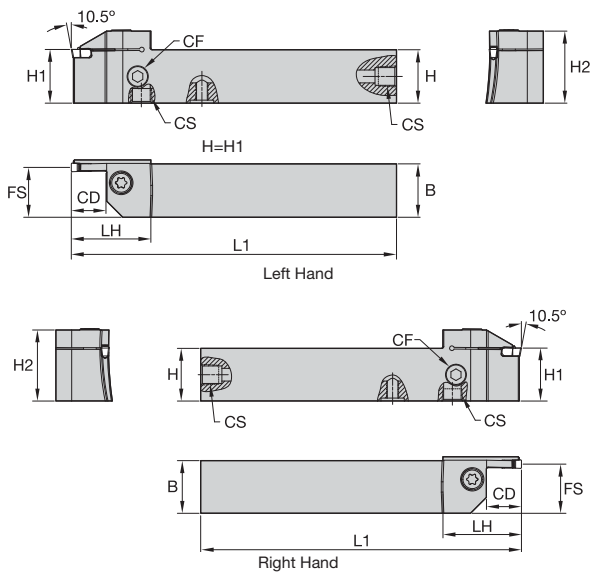

Grooving and Cut-Off

■ Integral Face Grooving Straight Outboard • Metric



order number	catalogue number	seat size	CD	D max	D min	W min	B	H2	L1	FS	LH	CF	CS	Torx clamp screw	Torx
<b>right hand</b>															
6080031	EVSBR2020K0312035040C	3	12	40	35	20	20	29	125	19	33	1/16 - 27 NPTF	1/16 - 27 NPTF	MS1595	T30
6116561	EVSBR2020K0312040050C	3	12	50	40	20	20	29	125	19	33	1/16 - 27 NPTF	1/16 - 27 NPTF	MS1595	T20
6116563	EVSBR2020K0312050060C	3	12	60	50	20	20	29	125	19	33	1/16 - 27 NPTF	1/16 - 27 NPTF	MS1595	T30
6116567	EVSBR2020K0312060075C	3	12	75	60	20	20	29	125	19	33	1/16 - 27 NPTF	1/16 - 27 NPTF	MS1595	T30
6116569	EVSBR2020K0312075100C	3	12	100	75	20	20	29	125	19	33	1/16 - 27 NPTF	1/16 - 27 NPTF	MS1595	T30
6080067	EVSBR2525M0312100180C	3	12	180	100	25	25	34	150	24	33	1/8 - 27 NPTF	1/8 - 27 NPTF	MS1970	T30
6080069	EVSBR2525M0312180250C	3	12	250	180	25	25	34	150	24	33	1/8 - 27 NPTF	1/8 - 27 NPTF	MS1970	T30
6080053	EVSBR2525M0320060075C	3	20	75	60	25	25	34	150	24	41	1/8 - 27 NPTF	1/8 - 27 NPTF	MS1970	T30
6080055	EVSBR2525M0320075100C	3	20	100	75	25	25	34	150	24	41	1/8 - 27 NPTF	1/8 - 27 NPTF	MS1970	T30
6080057	EVSBR2525M0320100180C	3	20	180	100	25	25	34	150	24	41	1/8 - 27 NPTF	1/8 - 27 NPTF	MS1970	T30
6080060	EVSBR2525M0320180250C	3	20	250	180	25	25	35	150	24	41	1/8 - 27 NPTF	1/8 - 27 NPTF	MS1970	T30
6080033	EVSBR2020K0416040050C	4	16	50	40	20	20	29	125	18	37	1/16 - 27 NPTF	1/16 - 27 NPTF	MS1595	T30
6080040	EVSBR2020K0416050060C	4	16	60	50	20	20	29	125	18	37	1/16 - 27 NPTF	1/16 - 27 NPTF	MS1595	T30
6116571	EVSBR2020K0416060075C	4	16	75	60	20	20	29	125	18	37	1/16 - 27 NPTF	1/16 - 27 NPTF	MS1595	T30
6116573	EVSBR2020K0416075100C	4	16	100	75	20	20	29	125	18	37	1/16 - 27 NPTF	1/16 - 27 NPTF	MS1595	T30
6116587	EVSBR2525M0416100180C	4	16	180	100	25	25	34	150	23	37	1/8 - 27 NPTF	1/8 - 27 NPTF	MS1970	T30
6116589	EVSBR2525M0416180250C	4	16	250	180	25	25	34	150	23	37	1/8 - 27 NPTF	1/8 - 27 NPTF	MS1970	T30
6116575	EVSBR2525M0426060075C	4	26	75	60	25	25	34	150	23	47	1/8 - 27 NPTF	1/8 - 27 NPTF	MS1970	T30
6116577	EVSBR2525M0426075100C	4	26	100	75	25	25	34	150	23	47	1/8 - 27 NPTF	1/8 - 27 NPTF	MS1970	T30
6116579	EVSBR2525M0426100180C	4	26	180	100	25	25	34	150	23	47	1/8 - 27 NPTF	1/8 - 27 NPTF	MS1970	T30
6116581	EVSBR2525M0426180250C	4	26	250	180	25	25	34	150	23	47	1/8 - 27 NPTF	1/8 - 27 NPTF	MS1970	T30
6080035	EVSBR2525M0516050060C	5	16	60	50	25	25	34	150	23	37	1/8 - 27 NPTF	1/8 - 27 NPTF	MS1970	T30
6124200	EVSBR2525M0516060075C	5	16	60	60	25	25	34	150	23	37	1/8 - 27 NPTF	1/8 - 27 NPTF	MS1970	T30

(continued)

(Integral Face Grooving Straight Outboard • Metric — continued)



Grooving and Cut-Off

order number	catalogue number	seat size	CD	D max	D min	W min	B	H2	L1	FS	LH	CF	CS	Torx clamp screw	Torx
6124214	EVSBR2525M0516075100C	5	16	100	75	25	25	34	150	23	37	1/8 - 27 NPTF	1/8 - 27 NPTF	MS1970	T30
6124218	EVSBR2525M0516100180C	5	16	180	100	25	25	34	150	23	37	1/8 - 27 NPTF	1/8 - 27 NPTF	MS1970	T30
6124222	EVSBR2525M0516180250C	5	16	250	180	25	25	34	150	23	37	1/8 - 27 NPTF	1/8 - 27 NPTF	MS1970	T30
6124226	EVSBR2525M0516250350C	5	16	350	250	25	25	34	150	23	37	1/8 - 27 NPTF	1/8 - 27 NPTF	MS1970	T30
6124230	EVSBR2525M0516350999C	5	16	999	350	25	25	34	150	23	37	1/8 - 27 NPTF	1/8 - 27 NPTF	MS1970	T30
6124198	EVSBR2525M0526050060C	5	26	60	50	25	25	35	150	23	47	1/8 - 27 NPTF	1/8 - 27 NPTF	MS1970	T30
6124212	EVSBR2525M0526060075C	5	26	60	60	25	25	35	150	23	47	1/8 - 27 NPTF	1/8 - 27 NPTF	MS1970	T30
6124216	EVSBR2525M0526075100C	5	26	100	75	25	25	35	150	23	47	1/8 - 27 NPTF	1/8 - 27 NPTF	MS1970	T30
6124235	EVSBR3232P0532100180C	5	32	180	100	32	32	42	170	30	53	1/8 - 27 NPTF	1/8 - 27 NPTF	MS1970	T30
6124237	EVSBR3232P0532180250C	5	32	250	180	32	32	42	170	30	53	1/8 - 27 NPTF	1/8 - 27 NPTF	MS1970	T30
6124239	EVSBR3232P0532250350C	5	32	350	250	32	32	42	170	30	53	1/8 - 27 NPTF	1/8 - 27 NPTF	MS1970	T30
6124241	EVSBR3232P0532350999C	5	32	999	350	32	32	42	170	30	53	1/8 - 27 NPTF	1/8 - 27 NPTF	MS1970	T30
6124605	EVSBR2525M0616060075C	6	16	75	60	25	25	35	150	22	37	1/8 - 27 NPTF	1/8 - 27 NPTF	MS1970	T30
6124609	EVSBR2525M0616075100C	6	16	100	75	25	25	35	150	22	37	1/8 - 27 NPTF	1/8 - 27 NPTF	MS1970	T30
6124673	EVSBR2525M0616100180C	6	16	180	100	25	25	31	150	22	37	1/8 - 27 NPTF	1/8 - 27 NPTF	MS1970	T30
6124677	EVSBR2525M0616180250C	6	16	250	180	25	25	34	150	22	37	1/8 - 27 NPTF	1/8 - 27 NPTF	MS1970	T30
6124681	EVSBR2525M0616250350C	6	16	350	250	25	25	34	150	22	37	1/8 - 27 NPTF	1/8 - 27 NPTF	MS1970	T30
6124685	EVSBR2525M0616350999C	6	16	999	350	25	25	34	150	22	37	1/8 - 27 NPTF	1/8 - 27 NPTF	MS1970	T30
6124607	EVSBR2525M0626060075C	6	26	75	60	25	25	35	150	22	47	1/8 - 27 NPTF	1/8 - 27 NPTF	MS1970	T30
6124671	EVSBR2525M0626075100C	6	26	100	75	25	25	35	150	22	47	1/8 - 27 NPTF	1/8 - 27 NPTF	MS1970	T30
6124689	EVSBR3232P0632100180C	6	32	180	100	32	32	43	170	29	55	1/8 - 27 NPTF	1/8 - 27 NPTF	MS1490	T45
6124691	EVSBR3232P0632180250C	6	32	250	180	32	32	43	170	29	55	1/8 - 27 NPTF	1/8 - 27 NPTF	MS1490	T45
6124693	EVSBR3232P0632250350C	6	32	350	250	32	32	43	170	29	55	1/8 - 27 NPTF	1/8 - 27 NPTF	MS1490	T45
6124695	EVSBR3232P0632350999C	6	32	999	350	32	32	43	170	29	55	1/8 - 27 NPTF	1/8 - 27 NPTF	MS1490	T45
<b>left hand</b>															
6080037	EVSBL2020K0312035040C	3	12	40	35	20	20	29	125	19	33	1/16 - 27 NPTF	1/16 - 27 NPTF	MS1595	T30
6116562	EVSBL2020K0312040050C	3	12	50	40	20	20	29	125	19	33	1/16 - 27 NPTF	1/16 - 27 NPTF	MS1595	T30
6116564	EVSBL2020K0312050060C	3	12	60	50	20	20	29	125	19	33	1/16 - 27 NPTF	1/16 - 27 NPTF	MS1595	T30
6116568	EVSBL2020K0312060075C	3	12	75	60	20	20	29	125	19	33	1/16 - 27 NPTF	1/16 - 27 NPTF	MS1595	T30
6116570	EVSBL2020K0312075100C	3	12	100	75	20	20	29	125	19	33	1/16 - 27 NPTF	1/16 - 27 NPTF	MS1595	T30
6080068	EVSBL2525M0312100180C	3	12	180	100	25	25	34	150	24	33	1/8 - 27 NPTF	1/8 - 27 NPTF	MS1970	T30
6080070	EVSBL2525M0312180250C	3	12	250	180	25	25	34	150	24	33	1/8 - 27 NPTF	1/8 - 27 NPTF	MS1970	T30
6080054	EVSBL2525M0320060075C	3	20	75	60	25	25	35	150	24	41	1/8 - 27 NPTF	1/8 - 27 NPTF	MS1970	T30
6080056	EVSBL2525M0320075100C	3	20	100	75	25	25	35	150	24	41	1/8 - 27 NPTF	1/8 - 27 NPTF	MS1970	T30
6080059	EVSBL2525M0320100180C	3	20	180	100	25	25	35	150	24	41	1/8 - 27 NPTF	1/8 - 27 NPTF	MS1970	T30
6080061	EVSBL2525M0320180250C	3	20	250	180	25	25	35	150	24	41	1/8 - 27 NPTF	1/8 - 27 NPTF	MS1970	T30
6080038	EVSBL2020K0416040050C	4	16	50	40	20	20	29	125	18	37	1/16 - 27 NPTF	1/16 - 27 NPTF	MS1595	T30
6080051	EVSBL2020K0416050060C	4	16	60	50	20	20	29	125	18	37	1/16 - 27 NPTF	1/16 - 27 NPTF	MS1595	T30
6116572	EVSBL2020K0416060075C	4	16	75	60	20	20	29	125	18	37	1/16 - 27 NPTF	1/16 - 27 NPTF	MS1595	T30
6116574	EVSBL2020K0416075100C	4	16	100	75	20	20	29	125	18	37	1/16 - 27 NPTF	1/16 - 27 NPTF	MS1595	T30
6116588	EVSBL2525M0416100180C	4	16	180	100	25	25	34	150	23	37	1/8 - 27 NPTF	1/8 - 27 NPTF	MS1970	T30
6116590	EVSBL2525M0416180250C	4	16	250	180	25	25	34	150	23	37	1/8 - 27 NPTF	1/8 - 27 NPTF	MS1970	T30
6116576	EVSBL2525M0426060075C	4	26	75	60	25	25	35	150	23	47	1/8 - 27 NPTF	1/8 - 27 NPTF	MS1970	T30
6116578	EVSBL2525M0426075100C	4	26	100	75	25	25	35	150	23	47	1/8 - 27 NPTF	1/8 - 27 NPTF	MS1970	T30

(continued)

(Integral Face Grooving Straight Outboard • Metric — continued)



order number	catalogue number	seat size	CD	D max	D min	W min	B	H2	L1	FS	LH	CF	CS	Torx clamp screw	Torx
														MS1970	T30
6116580	EVSBL2525M0426100180C	4	26	180	100	25	25	35	150	23	47	1/8 - 27 NPTF	1/8 - 27 NPTF	MS1970	T30
6116582	EVSBL2525M0426180250C	4	26	250	180	25	25	35	150	23	47	1/8 - 27 NPTF	1/8 - 27 NPTF	MS1970	T30
6080039	EVSBL2525M0516050060C	5	16	60	50	25	25	34	150	23	37	1/8 - 27 NPTF	1/8 - 27 NPTF	MS1970	T30
6124211	EVSBL2525M0516060075C	5	16	60	60	25	25	34	150	23	37	1/8 - 27 NPTF	1/8 - 27 NPTF	MS1970	T30
6124215	EVSBL2525M0516075100C	5	16	100	75	25	25	34	150	23	37	1/8 - 27 NPTF	1/8 - 27 NPTF	MS1970	T30
6124219	EVSBL2525M0516100180C	5	16	180	100	25	25	34	150	23	37	1/8 - 27 NPTF	1/8 - 27 NPTF	MS1970	T30
6124223	EVSBL2525M0516180250C	5	16	250	180	25	25	34	150	23	37	1/8 - 27 NPTF	1/8 - 27 NPTF	MS1970	T30
6124227	EVSBL2525M0516250350C	5	16	350	250	25	25	34	150	23	37	1/8 - 27 NPTF	1/8 - 27 NPTF	MS1970	T30
6124232	EVSBL2525M0516350999C	5	16	999	350	25	25	34	150	23	37	1/8 - 27 NPTF	1/8 - 27 NPTF	MS1970	T30
6124199	EVSBL2525M0526050060C	5	26	60	50	25	25	35	150	23	47	1/8 - 27 NPTF	1/8 - 27 NPTF	MS1970	T30
6124213	EVSBL2525M0526060075C	5	26	60	60	25	25	35	150	23	47	1/8 - 27 NPTF	1/8 - 27 NPTF	MS1970	T30
6124217	EVSBL2525M0526075100C	5	26	100	75	25	25	35	150	23	47	1/8 - 27 NPTF	1/8 - 27 NPTF	MS1970	T30
6124236	EVSBL3232P0532100180C	5	32	180	100	32	32	42	170	30	53	1/8 - 27 NPTF	1/8 - 27 NPTF	MS1970	T30
6124238	EVSBL3232P0532180250C	5	32	250	180	32	32	42	170	30	53	1/8 - 27 NPTF	1/8 - 27 NPTF	MS1970	T30
6124240	EVSBL3232P0532250350C	5	32	350	250	32	32	42	170	30	53	1/8 - 27 NPTF	1/8 - 27 NPTF	MS1970	T30
6124242	EVSBL3232P0532350999C	5	32	999	350	32	32	42	170	30	53	1/8 - 27 NPTF	1/8 - 27 NPTF	MS1970	T30
6124606	EVSBL2525M0616060075C	6	16	75	60	25	25	35	150	22	37	1/8 - 27 NPTF	1/8 - 27 NPTF	MS1970	T30
6124610	EVSBL2525M0616075100C	6	16	100	75	25	25	35	150	22	37	1/8 - 27 NPTF	1/8 - 27 NPTF	MS1970	T30
6124674	EVSBL2525M0616100180C	6	16	180	100	25	25	35	150	22	37	1/8 - 27 NPTF	1/8 - 27 NPTF	MS1970	T30
6124678	EVSBL2525M0616180250C	6	16	250	180	25	25	35	150	22	37	1/8 - 27 NPTF	1/8 - 27 NPTF	MS1970	T30
6124682	EVSBL2525M0616250350C	6	16	350	250	25	25	35	150	22	37	1/8 - 27 NPTF	1/8 - 27 NPTF	MS1970	T30
6124686	EVSBL2525M0616350999C	6	16	999	350	25	25	35	150	22	37	1/8 - 27 NPTF	1/8 - 27 NPTF	MS1970	T30
6124608	EVSBL2525M0626060075C	6	26	75	60	25	25	35	150	22	47	1/8 - 27 NPTF	1/8 - 27 NPTF	MS1970	T30
6124672	EVSBL2525M0626075100C	6	26	100	75	25	25	35	150	22	47	1/8 - 27 NPTF	1/8 - 27 NPTF	MS1970	T30
6124690	EVSBL3232P0632100180C	6	32	180	100	32	32	43	170	29	55	1/8 - 27 NPTF	1/8 - 27 NPTF	MS1490	T45
6124692	EVSBL3232P0632180250C	6	32	250	180	32	32	43	170	29	55	1/8 - 27 NPTF	1/8 - 27 NPTF	MS1490	T45
6124694	EVSBL3232P0632250350C	6	32	350	250	32	32	43	170	29	55	1/8 - 27 NPTF	1/8 - 27 NPTF	MS1490	T45
6124696	EVSBL3232P0632350999C	6	32	999	350	32	32	43	170	29	55	1/8 - 27 NPTF	1/8 - 27 NPTF	MS1490	T45

NOTE: Through the pocket coolant available in seat sizes 3 and higher.

screw catalogue number	screw order number	torque		thread	socket	wrench catalogue number	wrench order number
		Nm	in. lbs.				
MS1160	1099645	7	62	M5	T20	KT20	1022703
MS1162	1127019	9	80	M6	T25	KT25	1022725
MS1163	1124104	18	159	M8	T30	KT30L	1099676
MS1273	1020977	4	35.4	M4	T15	KT15	1022701
MS1490	2263299	17	151	M8	T45	KT45	1018227
MS1595	1094300	12	106	M6	T30	KT30	1099676
MS1970	1106668	12	106	M6	T30	KT30	1099676
MS2002	1621087	9	80	M6	T25	KT25	1022725
MS2091	1931147	9	80	M5	25IP	K25IP	2050113

- For use in I.D. grooving applications.
- Maximum support.
- Steel boring bar with through coolant capability.

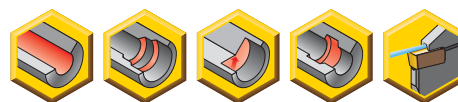

Grooving and Cut-Off

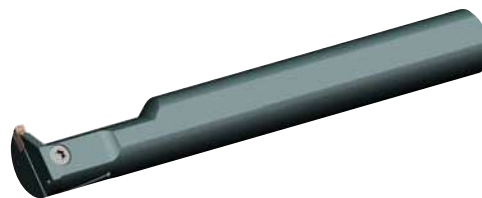
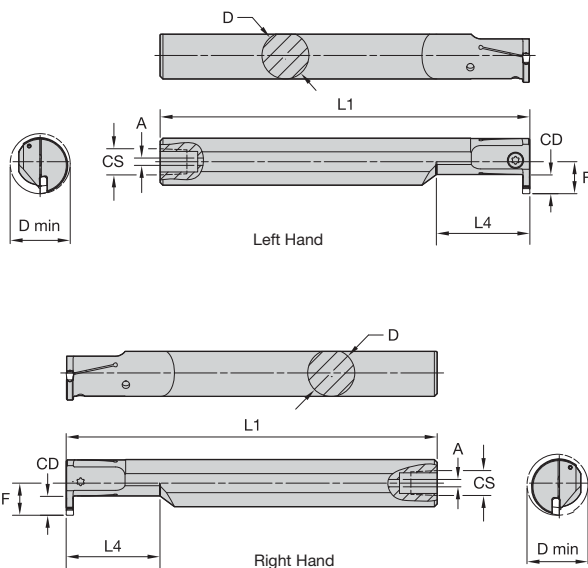

Left Hand



Right Hand

## Steel Boring Bar • Metric

order number	catalogue number	seat size	CD	D	D min	L1	F	L4	A	CS	Torx clamp screw	Torx clamp screw	Torx
<b>right hand</b>													
5980518	A12KEVEMR1F05M	1F	5,00	12	16	125	9	24,0	4,00	1/16 - 27 NPT	—	MS1285	T15
5980520	A16MEVEMR1F07M	1F	7,00	16	20	150	11	32,0	4,00	1/8 - 27 NPT	—	MS1273	T15
5980622	A20QEVEMR1F07M	1F	7,00	20	25	180	13	40,0	4,00	1/8 - 27 NPTF	—	MS1160	T20
5980519	A12KEVEMR0205M	2	5,00	12	16	125	9	24,0	4,00	1/16 - 27 NPTF	—	MS1285	T15
5980621	A16MEVEMR0207M	2	7,00	16	20	150	11	32,0	4,00	1/8 - 27 NPTF	—	MS1273	T15
5980623	A20QEVEMR0207M	2	7,00	20	25	180	13	40,0	4,00	1/8 - 27 NPTF	—	MS1160	T20
5980624	A25REVEMR0210M	2	10,00	25	32	200	18	50,0	6,40	1/4 - 18 NPT	—	MS1162	T25
5954259	A16MEVEMR0307M	3	7,00	16	20	150	11	40,3	4,00	1/8 - 27 NPT	—	MS1273	T15
5954260	A20QEVEMR0307M	3	7,00	20	25	180	13	40,3	4,00	1/8 - 27 NPT	—	MS1160	T20
5954281	A25REVEMR0310M	3	10,00	25	32	200	17	50,3	6,40	1/4 - 18 NPT	—	MS1162	T25
5954283	A32SEVEMR0312M	3	12,00	32	40	250	22	64,0	6,40	1/4 - 18 NPT	MS1595	—	T30
5954282	A25REVEMR0410M	4	10,00	25	32	200	17	50,3	6,40	1/4 - 18 NPT	—	MS1162	T25
5954284	A32SEVEMR0412M	4	12,00	32	40	250	22	64,0	6,40	1/4 - 18 NPT	MS1595	—	T30

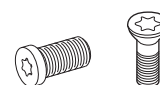

(continued)

(Steel Boring Bar • Metric — continued)



order number	catalogue number	seat size	CD	D	D min	L1	F	L4	A	CS	Torx clamp screw	Torx clamp screw	Torx
left hand													
5980625	A12KEVEML1F05M	1F	5,00	12	16	125	9	24,0	4,00	1/16 - 27 NPTF	—	MS1285	T15
5980627	A16MEVEML1F07M	1F	7,00	16	20	150	11	32,0	4,00	1/8 - 27 NPTF	—	MS1273	T15
5980629	A20QEVEML1F07M	1F	7,00	20	25	180	13	40,0	4,00	1/8 - 27 NPTF	—	MS1160	T20
5980626	A12KEVEML0205M	2	5,00	12	16	125	9	24,0	4,00	1/16 - 27 NPTF	—	MS1285	T15
5980628	A16MEVEML0207M	2	7,00	16	20	150	11	32,0	4,00	1/8 - 27 NPTF	—	MS1273	T15
5980630	A20QEVEML0207M	2	7,00	20	25	180	13	40,0	4,00	1/8 - 27 NPTF	—	MS1160	T20
5980631	A25REVEML0210M	2	10,00	25	32	200	18	50,0	6,40	1/4 - 18 NPT	—	MS1162	T25
5954285	A16MEVEML0307M	3	7,00	16	20	150	11	40,3	4,00	1/8 - 27 NPT	—	MS1273	T15
5954286	A20QEVEML0307M	3	7,00	20	25	180	13	40,3	4,00	1/8 - 27 NPT	—	MS1160	T20
5954287	A25REVEML0310M	3	10,00	25	32	200	17	50,3	6,40	1/4 - 27 NPT	—	MS1162	T25
5954289	A32SEVEML0312M	3	12,00	32	40	250	22	64,0	6,40	1/4 - 27 NPT	MS1595	—	T30
5954288	A25REVEML0410M	4	10,00	25	32	200	17	50,3	6,40	1/4 - 18 NPT	—	MS1162	T25
5954290	A32SEVEML0412M	4	12,00	32	40	250	22	64,0	6,40	1/4 - 18 NPT	MS1595	—	T30

screw catalogue number	screw order number	torque		thread	socket	wrench catalogue number	wrench order number
		Nm	in. lbs.				
MS1160	1099645	7	62	M5	T20	KT20	1022703
MS1162	1127019	9	80	M6	T25	KT25	1022725
MS1163	1124104	18	159	M8	T30	KT30L	1099676
MS1273	1020977	4	35.4	M4	T15	KT15	1022701
MS1490	2263299	17	151	M8	T45	KT45	1018227
MS1595	1094300	12	106	M6	T30	KT30	1099676
MS1970	1106668	12	106	M6	T30	KT30	1099676
MS2002	1621087	9	80	M6	T25	KT25	1022725
MS2091	1931147	9	80	M5	25IP	K25IP	2050113

Grooving and Cut-Off





Grooving and Cut-Off

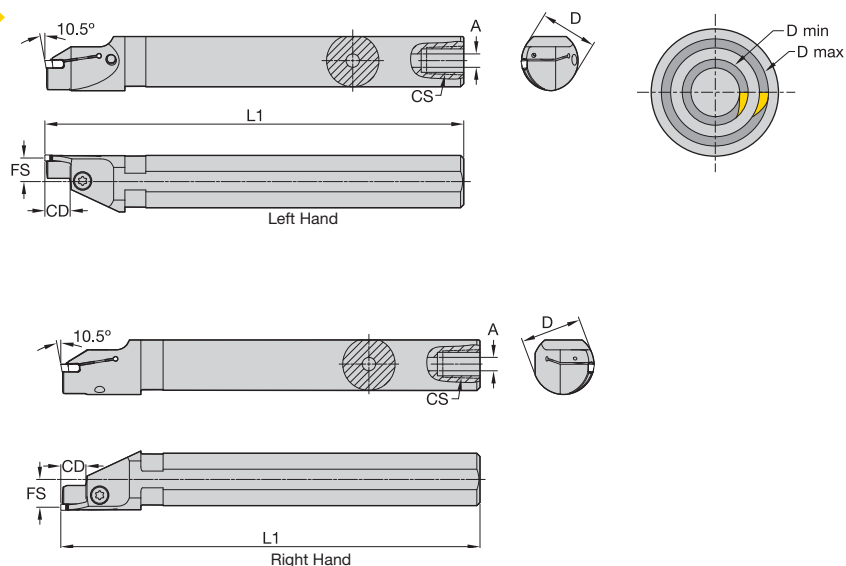

Left Hand



Right Hand

### ■ Steel Face Grooving Boring Bar • Metric



order number	catalogue number	seat size	CD	D	D min	D max	L1	F	CS	Torx clamp screw	Torx
<b>right hand</b>											
6116521	A25REVSAR0212M026030	2	12,00	25	26	30	200	13	1/4-18 NPT	MS1160	T20
6116522	A25REVSAR0312M030035	3	12,00	25	30	35	200	13	—	MS1162	T25
6116297	A32SEVSAR0312M033042	3	12,00	32	33	42	250	16	1/4-18 NPT	MS1162	T25
6116299	A40TEVSAR0312M041050	3	12,00	40	41	50	300	20	1/4-18 NPT	MS1162	T25
<b>left hand</b>											
6116527	A25REVSAL0212M026030	2	12,00	25	26	30	200	13	1/4-18 NPT	MS1160	T20
6116528	A25REVSAL0312M030035	3	12,00	25	30	35	200	13	1/4-18 NPT	MS1162	T25
6116298	A32SEVSAL0312M033042	3	12,00	32	33	42	250	16	1/4-18 NPT	—	T25
6116300	A40TEVSAL0312M041050	3	12,00	40	41	50	300	20	1/4-18 NPT	MS1162	T25

screw catalogue number	screw order number	torque		thread	socket	wrench catalogue number	wrench order number
		Nm	in. lbs.				
MS1160	1099645	7	62	M5	T20	KT20	1022703
MS1162	1127019	9	80	M6	T25	KT25	1022725
MS1163	1124104	18	159	M8	T30	KT30L	1099676
MS1273	1020977	4	35.4	M4	T15	KT15	1022701
MS1490	2263299	17	151	M8	T45	KT45	1018227
MS1595	1094300	12	106	M6	T30	KT30	1099676
MS1970	1106668	12	106	M6	T30	KT30	1099676
MS2002	1621087	9	80	M6	T25	KT25	1022725
MS2091	1931147	9	80	M5	25IP	K25IP	2050113

- For deep groove and cut-off applications.
- Universal pocket for holding all insert geometries.

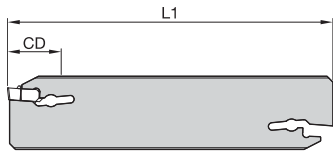
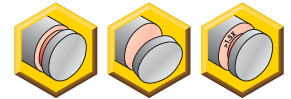

Straight

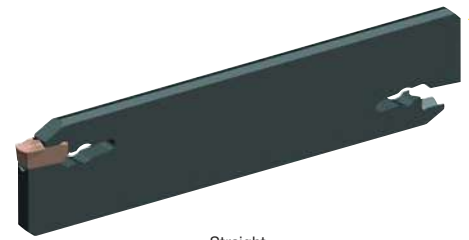
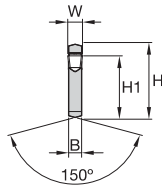

Straight

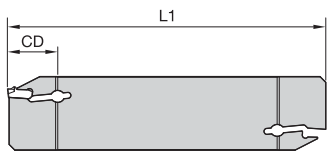

Reinforced

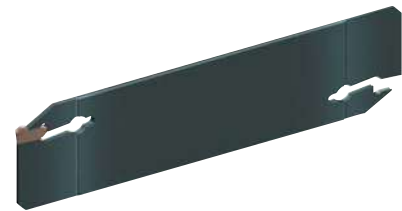
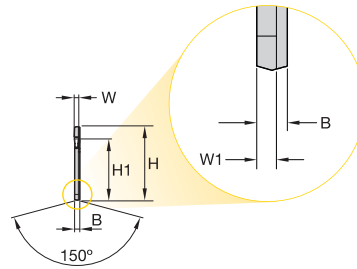

Reinforced

Grooving and Cut-Off

### Double-Ended Cut-Off Blade



order number	catalogue number	seat size	H	W	W1	H1	L1	B	CD	assembly wrench
left hand										
5941706	EVBSN19G1B14	1B	19	1,4	1,15	15,5	90	1,80	14	SCW5E
5941708	EVBSN26J1B15	1B	26	1,4	1,15	21,5	110	1,80	15	SCW5E
5955391	EVBSN19G1F16	1F	19	1,6	1,30	15,5	90	1,80	16	SCW5E
5955392	EVBSN26J1F17	1F	26	1,6	1,30	21,5	110	1,80	17	SCW5E
5941707	EVBSN19G0220	2	19	2,0	—	15,5	90	1,65	—	SCW5E
5941709	EVBSN26J0230	2	26	2,0	—	21,5	110	1,65	—	SCW5E
5941710	EVBSN26M0230	2	26	2,0	—	21,5	150	1,65	—	SCW5E
5941724	EVBSN32M0250	2	32	2,0	—	25,1	150	1,65	—	SCW5E
5941721	EVBSN26J0340	3	26	3,0	—	21,5	110	2,40	—	SCW5E
5941722	EVBSN26M0340	3	26	3,0	—	21,5	150	2,40	—	SCW5E
5941725	EVBSN32M0350	3	32	3,0	—	25,1	150	2,40	—	SCW5E
5941723	EVBSN26J0440	4	26	4,0	—	21,5	110	3,40	—	SCW5E
5941726	EVBSN32M0450	4	32	4,0	—	25,1	150	3,40	—	SCW5E
5977635	EVBSN26J0540	5	26	5,0	—	21,5	110	4,40	—	SCW5E
5977637	EVBSN32M0560	5	32	5,0	—	25,1	150	4,40	—	SCW5E
5977636	EVBSN26J0640	6	26	6,0	—	21,5	110	5,40	—	SCW8E
5977638	EVBSN32M0660	6	32	6,0	—	25,1	150	5,40	—	SCW8E
5977640	EVBSN52X06120	6	53	6,0	—	45,3	260	5,40	—	SCW8E
5977639	EVBSN32M0860	8	32	8,0	—	25,1	150	7,00	—	SCW8E
5977721	EVBSN52X08120	8	53	8,0	—	45,3	260	7,00	—	SCW8E

NOTE: Assembly wrench supplied with blade.

- Maximum support for specific groove width and straight clearance for unlimited diameter.
- Through the pocket coolant capable.
- Universal pocket for holding all insert geometries.

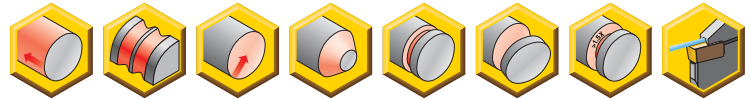

Grooving and Cut-Off

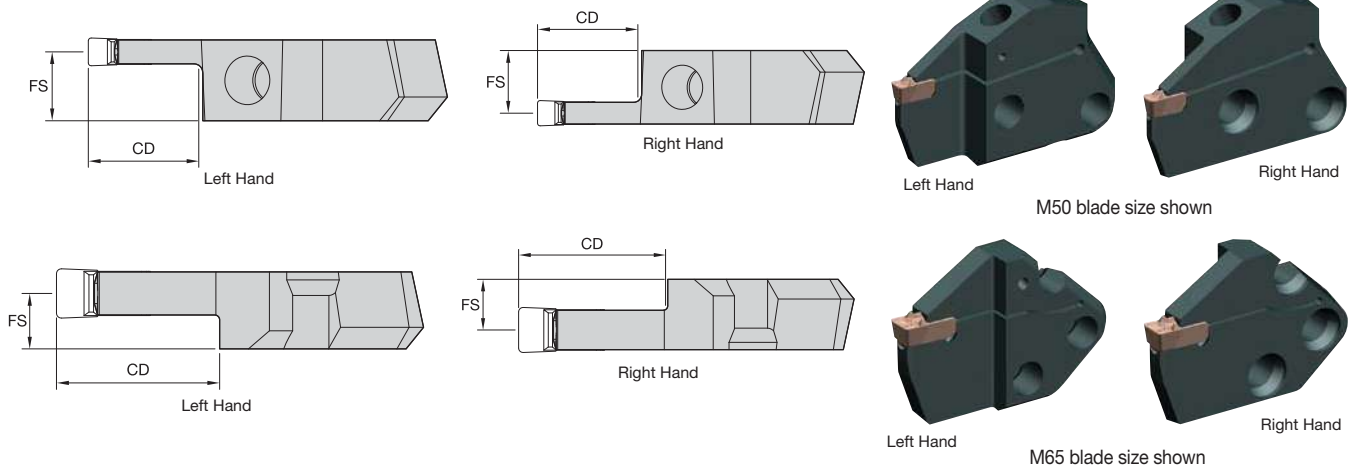

### ■ Modular Straight Blade with Coolant

order number	catalogue number	seat size	CD	FS	blade size
<b>right hand</b>					
6031041	EVM50R1F12M	1F	12,0	11,00	50
6030969	EVM50R0212M	2	12,0	10,88	50
5955423	EVM50R0216M	2	16,0	10,88	50
5979200	EVM50R0312MC	3	12,0	10,43	50
5979010	EVM50R0316MC	3	16,0	10,43	50
5979181	EVM50R0322MC	3	22,0	10,43	50
5979201	EVM50R0412MC	4	12,0	9,93	50
5979182	EVM50R0416MC	4	16,0	9,93	50
5979183	EVM50R0422MC	4	22,0	9,93	50
5979198	EVM50R0426MC	4	26,0	9,93	50
5979184	EVM50R0432MC	4	32,0	9,93	50
6031031	EVM50R0512MC	5	12,0	9,43	50
6031033	EVM50R0516MC	5	16,0	9,43	50
5955415	EVM50R0526MC	5	26,0	9,43	50
5955416	EVM50R0532MC	5	32,0	9,43	50
6031035	EVM65R0616MC	6	16,0	9,88	65
5955417	EVM65R0626MC	6	26,0	9,88	65
6031037	EVM65R0632MC	6	32,0	9,88	65
6031039	EVM65R0816MC	8	16,0	9,00	65
5955418	EVM65R0826MC	8	26,0	9,00	65

(continued)

(Modular Straight Blade with Coolant — continued)

order number	catalogue number	seat size	CD	FS	blade size
left hand					
6031042	EVM50L1F12M	1F	12,0	11,00	50
6030970	EVM50L0212M	2	12,0	10,88	50
5955424	EVM50L0216M	2	16,0	10,88	50
5979202	EVM50L0312MC	3	12,0	10,43	50
5979185	EVM50L0316MC	3	16,0	10,43	50
5979186	EVM50L0322MC	3	22,0	10,43	50
5979203	EVM50L0412MC	4	12,0	9,93	50
5979187	EVM50L0416MC	4	16,0	9,93	50
5979188	EVM50L0422MC	4	22,0	9,93	50
5979199	EVM50L0426MC	4	26,0	9,93	50
5979189	EVM50L0432MC	4	32,0	9,93	50
6031032	EVM50L0512MC	5	12,0	9,93	50
6031034	EVM50L0516MC	5	16,0	9,43	50
5955419	EVM50L0526MC	5	26,0	9,43	50
5955420	EVM50L0532MC	5	32,0	9,43	50
6031036	EVM65L0616MC	6	16,0	9,88	65
5955421	EVM65L0626MC	6	26,0	9,88	65
6031038	EVM65L0632MC	6	32,0	9,88	65
6031040	EVM65L0816MC	8	16,0	9,00	65
5955422	EVM65L0826MC	8	26,0	9,00	65

NOTE: Through the pocket coolant available in seat sizes 3 and higher.



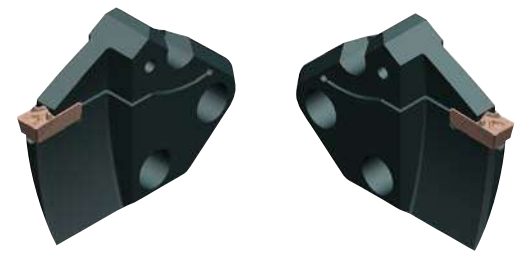
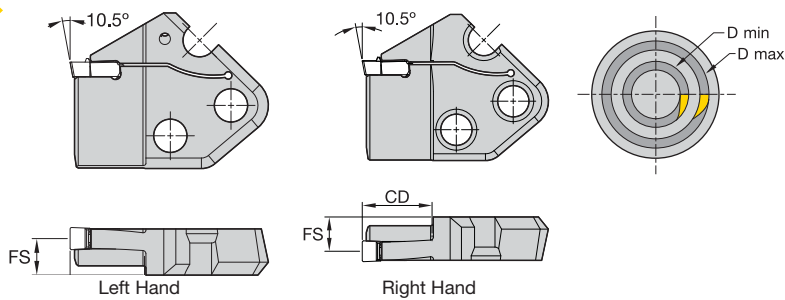
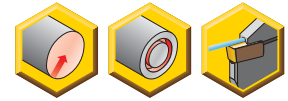

Left Hand Right Hand  
M65 blade size shown

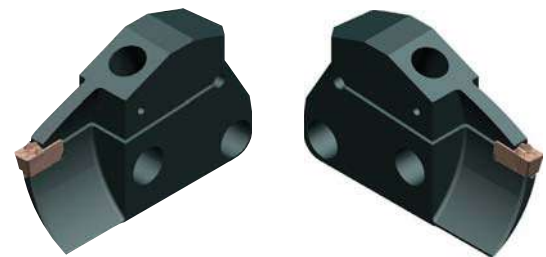
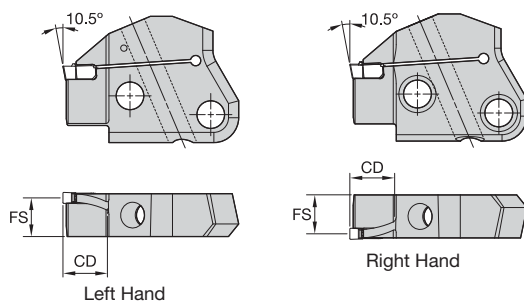

Left Hand Right Hand  
M50 blade size shown

## ■ Modular Inboard Face Grooving Blade with Coolant

order number	catalogue number	seat size	D min	D max	CD	FS	blade size
<b>right hand</b>							
6097181	EVM50R0312A035040C	3	35	40	12,0	10,50	50
6097182	EVM50R0312A040050C	3	40	50	12,0	10,50	50
6097183	EVM50R0312A050060C	3	50	60	12,0	10,50	50
6097184	EVM50R0312A060075C	3	60	75	12,0	10,50	50
6116789	EVM50R0312A075100C	3	75	100	12,0	10,50	50
6117063	EVM50R0312A100180C	3	100	180	12,0	10,50	50
6117067	EVM50R0312A180250C	3	180	250	12,0	10,50	50
6117071	EVM50R0312A250350C	3	250	350	12,0	10,50	50
6117075	EVM50R0312A350999C	3	350	999	12,0	10,50	50
6097185	EVM50R0320A075100C	3	75	100	20,0	10,50	50
6097186	EVM50R0320A100180C	3	100	180	20,0	10,50	50
6097187	EVM50R0320A180250C	3	180	250	20,0	10,50	50
6097188	EVM50R0320A250350C	3	250	350	20,0	10,50	50
6097189	EVM50R0320A350999C	3	350	999	20,0	10,50	50
6079480	EVM50R0416A040050C	4	40	50	16,0	10,00	50
6079481	EVM50R0416A050060C	4	50	60	16,0	10,00	50
6079482	EVM50R0416A060075C	4	60	75	16,0	10,00	50
6079483	EVM50R0416A075100C	4	75	100	16,0	10,00	50
6117079	EVM50R0416A100180C	4	100	180	16,0	10,00	50
6117093	EVM50R0416A180250C	4	180	250	16,0	10,00	50
6117097	EVM50R0416A250350C	4	250	350	16,0	10,00	50
6117101	EVM50R0416A350999C	4	350	999	16,0	10,00	50
6079484	EVM50R0426A100180C	4	100	180	26,0	10,00	50

(continued)

(Modular Inboard Face Grooving Blade with Coolant — continued)

order number	catalogue number	seat size	D min	D max	CD	FS	blade size
6079485	EVM50R0426A180250C	4	180	250	26,0	10,00	50
6079486	EVM50R0426A250350C	4	250	350	26,0	10,00	50
6079487	EVM50R0426A350999C	4	350	999	26,0	10,00	50
6079488	EVM50R0520A050060C	5	50	60	20,0	9,50	50
6079489	EVM50R0520A060075C	5	60	75	20,0	9,50	50
6079490	EVM50R0520A075100C	5	75	100	20,0	9,50	50
6079491	EVM50R0520A100180C	5	100	180	20,0	9,50	50
6079492	EVM50R0520A180250C	5	180	250	20,0	9,50	50
6079493	EVM50R0520A250350C	5	250	350	20,0	9,50	50
6079494	EVM50R0520A350999C	5	350	999	20,0	9,50	50
6079223	EVM65R0620A060075C	6	60	75	20,0	9,88	65
6079224	EVM65R0620A075100C	6	75	100	20,0	9,88	65
6079225	EVM65R0620A100180C	6	100	180	20,0	9,88	65
6079226	EVM65R0620A180250C	6	180	250	20,0	9,88	65
6079227	EVM65R0620A250350C	6	250	350	20,0	9,88	65
6079228	EVM65R0620A350999C	6	350	999	20,0	9,88	65
6079229	EVM65R0820A080180C	8	80	180	20,0	9,00	65
6079230	EVM65R0820A180999C	8	180	999	20,0	9,00	65
<b>left hand</b>							
6097190	EVM50L0312A035040C	3	35	40	12,0	10,50	50
6097191	EVM50L0312A040050C	3	40	50	12,0	10,50	50
6097192	EVM50L0312A050060C	3	50	60	12,0	10,50	50
6097193	EVM50L0312A060075C	3	60	75	12,0	10,50	50
6116790	EVM50L0312A075100C	3	75	100	12,0	10,50	50
6117064	EVM50L0312A100180C	3	100	180	12,0	10,50	50
6117068	EVM50L0312A180250C	3	180	250	12,0	10,50	50
6117072	EVM50L0312A250350C	3	250	350	12,0	10,50	50
6117076	EVM50L0312A350999C	3	350	999	12,0	10,50	50
6097194	EVM50L0320A075100C	3	75	100	20,0	10,50	50
6097195	EVM50L0320A100180C	3	100	180	20,0	10,50	50
6097196	EVM50L0320A180250C	3	180	250	20,0	10,50	50
6097197	EVM50L0320A250350C	3	250	350	20,0	10,50	50
6097198	EVM50L0320A350999C	3	350	999	20,0	10,50	50
6079495	EVM50L0416A040050C	4	40	50	16,0	10,00	50
6079496	EVM50L0416A050060C	4	50	60	16,0	10,00	50
6079497	EVM50L0416A060075C	4	60	75	16,0	10,00	50
6079498	EVM50L0416A075100C	4	75	100	16,0	10,00	50
6117080	EVM50L0416A100180C	4	100	180	16,0	10,00	50
6117094	EVM50L0416A180250C	4	180	250	16,0	10,00	50
6117098	EVM50L0416A250350C	4	250	350	16,0	10,00	50
6117102	EVM50L0416A350999C	4	350	999	16,0	10,00	50
6079499	EVM50L0426A100180C	4	100	180	26,0	10,00	50
6079500	EVM50L0426A180250C	4	180	250	26,0	10,00	50
6079501	EVM50L0426A250350C	4	250	350	26,0	10,00	50

(continued)



(Modular Inboard Face Grooving Blade with Coolant — continued)

Grooving and Cut-Off

order number	catalogue number	seat size	D min	D max	CD	FS	blade size
6079502	EVM50L0426A350999C	4	350	999	26,0	10,00	50
6079503	EVM50L0520A050060C	5	50	60	20,0	9,50	50
6079504	EVM50L0520A060075C	5	60	75	20,0	9,50	50
6079505	EVM50L0520A075100C	5	75	100	20,0	9,50	50
6079506	EVM50L0520A100180C	5	100	180	20,0	9,50	50
6079507	EVM50L0520A180250C	5	180	250	20,0	9,50	50
6079508	EVM50L0520A250350C	5	250	350	20,0	9,50	50
6079509	EVM50L0520A350999C	5	350	999	20,0	9,50	50
6079234	EVM65L0620A060075C	6	60	75	20,0	9,88	65
6079235	EVM65L0620A075100C	6	75	100	20,0	9,88	65
6079236	EVM65L0620A100180C	6	100	180	20,0	9,88	65
6079237	EVM65L0620A180250C	6	180	250	20,0	9,88	65
6079238	EVM65L0620A250350C	6	250	350	20,0	9,88	65
6079239	EVM65L0620A350999C	6	350	999	20,0	9,88	65
6079240	EVM65L0820A080180C	8	80	180	20,0	9,00	65
6079241	EVM65L0820A180999C	8	180	999	20,0	9,00	65

NOTE: Through the pocket coolant available in seat sizes 3 and higher.

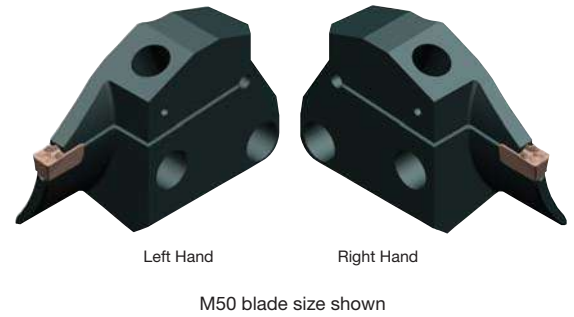
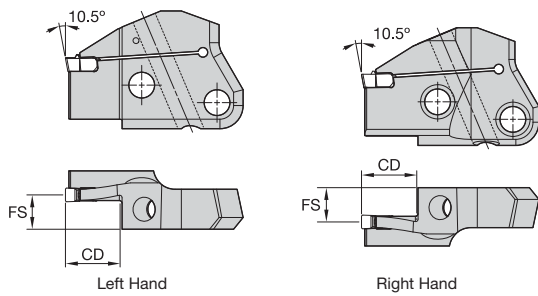
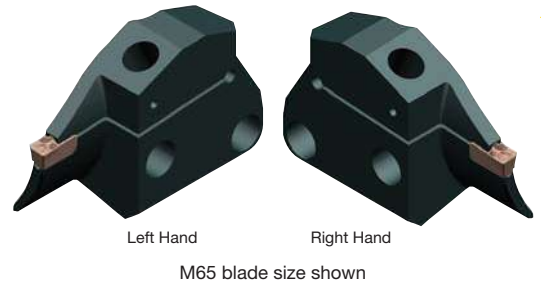
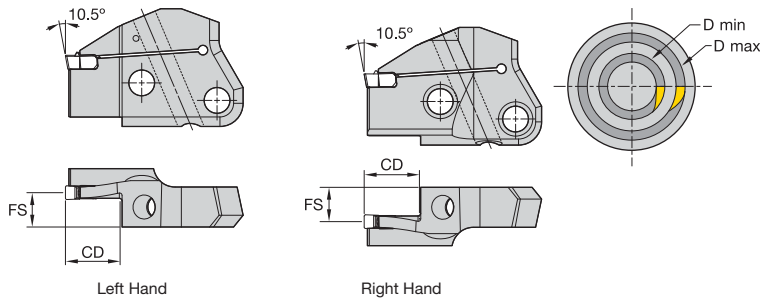
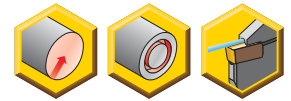

Grooving and Cut-Off

### Modular Outboard Face Grooving Blade with Coolant

order number	catalogue number	seat size	D min	D max	CD	FS	blade size
<b>right hand</b>							
6079340	EVM50R0312B035040C	3	35	40	12,0	10,50	50
6079411	EVM50R0312B040050C	3	40	50	12,0	10,50	50
6079412	EVM50R0312B050060C	3	50	60	12,0	10,50	50
6079413	EVM50R0312B060075C	3	60	75	12,0	10,50	50
6117061	EVM50R0312B075100C	3	75	100	12,0	10,50	50
6117065	EVM50R0312B100180C	3	100	180	12,0	10,50	50
6117069	EVM50R0312B180250C	3	180	250	12,0	10,50	50
6117073	EVM50R0312B250350C	3	250	350	12,0	10,50	50
6117077	EVM50R0312B350999C	3	350	999	12,0	10,50	50
6079414	EVM50R0320B075100C	3	75	100	20,0	10,50	50
6079415	EVM50R0320B100180C	3	100	180	20,0	10,50	50
6079416	EVM50R0320B180250C	3	180	250	20,0	10,50	50
6079417	EVM50R0320B250350C	3	250	350	20,0	10,50	50
6079418	EVM50R0320B350999C	3	350	999	20,0	10,50	50
6079429	EVM50R0416B040050C	4	40	50	16,0	10,00	50
6079430	EVM50R0416B050060C	4	50	60	16,0	10,00	50
6079451	EVM50R0416B060075C	4	60	75	16,0	10,00	50
6079452	EVM50R0416B075100C	4	75	100	16,0	10,00	50
6117091	EVM50R0416B100180C	4	100	180	16,0	10,00	50
6117095	EVM50R0416B180250C	4	180	250	16,0	10,00	50
6117099	EVM50R0416B250350C	4	250	350	16,0	10,00	50
6117103	EVM50R0416B350999C	4	350	999	16,0	10,00	50
6079453	EVM50R0426B100180C	4	100	180	26,0	10,00	50

(continued)



(Modular Outboard Face Grooving Blade with Coolant — continued)

Grooving and Cut-Off

order number	catalogue number	seat size	D min	D max	CD	FS	blade size
6079454	EVM50R0426B180250C	4	180	250	26,0	10,00	50
6079455	EVM50R0426B250350C	4	250	350	26,0	10,00	50
6079456	EVM50R0426B350999C	4	350	999	26,0	10,00	50
6079457	EVM50R0520B050060C	5	50	60	20,0	9,50	50
6079458	EVM50R0520B060075C	5	60	75	20,0	9,50	50
6079459	EVM50R0520B075100C	5	75	100	20,0	9,50	50
6079460	EVM50R0520B100180C	5	100	180	20,0	9,50	50
6079461	EVM50R0520B180250C	5	180	250	20,0	9,50	50
6079462	EVM50R0520B250350C	5	250	350	20,0	9,50	50
6079463	EVM50R0520B350999C	5	350	999	20,0	9,50	50
6079246	EVM65R0620B060075C	6	60	75	20,0	9,88	65
6079247	EVM65R0620B075100C	6	75	100	20,0	9,88	65
6079248	EVM65R0620B100180C	6	100	180	20,0	9,88	65
6079249	EVM65R0620B180250C	6	180	250	20,0	9,88	65
6079250	EVM65R0620B250350C	6	250	350	20,0	9,88	65
6079261	EVM65R0620B350999C	6	350	999	20,0	9,88	65
6079262	EVM65R0820B080180C	8	80	180	20,0	9,00	65
6079263	EVM65R0820B180999C	8	180	999	20,0	9,00	65
<b>left hand</b>							
6079420	EVM50L0312B035040C	3	35	40	12,0	10,50	50
6079421	EVM50L0312B040050C	3	40	50	12,0	10,50	50
6079422	EVM50L0312B050060C	3	50	60	12,0	10,50	50
6079423	EVM50L0312B060075C	3	60	75	12,0	10,50	50
6117062	EVM50L0312B075100C	3	75	100	12,0	10,50	50
6117066	EVM50L0312B100180C	3	100	180	12,0	10,50	50
6117070	EVM50L0312B180250C	3	180	250	12,0	10,50	50
6117074	EVM50L0312B250350C	3	250	350	12,0	10,50	50
6117078	EVM50L0312B350999C	3	350	999	12,0	10,50	50
6079424	EVM50L0320B075100C	3	75	100	20,0	10,50	50
6079425	EVM50L0320B100180C	3	100	180	20,0	10,50	50
6079426	EVM50L0320B180250C	3	180	250	20,0	10,50	50
6079427	EVM50L0320B250350C	3	250	350	20,0	10,50	50
6079428	EVM50L0320B350999C	3	350	999	20,0	10,50	50
6079464	EVM50L0416B040050C	4	40	50	16,0	10,00	50
6079465	EVM50L0416B050060C	4	50	60	16,0	10,00	50
6079466	EVM50L0416B060075C	4	60	75	16,0	10,00	50
6079467	EVM50L0416B075100C	4	75	100	16,0	10,00	50
6117092	EVM50L0416B100180C	4	100	180	16,0	10,00	50
6117096	EVM50L0416B180250C	4	180	250	16,0	10,00	50
6117100	EVM50L0416B250350C	4	250	350	16,0	10,00	50
6117104	EVM50L0416B350999C	4	350	999	16,0	10,00	50
6079468	EVM50L0426B100180C	4	100	180	26,0	10,00	50
6079469	EVM50L0426B180250C	4	180	250	26,0	10,00	50
6079470	EVM50L0426B250350C	4	250	350	26,0	10,00	50

(continued)

(Modular Outboard Face Grooving Blade with Coolant — continued)

order number	catalogue number	seat size	D min	D max	CD	FS	blade size
6079471	EVM50L0426B350999C	4	350	999	26,0	10,00	50
6079472	EVM50L0520B050060C	5	50	60	20,0	9,50	50
6079473	EVM50L0520B060075C	5	60	75	20,0	9,50	50
6079474	EVM50L0520B075100C	5	75	100	20,0	9,50	50
6079475	EVM50L0520B100180C	5	100	180	20,0	9,50	50
6079476	EVM50L0520B180250C	5	180	250	20,0	9,50	50
6079477	EVM50L0520B250350C	5	250	350	20,0	9,50	50
6079478	EVM50L0520B350999C	5	350	999	20,0	9,50	50
6079266	EVM65L0620B060075C	6	60	75	20,0	9,88	65
6079267	EVM65L0620B075100C	6	75	100	20,0	9,88	65
6079268	EVM65L0620B100180C	6	100	180	20,0	9,88	65
6079269	EVM65L0620B180250C	6	180	250	20,0	9,88	65
6079270	EVM65L0620B250350C	6	250	350	20,0	9,87	65
6079271	EVM65L0620B350999C	6	350	999	20,0	9,88	65
6079272	EVM65L0820B080180C	8	80	180	20,0	9,00	65
6079273	EVM65L0820B180999C	8	180	999	20,0	9,00	65

NOTE: Through the pocket coolant available in seat sizes 3 and higher.



- Interchangeable blades for versatility and depth of cut.
- Through the pocket coolant capable.

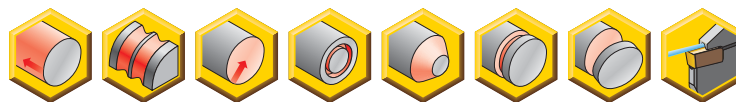

Grooving and Cut-Off

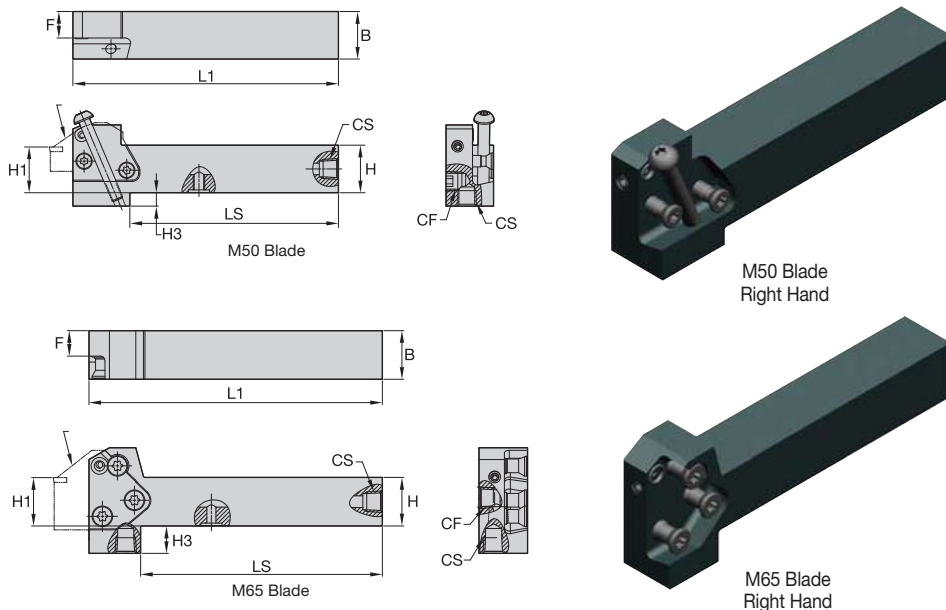

## ■ Modular Straight Toolholder with Coolant • Metric



order number	catalogue number	B	H	H1	L1	F	CS	CF	LS	H3	blade size	blade screw	Torx	clamping screw	Torx
<b>right hand</b>															
5979190	KGMSR2525M50C	25	25	25	138,75	13,84	G 1/8	G 1/8	109,00	7,00	50	MS1162	T25	MS2002	T25
5979745	KGMSR2525M65C	25	25	25	150,00	13,00	G 1/8	G 1/8	122,00	14,00	65	MS1163	T30	—	—
5979746	KGMSR3232P50C	32	32	32	158,75	20,81	G 1/8	G 1/8	133,62	—	50	MS1162	T25	MS2002	T25
5979747	KGMSR3232P65C	32	32	32	170,00	20,00	G 1/8	G 1/8	138,50	7,00	65	MS1163	T30	—	—
<b>left hand</b>															
5979191	KGMSL2525M50C	25	25	25	138,75	13,84	G 1/8	G 1/8	109,00	7,00	50	MS1162	T25	MS2002	T25
5979748	KGMSL2525M65C	25	25	25	150,00	13,00	G 1/8	G 1/8	122,00	14,00	65	MS1163	T30	—	—
5979749	KGMSL3232P50C	32	32	32	158,75	20,80	G 1/8	G 1/8	133,62	—	50	MS1162	T25	MS2002	T25
5979750	KGMSL3232P65C	32	32	32	170,00	20,00	G 1/8	G 1/8	142,00	7,00	65	MS1163	T30	—	—

NOTE: KGMS.: Right-hand holder uses right-hand blades.  
 KGME.: Right-hand holder uses left-hand blades.  
 M50 blade and clamp screw torque equals 8–10 Nm (71–88 in. lbs.).  
 M65 blade and clamp screw torque equals 18–20 Nm (159–177 in. lbs.).

screw catalogue number	screw order number	torque		thread	socket	wrench catalogue number	wrench order number
		Nm	in. lbs.				
MS1160	1099645	7	62	M5	T20	KT20	1022703
MS1162	1127019	9	80	M6	T25	KT25	1022725
MS1163	1124104	18	159	M8	T30	KT30L	1099676
MS1273	1020977	4	35.4	M4	T15	KT15	1022701
MS1490	2263299	17	151	M8	T45	KT45	1018227
MS1595	1094300	12	106	M6	T30	KT30	1099676
MS1970	1106668	12	106	M6	T30	KT30	1099676
MS2002	1621087	9	80	M6	T25	KT25	1022725
MS2091	1931147	9	80	M5	25IP	K25IP	2050113

- Interchangeable blades for versatility and depth of cut.
- Through the pocket coolant capable.

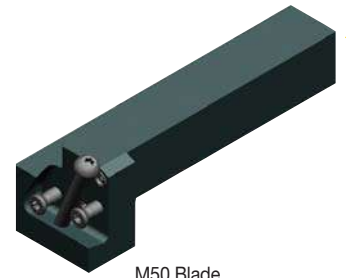
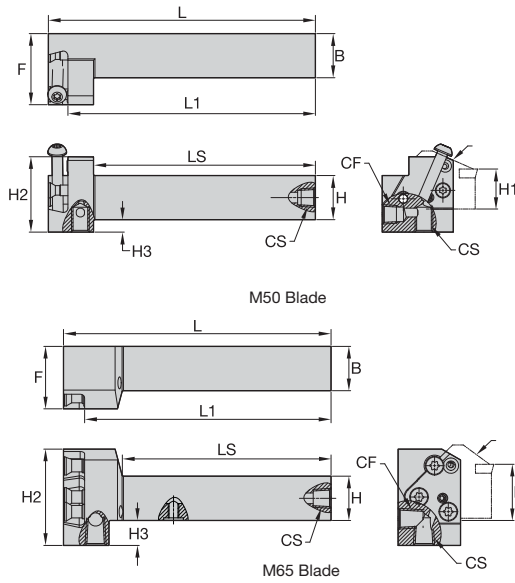
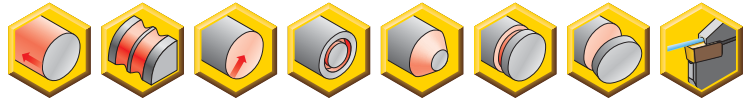

M50 Blade Right Hand

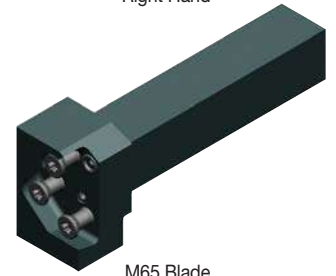

M65 Blade Right Hand

Grooving and Cut-Off

■ Modular End Mount Toolholder with Coolant • Metric



order number	catalogue number	B	H	H1	L1	F	CS	CF	LS	H3	blade size	blade screw	Torx	clamping screw	Torx
<b>right hand</b>															
5979765	KGMER2525M65C	25	25	25	138,15	35,00	G 1/8	G 1/8	117,00	14,00	65	MS1163	T30	—	—
5979192	KGMER2525M50C	25	25	25	139,25	40,00	G 1/8	G 1/8	124,85	7,00	50	MS1162	T25	MS2002	T25
5979767	KGMER3232P65C	32	32	32	158,15	35,00	G 1/8	G 1/8	137,00	7,00	65	MS1163	T30	—	—
5979766	KGMER3232P50C	32	32	32	159,25	40,00	G 1/8	G 1/8	145,25	—	50	MS1162	T25	MS2002	T25
<b>left hand</b>															
5979768	KGME2525M65C	25	25	25	138,15	35,00	G 1/8	G 1/8	117,00	14,00	65	MS1163	T30	—	—
5979193	KGME2525M50C	25	25	25	139,25	40,00	G 1/8	G 1/8	124,85	7,00	50	MS1162	T25	MS2002	T25
5979770	KGME3232P65C	32	32	32	158,15	35,00	G 1/8	G 1/8	137,00	7,00	65	MS1163	T30	—	—
5979769	KGME3232P50C	32	32	32	159,25	40,00	G 1/8	G 1/8	145,25	—	50	MS1162	T25	MS2002	T25

NOTE: KGMS... Right-hand holder uses right-hand blades.  
 KGME... Right-hand holder uses left-hand blades.  
 M50 blade and clamp screw torque equals 8–10 Nm (71–88 in. lbs.).  
 M65 blade and clamp screw torque equals 18–20 Nm (159–177 in. lbs.).

screw catalogue number	screw order number	torque		thread	socket	wrench catalogue number	wrench order number
		Nm	in. lbs.				
MS1160	1099645	7	62	M5	T20	KT20	1022703
MS1162	1127019	9	80	M6	T25	KT25	1022725
MS1163	1124104	18	159	M8	T30	KT30L	1099676
MS1273	1020977	4	35.4	M4	T15	KT15	1022701
MS1490	2263299	17	151	M8	T45	KT45	1018227
MS1595	1094300	12	106	M6	T30	KT30	1099676
MS1970	1106668	12	106	M6	T30	KT30	1099676
MS2002	1621087	9	80	M6	T25	KT25	1022725
MS2091	1931147	9	80	M5	25IP	K25IP	2050113

- Best-in-class KM Quick-Change platform.
- Through the pocket coolant capable.
- Interchangeable blades for versatility and depth of cut.

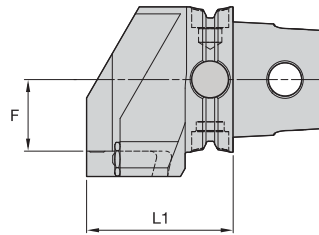
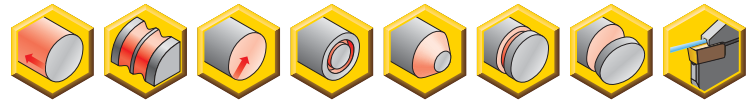

Right Hand



### ■ Modular Straight KM System with Coolant



order number	catalogue number	CSMS system size	L1	F	blade size	blade screw	Torx	clamp screw	Torx
<b>right hand</b>									
5999790	KM40TSKGMSR50C	KM40TS	53,5	15,0	50	MS1162	T25	MS2002	T25
6000422	KM50TSKGMSR65C	KM50TS	53,5	22,0	65	MS1163	T30	—	—
5999864	KM50TSKGMSR50C	KM50TS	58,5	23,0	50	MS1162	T25	MS2002	T25
6000431	KM63TSKGMSR65C	KM63TS	58,5	30,0	65	MS1163	T30	—	—
5999948	KM63TSKGMSR50C	KM63TS	63,5	31,0	50	MS1162	T25	MS2002	T25
5999972	KM63XMZKGMSR50CY	KM63XMZ	63,5	31,0	50	MS1162	T25	MS2002	T25
6017695	KM80TSKGMSR65C	KM80TS	63,5	40,0	65	MS1163	T30	—	—
6000018	KM80ATCKGMSR50C	KM80ATC	66,5	41,0	50	MS1162	T25	MS2002	T25
6000014	KM80TSKGMSR50C	KM80TS	66,5	41,0	50	MS1162	T25	MS2002	T25
<b>left hand</b>									
5999861	KM40TSKGMSL50C	KM40TS	53,5	15,0	50	MS1162	T25	MS2002	T25
6000424	KM50TSKGMSL65C	KM50TS	53,5	22,0	65	MS1163	T30	—	—
5999865	KM50TSKGMSL50C	KM50TS	58,5	23,0	50	MS1162	T25	MS2002	T25
6000433	KM63TSKGMSL65C	KM63TS	58,5	30,0	65	MS1163	T30	—	—
5999949	KM63TSKGMSL50C	KM63TS	63,5	31,0	50	MS1162	T25	MS2002	T25
5999973	KM63XMZKGMSLF50CY	KM63XMZ	63,5	31,0	50	MS1162	T25	MS2002	T25
6017696	KM80TSKGMSL65C	KM80TS	63,5	40,0	65	MS1163	T30	—	—
6000019	KM80ATCKGMSL50C	KM80ATC	66,5	41,0	50	MS1162	T25	MS2002	T25
6000015	KM80TSKGMSL50C	KM80TS	66,5	41,0	50	MS1162	T25	MS2002	T25

NOTE: KGMS... Right-hand holder uses right-hand blades.  
 KGME... Right-hand holder uses left-hand blades.  
 M50 blade and clamp screw torque equals 8–10 Nm (71–88 in. lbs.).  
 M65 blade and clamp screw torque equals 18–20 Nm (159–177 in. lbs.).

- Best-in-class KM Quick-Change platform.
- Through the pocket coolant capable.
- Interchangeable blades for versatility and depth of cut.

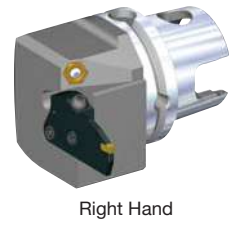
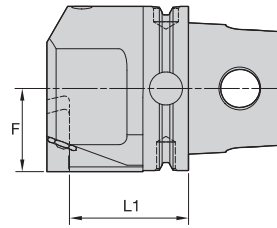

Right Hand



■ Modular End Mount KM System with Coolant • Metric



order number	catalogue number	CSMS system size	L1	F	blade size	blade screw	Torx	clamp screw	Torx
<b>right hand</b>									
5999788	KM40TSKGMER50C	KM40TS	28,0	20,50	50	MS1162	T25	MS2002	T25
5999862	KM50TSKGMER50C	KM50TS	38,0	25,50	50	MS1162	T25	MS2002	T25
6000410	KM50TSKGMER65C	KM50TS	47,0	25,50	65	MS1163	T30	—	—
6000425	KM63TSKGMER65C	KM63TS	47,0	32,52	65	MS1163	T30	—	—
5999946	KM63TSKGMER50C	KM63TS	48,0	32,50	50	MS1162	T25	MS2002	T25
6000434	KM63XMZKGMER65CY	KM63XMZ	47,0	32,50	65	MS1163	T30	—	—
5999950	KM63XMZKGMER50CY	KM63XMZ	48,0	32,50	50	MS1162	T25	MS2002	T25
6017697	KM80ATCKGMER65C	KM80ATC	57,0	40,50	65	MS1163	T30	—	—
6000016	KM80ATCKGMER50C	KM80ATC	58,0	40,50	50	MS1162	T25	MS2002	T25
6017693	KM80TSKGMER65C	KM80TS	57,0	40,50	65	MS1163	T30	—	—
6000012	KM80TSKGMER50C	KM80TS	58,0	40,50	50	MS1162	T25	MS2002	T25
<b>left hand</b>									
5999789	KM40TSKGMEL50C	KM40TS	28,0	20,50	50	MS1162	T25	MS2002	T25
5999863	KM50TSKGMEL50C	KM50TS	38,0	25,50	50	MS1162	T25	MS2002	T25
6000421	KM50TSKGMEL65C	KM50TS	47,0	25,50	65	MS1163	T30	—	—
6000430	KM63TSKGMEL65C	KM63TS	47,0	32,52	65	MS1163	T30	—	—
5999947	KM63TSKGMEL50C	KM63TS	48,0	32,50	50	MS1162	T25	MS2002	T25
6000436	KM63XMZKGMELF65CY	KM63XMZ	47,0	32,50	65	MS1163	T30	—	—
5999971	KM63XMZKGMELF50CY	KM63XMZ	48,0	32,50	50	MS1162	T25	MS2002	T25
6017698	KM80ATCKGMEL65C	KM80ATC	57,0	40,50	65	MS1163	T30	—	—
6000017	KM80ATCKGMEL50C	KM80ATC	58,0	40,50	50	MS1162	T25	MS2002	T25
6017694	KM80TSKGMEL65C	KM80TS	57,0	40,50	65	MS1163	T30	—	—
6000013	KM80TSKGMEL50C	KM80TS	58,0	40,50	50	MS1162	T25	MS2002	T25

NOTE: KGMS.: Right-hand holder uses right-hand blades.  
 KGME.: Right-hand holder uses left-hand blades.  
 M50 blade and clamp screw torque equals 8–10 Nm (71–88 in. lbs.).  
 M65 blade and clamp screw torque equals 18–20 Nm (159–177 in. lbs.).

- Through the pocket coolant capable.
- Interchangeable blades for versatility and depth of cut.

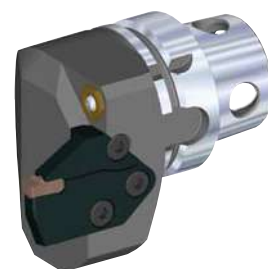
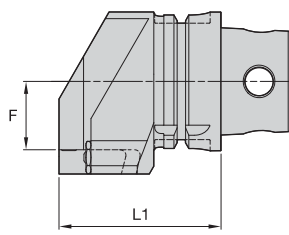
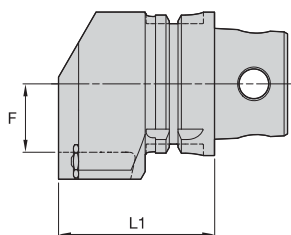
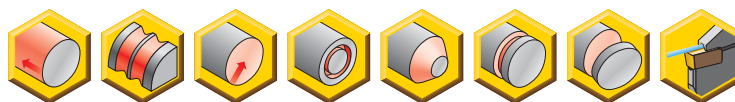

Right Hand

### ■ Modular Straight KM4X™ System with Coolant



order number	catalogue number	CSMS system size	L1	F	blade size	blade screw	Torx	clamp screw	Torx
<b>right hand</b>									
5543560	KM4X63KGMSR65C	KM4X63	68,5	30,0	65	MS1163	T30	—	—
6000407	KM4X63KGMSR50C	KM4X63	73,5	31,0	50	MS1162	T25	MS2002	T25
<b>left hand</b>									
5543558	KM4X63KGMSL65C	KM4X63	68,5	30,0	65	MS1163	T30	—	—
6000408	KM4X63KGMSL50C	KM4X63	73,5	31,0	50	MS1162	T25	MS2002	T25

NOTE: KGMS... Right-hand holder uses right-hand blades.  
 KGME... Right-hand holder uses left-hand blades.  
 M50 blade and clamp screw torque equals 8–10 Nm (71–88 in. lbs.).  
 M65 blade and clamp screw torque equals 18–20 Nm (159–177 in. lbs.).

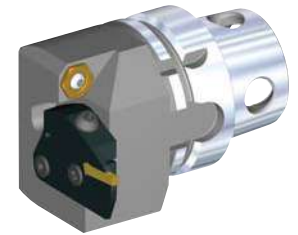
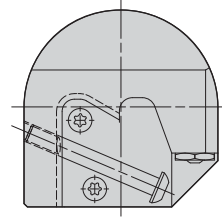
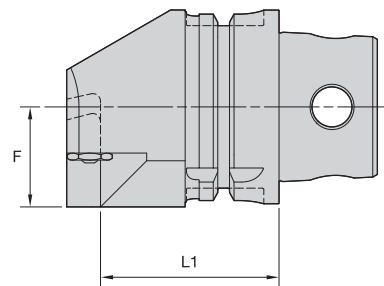

Right Hand

Grooving and Cut-Off

■ Modular End Mount KM4X™ System with Coolant

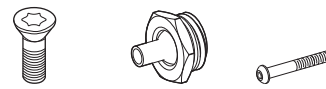

order number	catalogue number	CSMS system size			cartridge size	blade screw	nozzle	clamp screw	kg	lbs
		system size	L1	F						
<b>right hand</b>										
5543555	KM4X63KGMER65C	KM4X63	57,0	32,5	65	MS1163	PMT04525	—	1,87	4.13
6000404	KM4X63KGMER50C	KM4X63	58,0	32,5	50	MS1162	PMT04525	MS2002	1,85	4.08
6000407	KM4X63KGMSR50C	KM4X63	73,5	31,0	50	MS1162	PMT04525	MS2002	1,86	4.11
<b>left hand</b>										
5543553	KM4X63KGMEL65C	KM4X63	57,0	32,5	65	MS1163	PMT04525	—	1,87	4.13
6000405	KM4X63KGMEL50C	KM4X63	58,0	32,5	50	MS1162	PMT04525	MS2002	1,85	4.08
6000408	KM4X63KGMSL50C	KM4X63	73,5	31,0	50	MS1162	PMT04525	MS2002	1,86	4.11



- Standard PSC Quick-Change platform.
- Through the pocket coolant capable.
- Interchangeable blades for versatility and depth of cut.

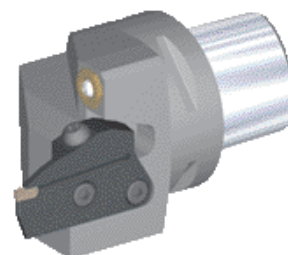
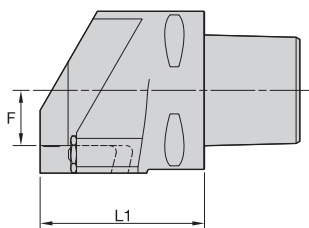
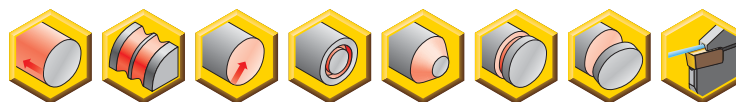

Right Hand

## ■ Modular Straight PSC System with Coolant



order number	catalogue number	CSMS system size	L1	F	blade size	blade screw	Torx	clamp screw	Torx
<b>right hand</b>									
6000028	PSC40KGMSR50C	PSC40	63,5	10,0	50	MS1162	T25	MS2002	T25
5405654	PSC50KGMSR65C	PSC50	49,0	25,5	65	MS1163	T30	—	—
6000152	PSC50KGMSR50C	PSC50	63,5	15,0	50	MS1162	T25	MS2002	T25
6000464	PSC63KGMSR65C	PSC63	60,5	21,0	65	MS1163	T30	—	—
6000211	PSC63KGMSR50C	PSC63	65,5	22,0	50	MS1162	T25	MS2002	T25
6000468	PSC80KGMSR65C	PSC80	68,5	29,0	65	MS1163	T30	—	—
6000216	PSC80KGMSR50C	PSC80	73,5	30,0	50	MS1162	T25	MS2002	T25
<b>left hand</b>									
6000029	PSC40KGMSL50C	PSC40	63,5	10,0	50	MS1162	T25	MS2002	T25
5405655	PSC50KGMSL65C	PSC50	49,0	25,5	65	MS1163	T30	—	—
6000153	PSC50KGMSL50C	PSC50	63,5	15,0	50	MS1162	T25	MS2002	T25
6000465	PSC63KGMSL65C	PSC63	60,5	21,0	65	MS1163	T30	—	—
6000213	PSC63KGMSL50C	PSC63	65,5	22,0	50	MS1162	T25	MS2002	T25
6000469	PSC80KGMSL65C	PSC80	68,5	29,0	65	MS1163	T30	—	—
6000217	PSC80KGMSL50C	PSC80	73,5	30,0	50	MS1162	T25	MS2002	T25

- Standard PSC Quick-Change platform.
- Through the pocket coolant capable.
- Interchangeable blades for versatility and depth of cut.

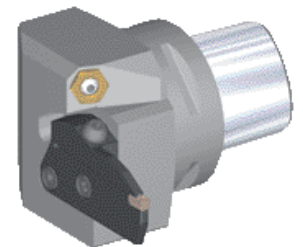
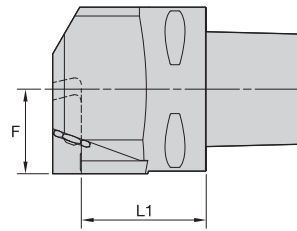
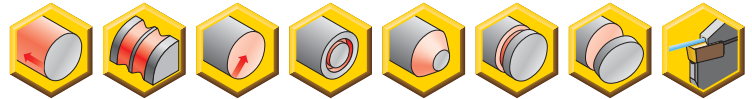

Right Hand

Grooving and Cut-Off

■ Modular End Mount PSC System with Coolant



order number	catalogue number	CSMS system size	L1	F	blade size	blade screw	Torx	clamp screw	Torx
<b>right hand</b>									
6000026	PSC40KGMER50C	PSC40	33,0	20,5	50	MS1162	T25	MS2002	T25
6000030	PSC50KGMER50C	PSC50	43,0	25,5	50	MS1162	T25	MS2002	T25
5405652	PSC50KGMER65C	PSC50	55,5	22,0	65	MS1163	T30	—	—
6000159	PSC63KGMER50C	PSC63	48,0	32,5	50	MS1162	T25	MS2002	T25
6000462	PSC63KGMER65C	PSC63	49,0	32,5	65	MS1163	T30	—	—
6000466	PSC80KGMER65C	PSC80	57,0	40,5	65	MS1163	T30	—	—
6000214	PSC80KGMER50C	PSC80	58,0	40,5	50	MS1162	T25	MS2002	T25
<b>left hand</b>									
6000027	PSC40KGME50C	PSC40	33,0	20,5	50	MS1162	T25	MS2002	T25
6000151	PSC50KGME50C	PSC50	43,0	25,5	50	MS1162	T25	MS2002	T25
5405653	PSC50KGME65C	PSC50	55,5	22,0	65	MS1163	T30	—	—
6000160	PSC63KGME50C	PSC63	48,0	32,5	50	MS1162	T25	MS2002	T25
6000463	PSC63KGME65C	PSC63	49,0	32,5	65	MS1163	T30	—	—
6000467	PSC80KGME65C	PSC80	57,0	40,5	65	MS1163	T30	—	—
6000215	PSC80KGME50C	PSC80	58,0	40,5	50	MS1162	T25	MS2002	T25

# ➤ VDI Toolholders

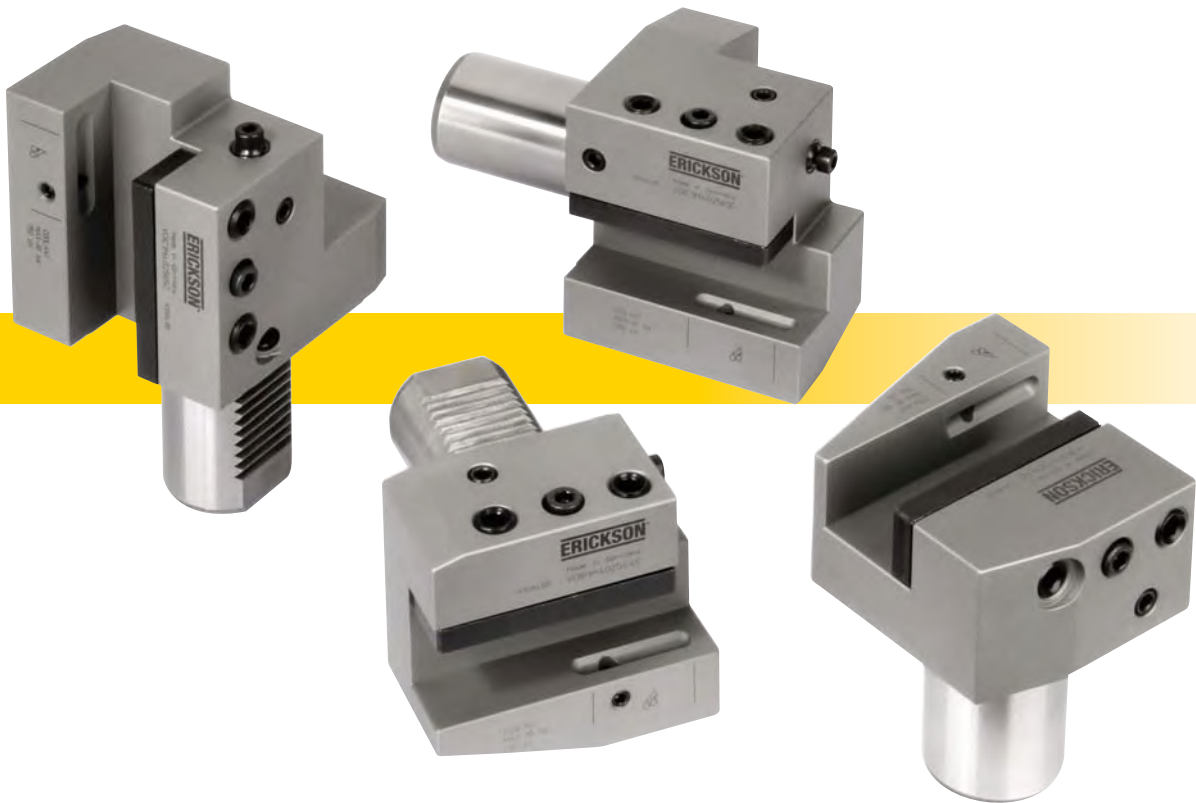

- VDI adaptor with coolant support for square shank toolholder.
- ISO 10889.

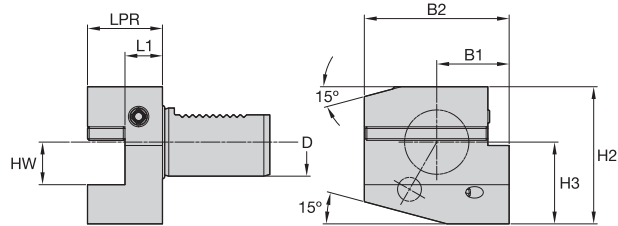

Grooving and Cut-Off

■ VDI Form B1 • HPC • Right Hand Short • Metric

order number	catalogue number	D	B2	B1	HW	H2	H3	L1	LPR
6151491	VDIB1M302040C	30,00	70,00	35,00	20,00	66,00	38,00	22,00	40,00
6151492	VDIB1M402544C	40,00	85,00	42,50	25,00	80,50	48,00	22,00	44,00

VDI Form B2 • Left Hand Short

- VDI adaptor with coolant support for square shank toolholder.
- ISO 10889.

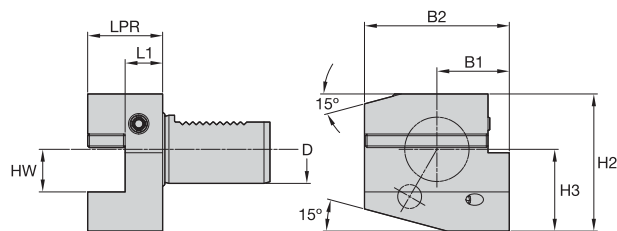

Artwork shows right hand tool.  
Left hand tool mirror inverted.

■ VDI Form B2 • HPC • Left Hand Short • Metric

order number	catalogue number	D	B2	B1	HW	H2	H3	L1	LPR
6151493	VDIB2M302040C	30,00	70,00	35,00	20,00	66,00	38,00	22,00	40,00
6151494	VDIB2M402544C	40,00	85,00	42,50	25,00	80,50	48,00	22,00	44,00

- VDI adaptor with coolant support for square shank toolholder.
- ISO 10889.

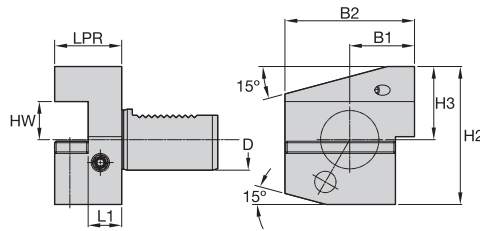

Grooving and Cut-Off

■ VDI Form B3 • HPC • Right Hand Short Inverted • Metric

order number	catalogue number	D	B2	B1	HW	H2	H3	L1	LPR
6151495	VDIB3M302040C	30,00	70,00	35,00	20,00	73,00	38,00	22,00	40,00
6151497	VDIB3M402544C	40,00	85,00	42,50	25,00	90,50	48,00	22,00	44,00

VDI Form B4 • Left Hand Short Inverted

- VDI adaptor with coolant support for square shank toolholder.
- ISO 10889.

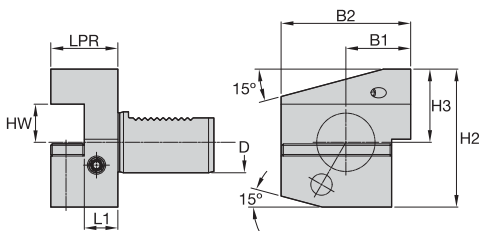

Artwork shows right hand tool.  
Left hand tool mirror inverted.

■ VDI Form B4 • HPC • Left Hand Short Inverted • Metric

order number	catalogue number	D	B2	B1	HW	H2	H3	L1	LPR
6151498	VDIB4M302040C	30,00	70,00	35,00	20,00	73,00	38,00	22,00	40,00
6151499	VDIB4M402544C	40,00	85,00	42,50	25,00	90,50	48,00	22,00	44,00

- VDI adaptor with coolant support for square shank toolholder.
- ISO 10889.

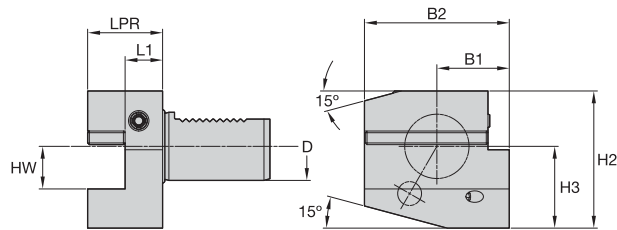

Grooving and Cut-Off

■ VDI Form B5 • HPC • Right Hand Long • Metric

order number	catalogue number	D	B2	B1	HW	H2	H3	L1	LPR
6151500	VDIB5M302040C	30,00	100,00	65,00	20,00	66,00	38,00	22,00	40,00
6151511	VDIB5M402544C	40,00	118,00	75,50	25,00	80,50	48,00	22,00	44,00

VDI Form B6 • Left Hand Long

- VDI adaptor with coolant support for square shank toolholder.
- ISO 10889.

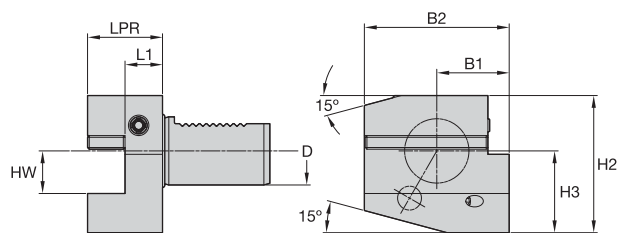

Artwork shows right hand tool.  
Left hand tool mirror inverted.

■ VDI Form B6 • HPC • Left Hand Long • Metric

order number	catalogue number	D	B2	B1	HW	H2	H3	L1	LPR
6151512	VDIB6M302040C	30,00	100,00	65,00	20,00	66,00	38,00	22,00	40,00
6151513	VDIB6M402544C	40,00	118,00	75,50	25,00	80,50	48,00	22,00	44,00

- VDI adaptor with coolant support for square shank toolholder.
- ISO 10889.

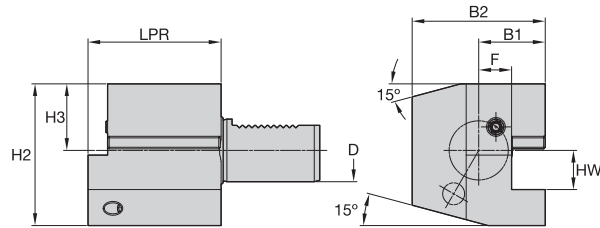

Grooving and Cut-Off

■ VDI Form C1 • HPC • Right Hand • Metric

order number	catalogue number	D	B2	B1	F	HW	H2	H3	LPR
6151514	VDIC1M302070C	30,00	70,00	35,00	17,00	20,00	66,00	38,00	70,00
6151515	VDIC1M402585C	40,00	85,00	42,50	21,00	25,00	80,50	48,00	85,00

VDI Form C2 • Left Hand

- VDI adaptor with coolant support for square shank toolholder.
- ISO 10889.

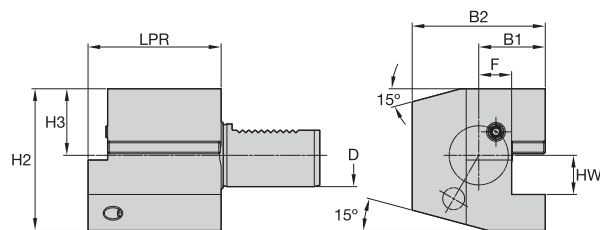

■ VDI Form C2 • HPC • Left Hand • Metric

Artwork shows right hand tool.  
Left hand tool mirror inverted.

order number	catalogue number	D	B2	B1	F	HW	H2	H3	LPR
6151516	VDIC2M302070C	30,00	76,00	41,00	23,00	20,00	66,00	38,00	70,00
6151517	VDIC2M402585C	40,00	90,00	47,50	25,50	25,00	80,50	48,00	85,00

- VDI adaptor with coolant support for square shank toolholder.
- ISO 10889.

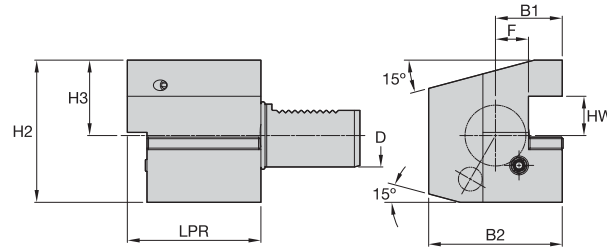

Grooving and Cut-Off

■ VDI Form C3 • HPC • Right Hand Inverted • Metric

order number	catalogue number	D	B2	B1	F	HW	H2	H3	LPR
6151518	VDIC3M302070C	30,00	70,00	35,00	17,00	20,00	73,00	38,00	70,00
6151519	VDIC3M402585C	40,00	85,00	42,50	21,00	25,00	90,50	48,00	85,00

VDI Form C4 • Left Hand Inverted

- VDI adaptor with coolant support for square shank toolholder.
- ISO 10889.

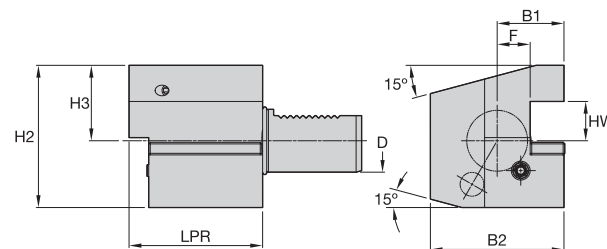

Artwork shows right hand tool.  
Left hand tool mirror inverted.

■ VDI Form C4 • HPC • Left Hand Inverted • Metric

order number	catalogue number	D	B2	B1	F	HW	H2	H3	LPR
6151520	VDIC4M302070C	30,00	70,00	35,00	17,00	20,00	73,00	38,00	70,00
6151521	VDIC4M402585C	40,00	85,00	42,50	21,00	25,00	90,50	48,00	85,00



■ Shank Specifications

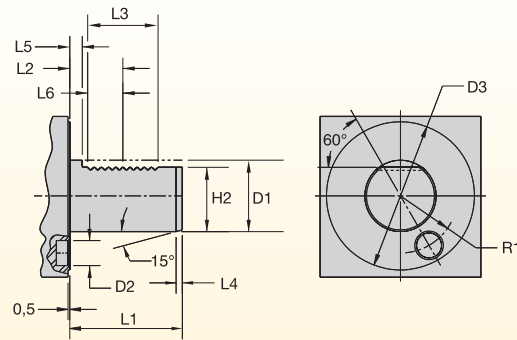

	D1	D2	D3	L1	L2	L3	L4	L5	L6	H2	R1
<b>30</b>	30,00	14,00	68,00	55,00	29,70	40,00	2,00	7,00	20,00	27,00	25,00
	1.181	0.551	2.677	2.165	1.169	1.575	0.079	0.276	0.787	1.063	0.984
<b>40</b>	40,00	14,00	83,00	63,00	29,70	40,00	3,00	7,00	20,00	36,00	32,00
	1.575	0.551	3.268	2.480	1.169	1.575	0.118	0.276	0.787	1.417	1.260
<b>50</b>	50,00	16,00	98,00	78,00	35,70	48,00	3,00	8,00	24,00	45,00	37,00
	1.969	0.630	3.858	3.071	1.406	1.890	0.118	0.315	0.945	1.772	1.457
<b>60</b>	60,00	16,00	123,00	94,00	43,70	56,00	4,00	10,00	28,00	55,00	48,00
	2.362	0.630	4.843	3.701	1.720	2.205	0.157	0.394	1.102	2.165	1.890

# A4™ Tooling and Beyond™ Inserts



Choose A4 tooling for turning, facing, grooving, face grooving, and cut-off applications across a broad range of workpiece materials. The unique clamping system and versatile insert geometry delivers a very high metal removal rate.

## FEATURES AND BENEFITS

### A4 Grooving and Turning System

- One tool for turning, facing, grooving, face-grooving, and cut-off in O.D. and I.D. applications means exceptionally fast cycle times, no turret indexes!
- Extra-long clamping area, ground 120° bottom prism seating surface, and an exclusive top guide rail combine to deliver unsurpassed grooving and side-turning stability!
- Precise insert positioning is ensured for accurate cuts!
- Rigid clamping securely locks insert in place through the toughest cuts.
- Versatile design enables one system to handle O.D. and I.D. grooving, face grooving, back turning, undercutting, and even threading operations.
- Chip control inserts provide excellent chip evacuation in grooving, and offer better chip control in multidirectional turning.

Experience the advantages at your Authorised Kennametal Distributor or at [kennametal.com](http://kennametal.com).



[kennametal.com](http://kennametal.com)



**beyond™ EVOLUTION™**

Connecting the tool to your machine is easy. Just select one of the two available hose packages, and Active Coolant Control will be keeping you cool in no time!

## ➤ Don't know exactly what you need?

To connect Beyond™ Evolution™ tooling to the industry's most common machines. The Kennametal universal coolant packs are ideal! Each pack contains the most common thread sizes with a variety of fitting styles for maximum flexibility.

### ■ Universal 200mm Coolant Pack

order number	catalogue number	quantity	description
6145372	COOL-KIT-101	1	1/16 NPTF male to 7/16 JIC male fitting
		1	1/8 NPTF male to 7/16 JIC male fitting
		1	G1/8 male to 7/16 JIC male fitting
		1	M10 x 1,5 male to 7/16 JIC male fitting
		2	Male JIC to Swivel Female JIC Elbow
		1	200mm Hose Female JIC to Female JIC

### ■ Universal 300mm Coolant Pack

order number	catalogue number	quantity	description
6145373	COOL-KIT-201	1	1/16 NPTF male to 7/16 JIC male fitting
		1	1/8 NPTF male to 7/16 JIC male fitting
		1	G1/8 male to 7/16 JIC male fitting
		1	M10 x 1,5 male to 7/16 JIC male fitting
		2	Male JIC to Swivel Female JIC Elbow
		1	300mm Hose Female JIC to Female JIC

## ➤ Know what you need?

Every component is individually available, including less common fittings.  
Knowing the precise components required will allow you to choose only the fittings you need!

### ■ Coolant Hose Accessories

order number	catalogue number	description
6145374	1-16NPTF-JIC	1/16 NPTF male to 7/16 JIC male fitting
6145375	1-8NPTF-JIC	1/8 NPTF male to 7/16 JIC male fitting
6145376	G18-JIC	G1/8 male to 7/16 JIC male fitting
6145377	M10-JIC	M10 x 1,5 male to 7/16 JIC male fitting
6145379	JICM-JICF-ELB	Male JIC to Swivel Female JIC Elbow
6145380	COOL-HOSE-200	200mm Female JIC to Female JIC
6145381	COOL-HOSE-300	300mm Female JIC to Female JIC
6145382	M6-JIC	M6 x 1,0 male to 7/16 JIC male fitting
6145378	M8-JIC	M8 x 1,25 male to 7/16 JIC male fitting
6145383	JICM-JICM-STR	7/16 JIC male to 7/16 JIC male adaptor
6145386	G14-G18-RED	Male G1/4 to Female G1/8 reducer
6432549	COOL-HOSE-200-FLEX	Universal 200mm Flex Coolant Hose
6432550	COOL-HOSE-300-FLEX	Universal 300mm Flex Coolant Hose



**Active Coolant Control Guidelines**

1. Beyond™ Evolution™ system capable of 350 bar (5076 psi).
2. Toolholder delivered with four entry holes.
3. A quality filtration system is necessary to prevent blockages in the toolholder that will effect coolant flow and performance.
4. Machines without a proper filtering system may require modification or an inline filter.
  - For pressure >70 bar [1015 psi], use 10–20 µm filter.
  - For pressure <70 bar [1015 psi], 50–100 µm.
  - Using fine filters in low-pressure applications may affect flow rate.

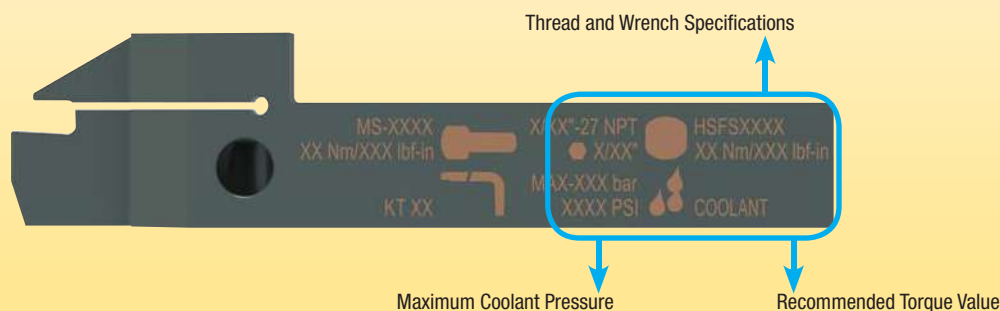
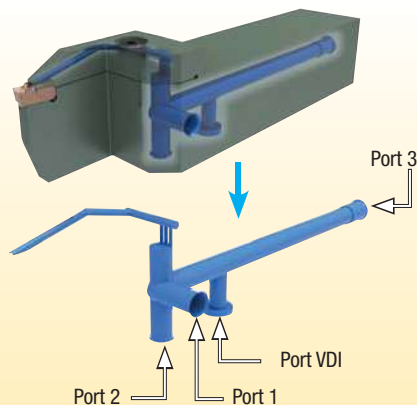

**General Safety Guidelines**

1. All safety doors and mechanisms must be in place before trying out the internal coolant to avoid any danger to the operator in the event of a failure.
2. Use the correct pipe fittings to connect the holders to the system. Ensure the maximum pressure recommended for the fittings are not exceeded.
3. While implementing pressure >80 bar [1160 psi], increase the pressure in steps to ensure proper functioning of insert clamping and leak-free joints.
4. While indexing inserts, ensure the pocket is free from chips and/or dirt. Also, inspect the insert and make sure there are no blockages in the coolant canal.
5. Periodically check all hoses and fittings for damage and wear for proper functioning of the system. This check should also include filters.

**Active Coolant Control Performance**

Internal coolant offers a clear advantage in tool life and chip forming/evacuation vs. external coolant in difficult conditions and in high-pressure coolant.  
*Example: Chipbreaking in plunging of steel.*

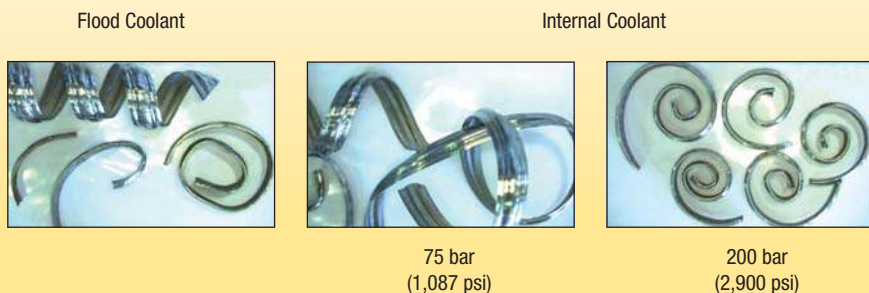

Material steel ST52;  
Insert size 6mm; f = 0,25 mm/U

**Low Pressure** — If performance is at risk due to low coolant pressure, apply internal coolant in combination with external coolant to increase volume.

**Recommendation to improve tool life and/or productivity:** Apply high pressure coolant: 80–350 bar recommended.

**VDI Assemblies**

The Beyond™ Evolution™ Active Coolant Control can be leveraged with VDI holding systems with both traditional or Quick-Change coolant connections.

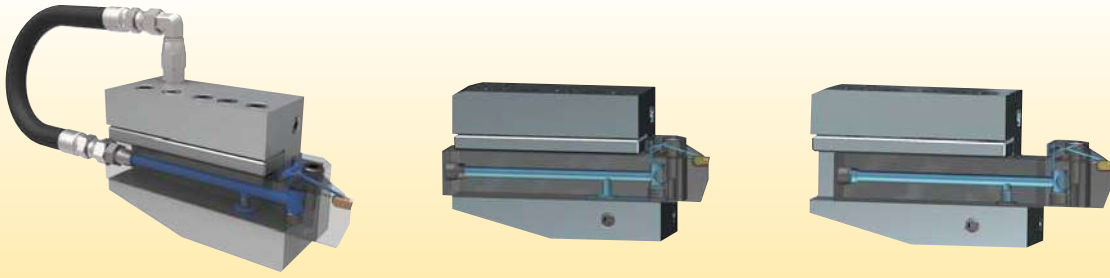

Coolant flow transfer from VDI adaptor to toolholder

A marker on the toolholder must remain within the coolant range indicated on the VDI system for uninterrupted coolant transfer.

### ■ Technical Details

**Pressure limit 80 bar.**

Nozzle set comes pre-assembled.  
For the holder application with internal coolant only nozzle can be plugged by M5 screw (delivered). Use Loc Tite light, medium strength, or thread sealant.

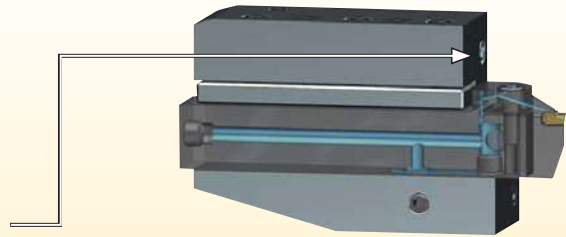

Holder	Slide Area	Max. Pressure	Torque (Pressure Screws)
VDI 30	22mm	80 bar	20 Nm
VDI 40	30mm	80 bar	35 Nm
<b>Spare sets</b>			
Nozzle		<b>PKG LAL 1205M</b>	
Set Pressure Screw, Pressure Plate, Spring		See separately for each type in BOM	

# ➤ A4™ Tooling and Beyond™ Inserts

For All Your O.D. and I.D. Applications

## Primary Application

Choose A4 tooling for turning, facing, grooving, face grooving, and cut-off applications across a broad range of workpiece materials. The unique clamping system and versatile insert geometry delivers a very high metal removal rate.

## Features and Benefits

### A4 Grooving and Turning System

- One tool for turning, facing, grooving, face-grooving, and cut-off in O.D. and I.D. applications means exceptionally fast cycle times, no turret indexes!
- Extra-long clamping area, ground 120° bottom prism seating surface, and an exclusive top guide rail combine to deliver unsurpassed grooving and side-turning stability!
- Precise insert positioning is ensured for accurate cuts!
- Rigid clamping securely locks insert in place through the toughest cuts.
- Versatile design enables one system to handle O.D. and I.D. grooving, face grooving, back turning, undercutting, and even threading operations.
- Chip control inserts provide excellent chip evacuation in grooving, and offer better chip control in multidirectional turning.

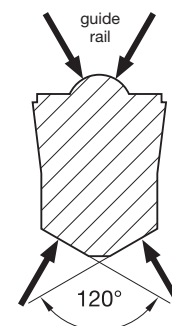

### A4 Chipbreakers



GMN Chipbreaker



GMP Chipbreaker



GMN Chipbreaker



GMP Chipbreaker



GUP Chipbreaker



### The A4™ System Increases Productivity

- Covers multiple applications.
- Reduces tool cost.
- Minimises machining time.





### ■ Step 1 • Select A4 size for grooving and turning application

#### What you need to know:

- Groove depth, width, and profile.
- Material being machined.
- Application to be performed (O.D. and I.D. grooving, turning, face grooving, and cut-off).

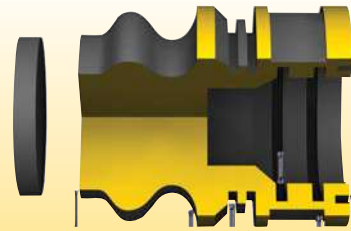

#### General Recommendation to Select the Insert Size

for workpiece diameters	insert seat size
<25mm	3
25–50mm	4
>50mm	5–10

### ■ Step 2 • Select chipbreaker style and feed rate

Based on the application and seat size, determine the recommended geometry and starting feed rate.

#### Plunge Feed Rates

first choice  
 alternate choice

Chip Control	Description	Insert Geometry	Seat Size	Corner Radius mm	Starting Conditions mm	Plunge Feed Rates mm/rev								
						0,05	0,10	0,15	0,20	0,25	0,30	0,35		
-GUP	<ul style="list-style-type: none"> <li>• Groove and turn inserts in new Beyond™ grades.</li> <li>• Available in moulded and precision-ground styles.</li> <li>• Positive rake angle with enhanced chip control.</li> <li>• Available in metric widths only.</li> </ul>		2	0,2	0,08	▶	▶	▶	▶	▶	▶	▶	▶	
			3	0,2	0,09	▶	▶	▶	▶	▶	▶	▶	▶	▶
			4	0,4	0,11	▶	▶	▶	▶	▶	▶	▶	▶	▶
			5	0,8	0,15	▶	▶	▶	▶	▶	▶	▶	▶	▶
			6	0,4	0,16	▶	▶	▶	▶	▶	▶	▶	▶	▶
			8	0,8	0,18	▶	▶	▶	▶	▶	▶	▶	▶	▶
			10	1,2	0,20	▶	▶	▶	▶	▶	▶	▶	▶	▶
			12	0,4	0,17	▶	▶	▶	▶	▶	▶	▶	▶	▶
			14	0,8	0,20	▶	▶	▶	▶	▶	▶	▶	▶	▶
			16	1,2	0,22	▶	▶	▶	▶	▶	▶	▶	▶	▶
-GMP	<ul style="list-style-type: none"> <li>• Groove and turn inserts.</li> <li>• Available in moulded and precision-ground styles.</li> <li>• Positive rake angle.</li> <li>• Available in metric widths only.</li> </ul>		2	0,2	0,08	▶	▶	▶	▶	▶	▶	▶	▶	
			3	0,2	0,09	▶	▶	▶	▶	▶	▶	▶	▶	▶
			4	0,4	0,11	▶	▶	▶	▶	▶	▶	▶	▶	▶
			5	0,8	0,15	▶	▶	▶	▶	▶	▶	▶	▶	▶
			6	0,4	0,16	▶	▶	▶	▶	▶	▶	▶	▶	▶
			8	0,8	0,18	▶	▶	▶	▶	▶	▶	▶	▶	▶
			10	1,2	0,20	▶	▶	▶	▶	▶	▶	▶	▶	▶
			12	0,4	0,17	▶	▶	▶	▶	▶	▶	▶	▶	▶
			14	0,8	0,20	▶	▶	▶	▶	▶	▶	▶	▶	▶
			16	1,2	0,22	▶	▶	▶	▶	▶	▶	▶	▶	▶
-GMN	<ul style="list-style-type: none"> <li>• Groove and turn moulded and precision-ground inserts.</li> <li>• Stable cutting edge.</li> <li>• Available in metric and inch widths.</li> </ul>		2	0,2	0,08	▶	▶	▶	▶	▶	▶	▶	▶	
			3	0,2	0,09	▶	▶	▶	▶	▶	▶	▶	▶	▶
			4	0,4	0,11	▶	▶	▶	▶	▶	▶	▶	▶	▶
			5	0,8	0,15	▶	▶	▶	▶	▶	▶	▶	▶	▶
			6	0,4	0,16	▶	▶	▶	▶	▶	▶	▶	▶	▶
			8	0,8	0,18	▶	▶	▶	▶	▶	▶	▶	▶	▶
			10	1,2	0,20	▶	▶	▶	▶	▶	▶	▶	▶	▶
			12	0,4	0,17	▶	▶	▶	▶	▶	▶	▶	▶	▶
			14	0,8	0,20	▶	▶	▶	▶	▶	▶	▶	▶	▶
			16	1,2	0,22	▶	▶	▶	▶	▶	▶	▶	▶	▶

#### Maximum Feed Rate Values

Data is for P and K material groups. Maximum feed rates should be adjusted by multiplying feed rates by following factors for other material groups.

Material Group	Feed Factor
M	.8
N	.8
S	.5
H	1.2

#### I.D. and Face Grooving

For I.D. and face grooving applications, reduce feed rate by 20%.

### ■ Step 3 • Select the starting speed

Based on material and grade, identify starting speed (vc).  
First choice is in **bold** type.

- A Based on material group and grade, identify starting speed (vc).
- B First choice starting speed is in **bold**.

Recommended Starting Speeds [m/min]																						
Material Group	K313			KCU10/KC5010			KCU25/KC5025			KCP10			KCP25			KCK20B			KY3500			
P	0-1	-	-	-	140	<b>280</b>	335	110	<b>225</b>	270	185	<b>400</b>	450	145	<b>290</b>	365	200	<b>440</b>	490	-	-	-
	2	-	-	-	140	<b>200</b>	245	110	<b>160</b>	195	185	<b>270</b>	360	145	<b>200</b>	305	200	<b>300</b>	380	-	-	-
	3	-	-	-	140	<b>155</b>	245	110	<b>125</b>	195	170	<b>190</b>	260	140	<b>155</b>	245	600	<b>200</b>	280	-	-	-
	4	-	-	-	75	<b>110</b>	170	60	<b>90</b>	135	90	<b>145</b>	200	75	<b>110</b>	180	100	<b>160</b>	220	-	-	-
	5	-	-	-	120	<b>200</b>	260	100	<b>160</b>	210	150	<b>220</b>	305	120	<b>200</b>	270	165	<b>240</b>	330	-	-	-
	6	-	-	-	110	<b>150</b>	230	85	<b>120</b>	185	120	<b>180</b>	275	110	<b>150</b>	230	130	<b>190</b>	300	-	-	-
M	1	60	<b>90</b>	120	140	<b>210</b>	260	90	<b>170</b>	245	-	-	-	-	-	-	-	-	-	-	-	-
	2	45	<b>75</b>	110	120	<b>200</b>	245	90	<b>150</b>	245	-	-	-	-	-	-	-	-	-	-	-	-
	3	35	<b>65</b>	100	120	<b>180</b>	245	90	<b>140</b>	210	-	-	-	-	-	-	-	-	-	-	-	-
K	1	30	<b>75</b>	120	120	<b>180</b>	245	100	<b>145</b>	195	170	<b>245</b>	440	140	<b>200</b>	360	210	<b>305</b>	550	180	<b>760</b>	1040
	2	25	<b>70</b>	110	90	<b>150</b>	210	70	<b>120</b>	170	120	<b>195</b>	340	100	<b>160</b>	280	150	<b>245</b>	430	275	<b>365</b>	500
	3	20	<b>60</b>	90	60	<b>110</b>	150	50	<b>85</b>	120	120	<b>170</b>	270	100	<b>140</b>	220	150	<b>210</b>	335	-	-	-
N	1-2	150	<b>370</b>	610	150	<b>550</b>	975	120	<b>440</b>	780	-	-	-	-	-	-	-	-	-	-	-	-
	3	-	-	-	-	-	-	-	-	-	-	-	-	-	-	-	-	-	-	-	-	-
	4	120	<b>275</b>	430	120	<b>365</b>	610	100	<b>290</b>	490	-	-	-	-	-	-	-	-	-	-	-	-
	5	45	<b>90</b>	150	90	<b>170</b>	245	70	<b>135</b>	195	-	-	-	-	-	-	-	-	-	-	-	-
	6	40	<b>75</b>	150	120	<b>210</b>	305	100	<b>170</b>	245	-	-	-	-	-	-	-	-	-	-	-	-
	7	40	<b>75</b>	150	120	<b>210</b>	305	100	<b>170</b>	245	-	-	-	-	-	-	-	-	-	-	-	-
S	1	8	<b>30</b>	75	15	<b>55</b>	135	8	<b>40</b>	60	-	-	-	-	-	-	-	-	-	-	-	-
	2	8	<b>35</b>	75	15	<b>60</b>	135	8	<b>30</b>	75	-	-	-	-	-	-	-	-	-	-	-	-
	3	8	<b>40</b>	75	15	<b>70</b>	135	15	<b>40</b>	75	-	-	-	-	-	-	-	-	-	-	-	-
	4	8	<b>45</b>	75	15	<b>70</b>	170	8	<b>50</b>	110	-	-	-	-	-	-	-	-	-	-	-	-
H	1	-	-	-	-	-	-	-	-	-	-	-	-	-	-	-	-	-	-	-	-	-
	2	-	-	-	-	-	-	-	-	-	-	-	-	-	-	-	-	-	-	-	-	-
	3	-	-	-	-	-	-	-	-	-	-	-	-	-	-	-	-	-	-	-	-	-
	4	-	-	-	-	-	-	-	-	-	-	-	-	-	-	-	-	-	-	-	-	-

### ■ Step 4 • Select toolholder based on application

Choose the high-performance holder based on your specific grooving or cut-off application, with the corresponding seat size.

	conventional toolholders	modular blades
O.D. Grooving, Cut-Off, and Turning	1st Choice	2nd Choice
Face Grooving	1st Choice	2nd Choice
I.D. Grooving, Cut-Off, and Turning	1st Choice	—

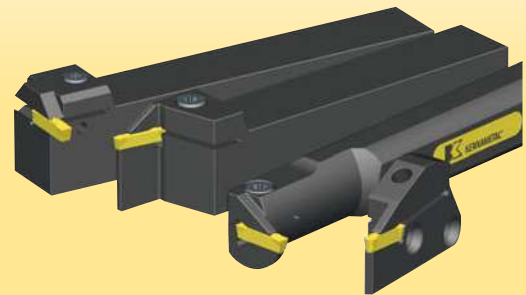

NOTE: Insert seat size must match the seat size of the toolholder.

### ■ Step 5 • Select the insert and holder from catalogue page

#### Congratulations!

You have successfully maximised your productivity by selecting the best insert geometry, grade, and cutting specifications for your application!

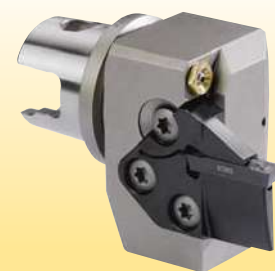

## How Do Catalogue Numbers Work?

Each character in our catalog number signifies a specific trait of that product. Use the following key columns and corresponding images to easily identify which attributes apply.



**A4G0405M04U04GMN**

### Grooving and Turning Inserts

**A4**

Tooling System

**A4** = Grooving and Turning

**G**

Insert Type

**G** = Square  
**R** = Full radius  
**C** = Cut-off

**0405**

Groove Width

Expressed in 1/100mm or .00"

**M**

Unit of Measurement for Grooving Width

**M** = Metric

**04**

Seat Size

**U**

Insert Tolerance

**04**

Corner Radii

**GMN**

Chipbreaker Type/Edge Prep

**GMN** = Grooving and turning medium machining stable cutting edge

**GMP** = Grooving and turning medium machining positive rake angle

**GUP** = Grooving and turning high positive geometry. Especially in stainless steels and high-temp alloys

**B** = Flat top for special forms and applications

**E** = Flat top, slight honed edge

**S** = Negative land plus hone

**ST** = Single tip

pocket seat size

cutting width (mm)

**02**

2,00–2,62

**2B**

2,39–2,62

**03**

3,0–3,05

**04**

4,0–4,05

**05**

5,0–5,05

**06**

6,0–6,05

**08**

8,0–8,05

**10**

10,0–10,05

**2S**

2,00–2,62

**3S**

3,00–3,05

**4S**

4,00–4,05

**5S**

5,00–5,05

**P** = Precision ground grooving width tolerance: ± .001" (0,025mm)

**U** = Utility moulded grooving width tolerance:  
3,05–4,05:  $\frac{+0,15\text{mm}}{-0}$   
5,05–10,05:  $\frac{+0,25\text{mm}}{-0}$

metric

**01** = 0,1

**02** = 0,2

**04** = 0,4

**08** = 0,8

**12** = 1,2

full radius = **00**

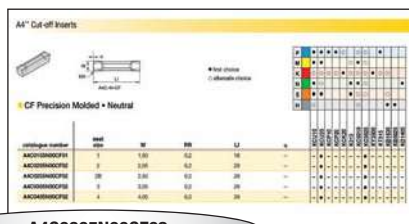

**A4C0305N00CF02**

### Grooving and Cut-Off

**A4**

Tooling System

**A4** = Grooving and Turning

**C**

Insert Type

**C** = Cut-off

**0305**

Cutting Width

Expressed in 1/100mm

**N**

Hand of Insert

**R** = Right hand  
**L** = Left hand  
**N** = Neutral

**00**

Main Cutting Edge Lead Angle

**00** = Neutral  
**06** = 6°  
**10** = 10°

**CF**

Chipbreaker Type

**CF** = Cut-off fine positive rake

**02**

Corner Radius

metric  
02 = 0,2

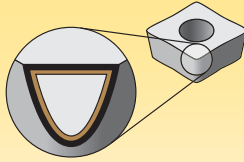

Coatings provide high-speed capability and are engineered for finishing to light roughing.

P	Steel
M	Stainless Steel
K	Cast Iron
N	Non-Ferrous
S	High-Temp Alloys
H	Hardened Materials

wear resistance ← → toughness

Grades	Coating	Grade Description	Material																		
			P	M	K	N	S	H	05	10	15	20	25	30	35	40	45				
KCUI10		<p><b>Composition:</b> An advanced multilayer PVD coating over a very deformation-resistant unalloyed carbide substrate. The new and improved coating improves edge stability with wide range speed and feed capabilities.</p> <p><b>Application:</b> The KCUI10™ grade is ideal for finishing to general machining of most workpiece materials at a wide range of speed and feed capabilities. Excellent for machining most steels, stainless steels, cast irons, non-ferrous materials, and high-temp alloys with improved edge toughness, notch resistance, and higher cutting speed/feed capability.</p>	P																		
KCUI25		<p><b>Composition:</b> An advanced PVD grade with hard AlTiN coating and fine-grain unalloyed substrate. The new and improved coating improves edge stability with wide range speed and feed capabilities.</p> <p><b>Application:</b> The KCUI25™ grade is ideal for general machining of most steels, stainless steels, high-temp alloys, titanium, irons, and non-ferrous materials in a wide range of speeds and feeds with improved edge toughness for interrupted cut and high feed rates.</p>	P																		
KCP10		<p><b>Composition:</b> A specially engineered cobalt-enriched carbide grade with thick MTCVD TiCN-Al<sub>2</sub>O<sub>3</sub> coating for maximum wear resistance.</p> <p><b>Application:</b> An excellent finishing to medium machining grade for a variety of workpiece materials, including most steels, ferritic, martensitic, and PH stainless steels, and cast irons. The cobalt-enriched substrate offers a balanced combination of deformation resistance and edge toughness, while the thick coating layers offer outstanding abrasion resistance and crater wear resistance for high-speed machining. Smooth coating provides resistance to edge build-up and microchipping and produces excellent surface finishes.</p>	P																		
KCP25		<p><b>Composition:</b> A tough cobalt-enriched carbide grade with a multilayer MTCVD TiCN-Al<sub>2</sub>O<sub>3</sub> coating with superior interlayer adhesion.</p> <p><b>Application:</b> Best general-purpose turning grade for most steels and ferritic and martensitic stainless steels. The substrate design ensures adequate deformation resistance with excellent insert edge strength. Coating layers offer good wear resistance over a wide range of machining conditions and the post-coat treatment minimises microchipping and improves coating adhesion to substrate leading to long tool life and improved workpiece finishes.</p>	P																		
KCK20		<p><b>Composition:</b> A specially toughened MTCVD TiCN-Al<sub>2</sub>O<sub>3</sub> coating over a wear-resistant substrate.</p> <p><b>Application:</b> Specifically engineered to maximise coating adhesion and edge strength making this grade ideal in wet interrupted cutting of grey and ductile irons. It can be used in a wide range of applications from finishing to roughing to maximise productivity wherever strength and reliability are needed.</p>	P																		

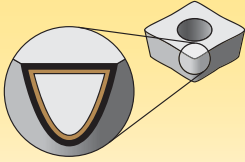

Coatings provide high-speed capability and are engineered for finishing to light roughing.

P	Steel
M	Stainless Steel
K	Cast Iron
N	Non-Ferrous
S	High-Temp Alloys
H	Hardened Materials

wear resistance ← → toughness

Grades

Coating	Grade Description		05	10	15	20	25	30	35	40	45	
K313	<p><b>Composition:</b> A hard, low binder content, unalloyed WC/Co fine-grain grade.</p> <p><b>Application:</b> Exceptional edge wear resistance combined with very high strength for machining titanium, cast irons, austenitic stainless steels, non-ferrous metals, non-metals, and most high-temp alloys. Superior thermal deformation and depth-of-cut notch resistance. The grain structure is well controlled for minimal pits and flaws, which contributes to long, reliable service.</p>											
		M										
		K										
		N										
		S										
KC5010	<p><b>Composition:</b> An advanced PVD AlTiN coating over a very deformation-resistant unalloyed carbide substrate.</p> <p><b>Application:</b> The KC5010™ grade is ideal for finishing to general machining of most workpiece materials at higher speeds. Excellent for machining most steels, stainless steels, cast irons, non-ferrous materials, and high-temp alloys under stable conditions. It also performs well machining hardened and short chipping materials.</p>	P										
		M										
		K										
		N										
		S										
		H										
KC5025	<p><b>Composition:</b> An advanced PVD-AlTiN-coated grade with a tough, ultra-fine-grain unalloyed substrate.</p> <p><b>Application:</b> For general-purpose machining of most steels, stainless steels, high-temp alloys, titanium, irons, and non-ferrous materials. Speeds may vary from low to medium and will handle interruptions and high feed rates.</p>	P										
		M										
		K										
		N										
		S										

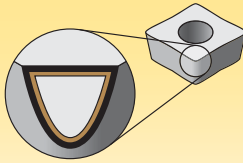

Coatings provide high-speed capability and are engineered for finishing to light roughing.

P	Steel
M	Stainless Steel
K	Cast Iron
N	Non-Ferrous
S	High-Temp Alloys
H	Hardened Materials

wear resistance ← → toughness

Grades

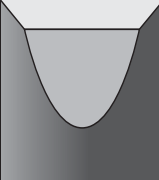
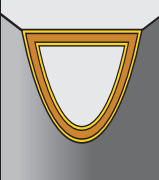
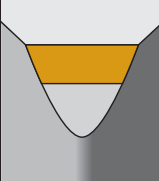
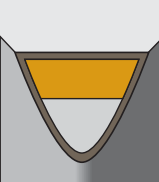
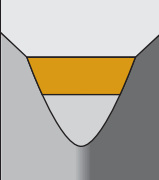
Coating	Grade Description		05	10	15	20	25	30	35	40	45
KY3500	 <b>Composition:</b> Pure silicon nitride grade. <b>Application:</b> Maximum toughness. Used at high feed rates for rough machining of grey cast iron, including machining through interruptions.										
		K									
KT315	 <b>Composition:</b> A multilayer PVD TiN/TiCN/TiN-coated cermet turning grade. <b>Application:</b> Ideal for high-speed finishing to medium machining of most carbon and alloy steels and stainless steels. Performs very well in cast and ductile iron applications, too. Provides long and consistent tool life and will produce excellent workpiece finishes.	P									
		K									
KB1630	 <b>Composition:</b> An uncoated high content PcBN grade. PcBN tips are brazed onto a carbide insert. <b>Application:</b> Designed for roughing to finishing in interrupted cuts on hardened steels (>45 HRC). It can also be applied on grey cast iron, chilled irons, high chrome alloyed steels, high temp alloys and sintered powder metals. The tipped PcBN inserts are available in a wide range of insert styles, including Top Notch™ and Screw-On geometries.										
		K									
KB5625	 <b>Composition:</b> A medium content PcBN with a PVD-TiN/AlTiN coating for added wear resistance. <b>Application:</b> Designed for roughing to finishing of hardened steels (>45 HRC). Use on bearing steels, hot and cold work steels, die steels, case hardened steels, carburised and nitrided irons, and some hard coatings.										
		H									
KD1405	 <b>Composition:</b> A pure CVD-deposited diamond-sheet tool brazed directly to a carbide substrate. <b>Application:</b> KD1405™ is the best Kennametal abrasion-resistant tool material for non-ferrous and non-metallic materials. Best applied when abrasion resistance is the desired benefit.										
		N									

### Select the geometry

P	Steel
M	Stainless Steel
K	Cast Iron
N	Non-Ferrous
S	High-Temp Alloys
H	Hardened Materials

- first choice
- alternate choice

Chip Control	Description	Insert Geometry	Seat Size	Corner Radius	Starting Conditions	Plunge Feed Rates mm/rev							
				mm	mm	0,05	0,10	0,15	0,20	0,25	0,30	0,35	
-GUP	Groove and turn inserts in new Beyond™ grades.		2	0,2	0,08								
			3	0,2	0,09								
			3	0,4	0,11								
			4	0,4	0,12								
			4	0,8	0,15								

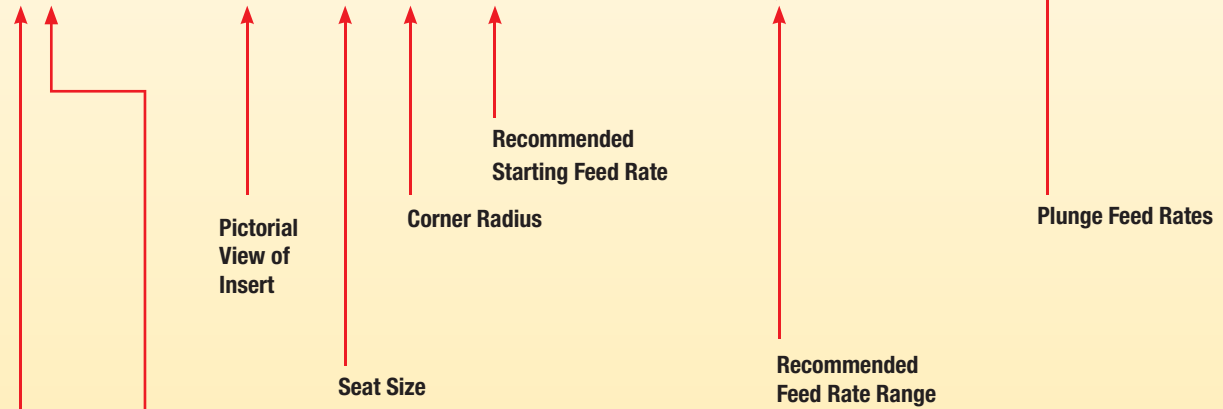

### Primary Workpiece Material Group

P	Steel
M	Stainless Steel
K	Cast Iron
N	Non-Ferrous
S	High-Temp Alloys
H	Hardened Materials

- first choice
- alternate choice

### Chip Control Geometry Designation

### Maximum Feed Rate Values

Data above is for P and K material groups. <b>Maximum</b> feed rates should be adjusted by multiplying max feed rate values by following factors for shown material groups.	Material Group	Feed Factor
	M	.8
	N	1.2
	S	.8
	H	.5

### Plunge Feed Rates

- first choice
- alternate choice

P	Steel
M	Stainless Steel
K	Cast Iron
N	Non-Ferrous
S	High-Temp Alloys
H	Hardened Materials

Chip Control	Description	Insert Geometry	Seat Size	Corner Radius	Starting Conditions	Plunge Feed Rates mm/rev								
						0,05	0,10	0,15	0,20	0,25	0,30	0,35		
-GUP	<ul style="list-style-type: none"> <li>Groove and turn inserts in new Beyond™ grades.</li> <li>Available in moulded and precision-ground styles.</li> <li>Positive rake angle with enhanced chip control.</li> <li>Available in metric widths only.</li> </ul>		2	0,2	0,08	●	○							
				0,2	0,09	○	○							
			3	0,4	0,11		○	○						
				0,4	0,12			○	○					
			4	0,8	0,15				○	○				
				0,4	0,15					○	○			
			5	0,8	0,16						○	○		
				0,4	0,16							○	○	
			6	0,8	0,18								○	○
				1,2	0,20									○
			8	0,4	0,17									○
				0,8	0,20									
10	1,2	0,22												
	0,4	0,18												
-GMP	<ul style="list-style-type: none"> <li>Groove and turn inserts.</li> <li>Available in moulded and precision-ground styles.</li> <li>Positive rake angle.</li> <li>Available in metric widths only.</li> </ul>		2	0,2	0,08	●	○							
				0,2	0,09	○	○							
			3	0,4	0,11		○	○						
				0,4	0,12			○	○					
			4	0,8	0,15				○	○				
				0,4	0,15					○	○			
			5	0,8	0,16						○	○		
				0,4	0,16							○	○	
			6	0,8	0,18								○	○
				1,2	0,20									○
			8	0,4	0,17									○
				0,8	0,20									
10	1,2	0,22												
	0,4	0,18												
-GMN	<ul style="list-style-type: none"> <li>Groove and turn moulded and precision ground inserts.</li> <li>Stable cutting edge.</li> <li>Available in metric and inch widths.</li> </ul>		2	0,2	0,08	●	○							
				0,2	0,09	○	○							
			3	0,4	0,11		○	○						
				0,4	0,12			○	○					
			4	0,8	0,15				○	○				
				0,4	0,15					○	○			
			5	0,8	0,16						○	○		
				0,4	0,16							○	○	
			6	0,8	0,18								○	○
				1,2	0,20									○
			8	0,4	0,17									○
				0,8	0,20									
10	1,2	0,22												
	0,4	0,18												

### Maximum Feed Rate Values

Data above is for P and K material groups. **Maximum** feed rates should be adjusted by multiplying max feed rate values by following factors for shown material groups.

Material Group	Feed Factor
M	.8
N	.8
S	.5
H	1.2

### I.D. and Face Grooving

For I.D. and face grooving applications, reduce feed rate by 20%.

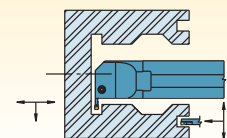



■ Turn and profile feed rates • GUP/GMP Geometries

**Seat Size 2**

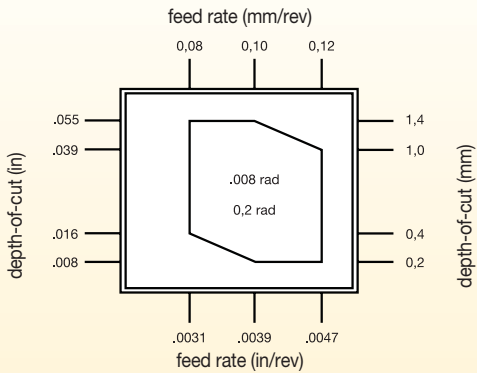

**Seat Size 3**

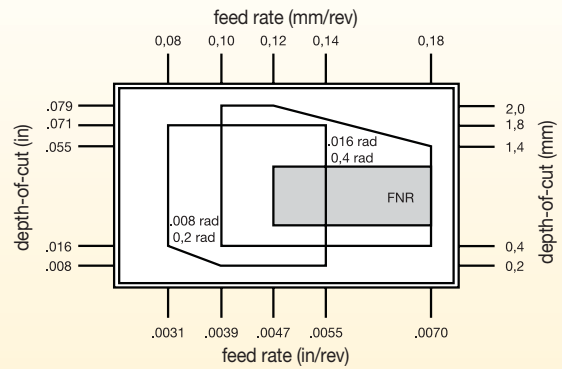

**Seat Size 4**

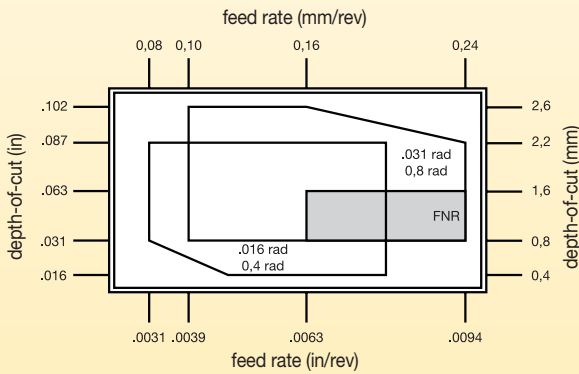

**Seat Size 5**

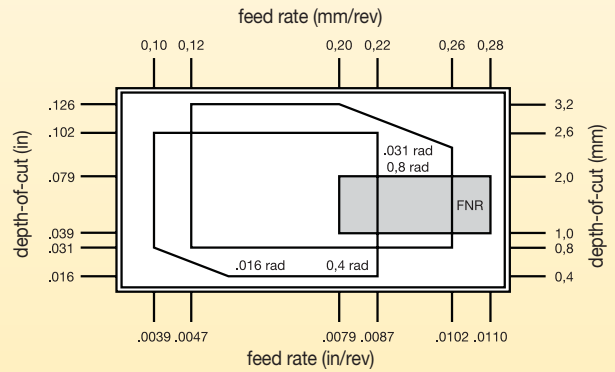

**Seat Size 6**

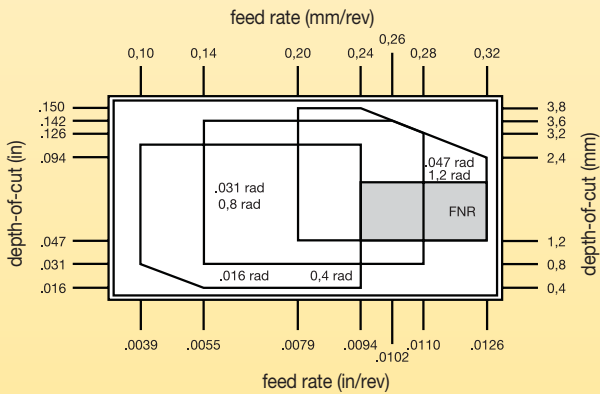

**Seat Size 8**

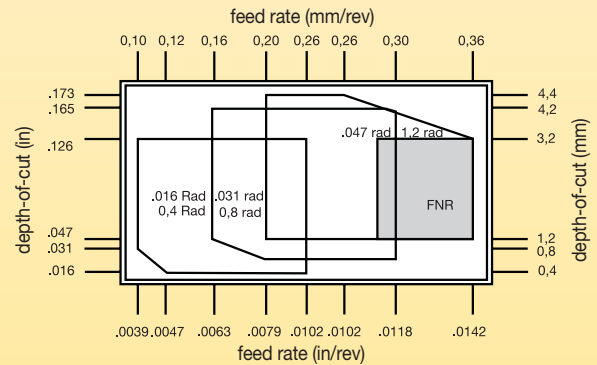

**Seat Size 10**

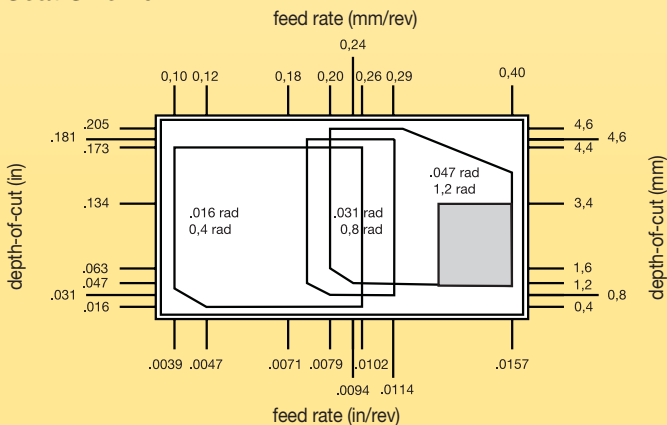

Turn and profile feed rates • GMN Geometries

Seat Size 2

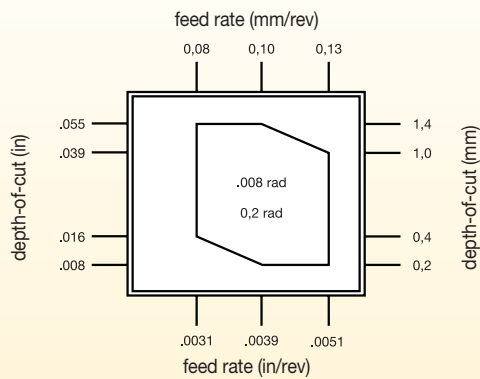

Seat Size 3

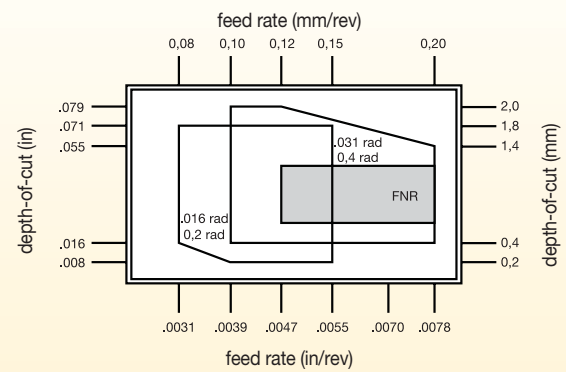

Seat Size 4

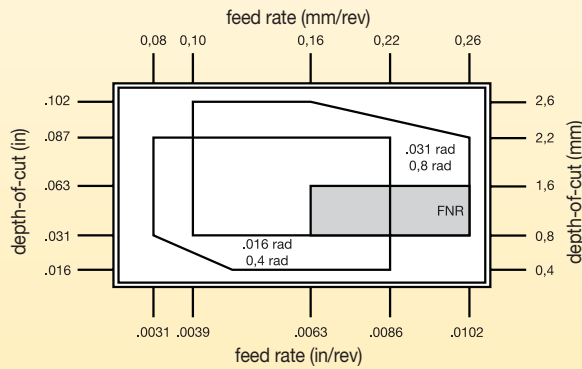

Seat Size 5

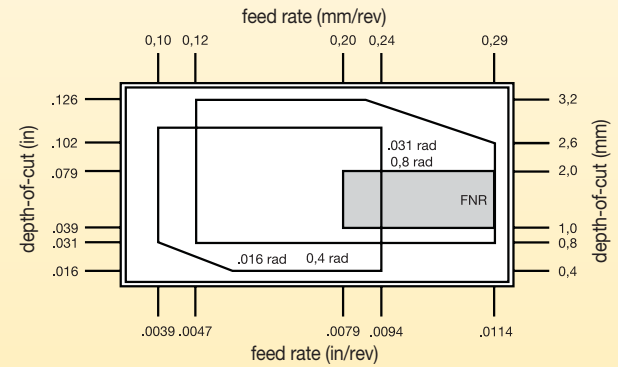

Seat Size 6

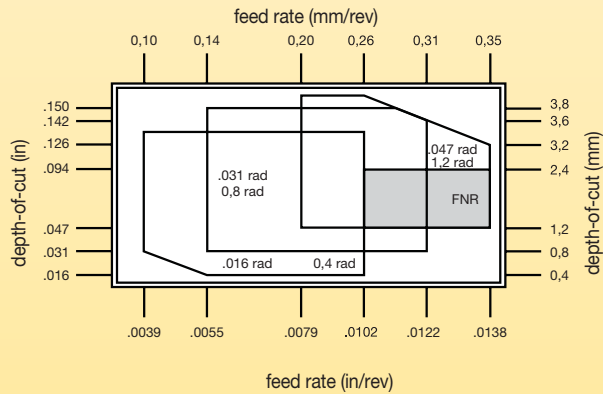

Seat Size 8

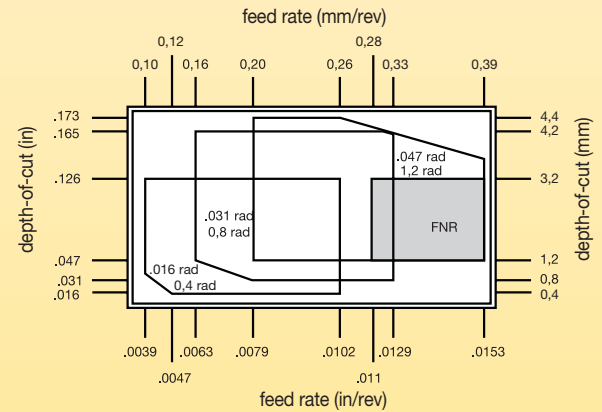

Seat Size 10

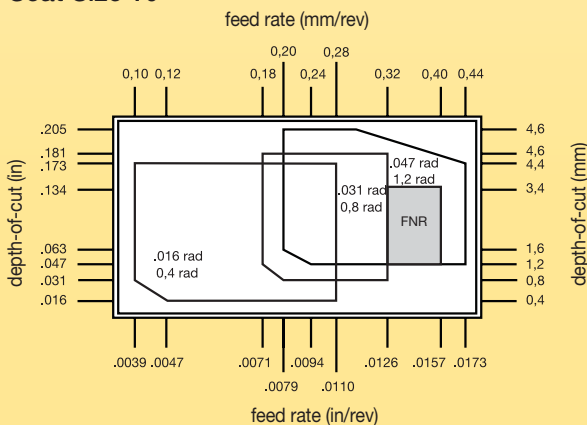

### ■ Cut-Off Feed Rates

P	Steel
M	Stainless Steel
K	Cast Iron
N	Non-Ferrous
S	High-Temp Alloys
H	Hardened Materials

- first choice
- alternate choice

Chip Control	Description	Insert Geometry	Seat Size	Starting Conditions	Cut-Off Feed Rates mm/rev			
				mm	0,05	0,10	0,15	0,20
-A4C-CF 	<ul style="list-style-type: none"> <li>• High positive rake angle.</li> <li>• Sharp cutting edge.</li> <li>• Available in neutral lead angle in 6° and 10° right- and left-hand styles.</li> </ul>		1	0,06				
			2/2B	0,07				
			3	0,09				
			4	0,11				

### Maximum Feed Rate Values

Data above is for P and K material groups. <b>Maximum</b> feed rates should be adjusted by multiplying max feed rate values by following factors for shown material groups.	Material Group	Feed Factor
	M	.8
	N	.8
	S	.5
	H	1.2

# Mobile Apps

The Kennametal mobile app provides easy access to product information and calculators on both iPhone® and Android™ devices. We've highlighted a few of the key features...

There's an app for that.

#### SPEEDS & FEEDS

View speeds and feeds information for metalworking products.

#### PRODUCT AVAILABILITY

Check global availability of products. View available quantities by providing your Kennect login credentials.

#### CALCULATORS

Utilise our machining calculators for milling and drilling applications.

➔ By just scanning the bar code on the insert packet, you can find the most productive cutting conditions for tool life, process time, and chip control.

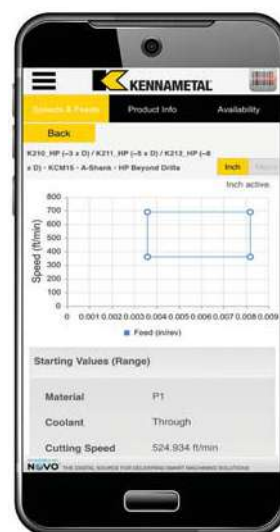

NOTE: The app is currently only available in the English-language version. We have plans to translate the app in different languages with future releases.



Recommended Starting Speeds [m/min]

Material Group		K313	KCU10/KC5010	KCU25/KC5025	KCP10	KCP25	KCK20B	KY3500
P	0-1	- - -	140 <b>280</b> 335	110 <b>225</b> 270	185 <b>400</b> 450	145 <b>290</b> 365	200 <b>440</b> 490	- - -
	2	- - -	140 <b>200</b> 245	110 <b>160</b> 195	185 <b>270</b> 350	145 <b>200</b> 305	200 <b>300</b> 380	- - -
	3	- - -	140 <b>155</b> 245	110 <b>125</b> 195	170 <b>190</b> 260	140 <b>155</b> 245	600 <b>200</b> 280	- - -
	4	- - -	75 <b>110</b> 170	60 <b>90</b> 135	90 <b>145</b> 200	75 <b>110</b> 180	100 <b>160</b> 220	- - -
	5	- - -	120 <b>200</b> 260	100 <b>160</b> 210	150 <b>220</b> 305	120 <b>200</b> 270	165 <b>240</b> 330	- - -
	6	- - -	110 <b>150</b> 230	85 <b>120</b> 185	120 <b>180</b> 275	110 <b>150</b> 230	130 <b>190</b> 300	- - -
M	1	60 <b>90</b> 120	140 <b>210</b> 260	90 <b>170</b> 245	- - -	- - -	- - -	- - -
	2	45 <b>75</b> 110	120 <b>200</b> 245	90 <b>150</b> 245	- - -	- - -	- - -	- - -
	3	35 <b>65</b> 100	120 <b>180</b> 245	90 <b>140</b> 210	- - -	- - -	- - -	- - -
K	1	30 <b>75</b> 120	120 <b>180</b> 245	100 <b>145</b> 195	170 <b>245</b> 440	140 <b>200</b> 360	210 <b>305</b> 550	180 <b>760</b> 1040
	2	25 <b>70</b> 110	90 <b>150</b> 210	70 <b>120</b> 170	120 <b>195</b> 340	100 <b>160</b> 280	150 <b>245</b> 430	275 <b>365</b> 500
	3	20 <b>60</b> 90	60 <b>110</b> 150	50 <b>85</b> 120	120 <b>170</b> 270	100 <b>140</b> 220	150 <b>210</b> 335	- - -
N	1-2	150 <b>370</b> 610	150 <b>550</b> 975	120 <b>440</b> 780	- - -	- - -	- - -	- - -
	3	- - -	- - -	- - -	- - -	- - -	- - -	- - -
	4	120 <b>275</b> 430	120 <b>365</b> 610	100 <b>290</b> 490	- - -	- - -	- - -	- - -
	5	45 <b>90</b> 150	90 <b>170</b> 245	70 <b>135</b> 195	- - -	- - -	- - -	- - -
	6	40 <b>75</b> 150	120 <b>210</b> 305	100 <b>170</b> 245	- - -	- - -	- - -	- - -
S	1	8 <b>30</b> 75	15 <b>55</b> 135	8 <b>40</b> 60	- - -	- - -	- - -	- - -
	2	8 <b>35</b> 75	15 <b>60</b> 135	8 <b>30</b> 75	- - -	- - -	- - -	- - -
	3	8 <b>40</b> 75	15 <b>70</b> 135	15 <b>40</b> 75	- - -	- - -	- - -	- - -
	4	8 <b>45</b> 75	15 <b>70</b> 170	8 <b>50</b> 110	- - -	- - -	- - -	- - -
H	1	- - -	30 <b>45</b> 60	- - -	- - -	- - -	- - -	- - -
	2	- - -	15 <b>30</b> 45	- - -	- - -	- - -	- - -	- - -
	3	- - -	- - -	- - -	- - -	- - -	- - -	- - -
	4	- - -	- - -	- - -	- - -	- - -	- - -	- - -



Material Group		KT315	KB5625	KB1630	KD1405
P	0-1	180 <b>440</b> 475	- - -	- - -	- - -
	2	195 <b>270</b> 400	- - -	- - -	- - -
	3	180 <b>210</b> 275	- - -	- - -	- - -
	4	75 <b>160</b> 210	- - -	- - -	- - -
	5	150 <b>250</b> 310	- - -	- - -	- - -
	6	140 <b>200</b> 300	- - -	- - -	- - -
M	1	- - -	- - -	- - -	- - -
	2	- - -	- - -	- - -	- - -
	3	- - -	- - -	- - -	- - -
K	1	60 <b>275</b> 550	- - -	180 <b>760</b> 1040	- - -
	2	135 <b>275</b> 360	- - -	- - -	- - -
	3	180 <b>230</b> 360	- - -	- - -	- - -
N	1-2	- - -	- - -	- - -	365 <b>610</b> 1040
	3	- - -	- - -	- - -	275 <b>480</b> 800
	4	- - -	- - -	- - -	300 <b>550</b> 920
	5	- - -	- - -	- - -	275 <b>610</b> 1070
	6	- - -	- - -	- - -	150 <b>460</b> 760
	S	1	- - -	- - -	120 <b>200</b> 275
2		- - -	- - -	120 <b>215</b> 275	- - -
3		- - -	- - -	120 <b>250</b> 275	- - -
4		- - -	- - -	- - -	- - -
H	1	- - -	45 <b>150</b> 230	45 <b>120</b> 170	- - -
	2	- - -	45 <b>140</b> 230	45 <b>110</b> 170	- - -
	3	- - -	45 <b>130</b> 230	45 <b>100</b> 170	- - -
	4	- - -	45 <b>120</b> 230	45 <b>90</b> 170	- - -

NOTE: FIRST choice starting speeds are in **bold** type.  
As the average chip thickness increases, the speed should be decreased.

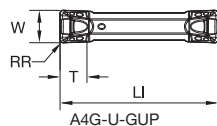
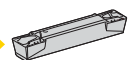

- first choice
- alternate choice

P	●	●	●	●	○	○	○	●				
M	●	●				○	●					
K	○	○	○	●	○	○	○	●	○	○		
N	●	○				●	●	○				●
S	●	●				●	○	○		○		
H	○						○			●	●	

## ■ GUP Precision Moulded

catalogue number	seat size	W	RR	LI	T	KCU10	KCU25	KCP10	KCP25	KCK20	K313	KC5010	KC5025	KY3500	KT315	KB1630	KB5625	KD1405	
A4G0205M02U02GUP	2	2,05	0,2	20	2,0	●	●	●	●	-	-	-	-	-	-	-	-	-	-
A4G0305M03U02GUP	3	3,05	0,2	20	3,0	●	●	●	●	-	-	-	-	-	-	-	-	-	-
A4G0305M03U04GUP	3	3,05	0,4	20	3,0	●	●	●	●	-	-	-	-	-	-	-	-	-	-
A4G0405M04U04GUP	4	4,05	0,4	20	3,4	●	●	●	●	-	-	-	-	-	-	-	-	-	-
A4G0405M04U08GUP	4	4,05	0,8	20	3,4	●	●	●	●	-	-	-	-	-	-	-	-	-	-
A4R0405M04U00GUP	4	4,05	-	20	-	-	●	-	-	-	-	-	-	-	-	-	-	-	-
A4G0505M05U04GUP	5	5,05	0,4	25	4,2	●	●	●	●	-	-	-	-	-	-	-	-	-	-
A4G0505M05U08GUP	5	5,05	0,8	25	4,2	●	●	●	●	-	-	-	-	-	-	-	-	-	-
A4G0605M06U04GUP	6	6,05	0,4	30	4,5	●	●	●	●	-	-	-	-	-	-	-	-	-	-
A4G0605M06U08GUP	6	6,05	0,8	30	4,5	●	●	●	●	-	-	-	-	-	-	-	-	-	-
A4G0605M06U12GUP	6	6,05	1,2	30	4,5	●	●	●	●	-	-	-	-	-	-	-	-	-	-
A4R0605M06U00GUP	6	6,05	-	30	4,9	-	●	-	-	-	-	-	-	-	-	-	-	-	-
A4G0805M08U08GUP	8	8,05	0,8	30	6,0	●	●	●	●	-	-	-	-	-	-	-	-	-	-
A4G0805M08U12GUP	8	8,05	1,2	30	6,0	●	●	●	●	-	-	-	-	-	-	-	-	-	-
A4R0805M08U00GUP	8	8,05	-	30	6,5	-	●	-	-	-	-	-	-	-	-	-	-	-	-
A4G1005M10U08GUP	10	10,05	0,8	30	6,0	●	●	●	-	-	-	-	-	-	-	-	-	-	-
A4G1005M10U12GUP	10	10,05	1,2	30	6,1	-	●	-	-	-	-	-	-	-	-	-	-	-	-

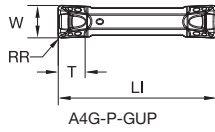
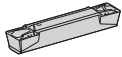

● first choice  
○ alternate choice

	P	M	K	N	S	H	KCU10	KCU25	KCP10	KCP25	KCK20	K313	KC5010	KC5025	KY3500	KT315	KB1630	KB5625	KD1405	
P	●	●	●	○	○	○	○	○	○	○	○	○	○	○	○	○	○	○	○	○
M	●	●	○	○	○	○	○	○	○	○	○	○	○	○	○	○	○	○	○	○
K	○	○	○	○	○	○	○	○	○	○	○	○	○	○	○	○	○	○	○	○
N	●	○	○	○	○	○	○	○	○	○	○	○	○	○	○	○	○	○	○	○
S	●	●	○	○	○	○	○	○	○	○	○	○	○	○	○	○	○	○	○	○
H	○	○	○	○	○	○	○	○	○	○	○	○	○	○	○	○	○	○	○	○

### GUP Precision Ground

catalogue number	seat size	W	RR	LI	T	KCU10	KCU25	KCP10	KCP25	KCK20	K313	KC5010	KC5025	KY3500	KT315	KB1630	KB5625	KD1405	
A4G0200M02P02GUP	2	2,00	0,2	20	1,9	●	●	-	-	-	-	-	-	-	-	-	-	-	-
A4G094I2BP05GUP	2B	2,38	0,2	20	1,9	-	●	-	-	-	-	-	-	-	-	-	-	-	-
A4G0300M03P02GUP	3	3,00	0,2	20	2,9	●	●	-	-	-	-	-	-	-	-	-	-	-	-
A4G0300M03P04GUP	3	3,00	0,4	20	2,9	●	●	-	-	-	-	-	-	-	-	-	-	-	-
A4G125I03P05GUP	3	3,18	0,2	20	2,9	-	●	-	-	-	-	-	-	-	-	-	-	-	-
A4G125I03P1GUP	3	3,18	0,4	20	2,9	-	●	-	-	-	-	-	-	-	-	-	-	-	-
A4G0400M04P02GUP	4	4,00	0,2	20	3,3	●	●	-	-	-	-	-	-	-	-	-	-	-	-
A4G0400M04P04GUP	4	4,00	0,4	20	3,3	●	●	-	-	-	-	-	-	-	-	-	-	-	-
A4G0400M04P08GUP	4	4,00	0,8	20	3,3	●	●	-	-	-	-	-	-	-	-	-	-	-	-
A4G187I04P1GUP	4	4,76	0,4	20	3,3	-	●	-	-	-	-	-	-	-	-	-	-	-	-
A4G0500M05P04GUP	5	5,00	0,4	25	4,1	●	●	-	-	-	-	-	-	-	-	-	-	-	-
A4G0500M05P08GUP	5	5,00	0,8	25	4,1	●	●	-	-	-	-	-	-	-	-	-	-	-	-
A4G0600M06P04GUP	6	6,00	0,4	30	4,5	●	●	-	-	-	-	-	-	-	-	-	-	-	-
A4G0600M06P08GUP	6	6,00	0,8	30	4,5	●	●	-	-	-	-	-	-	-	-	-	-	-	-
A4G250I06P1GUP	6	6,35	0,4	30	4,4	-	●	-	-	-	-	-	-	-	-	-	-	-	-
A4G250I06P2GUP	6	6,35	0,8	30	4,4	-	●	-	-	-	-	-	-	-	-	-	-	-	-
A4G312I08P1GUP	8	7,94	0,4	30	5,9	-	●	-	-	-	-	-	-	-	-	-	-	-	-
A4G0800M08P08GUP	8	8,00	0,8	30	6,0	●	●	-	-	-	-	-	-	-	-	-	-	-	-
A4G0800M08P12GUP	8	8,00	1,2	30	6,0	●	●	-	-	-	-	-	-	-	-	-	-	-	-
A4G375I10P1GUP	10	9,53	0,4	30	5,9	-	●	-	-	-	-	-	-	-	-	-	-	-	-
A4G1000M10P08GUP	10	10,00	0,8	30	6,0	●	●	-	-	-	-	-	-	-	-	-	-	-	-
A4G1000M10P12GUP	10	10,00	1,2	30	6,0	●	●	-	-	-	-	-	-	-	-	-	-	-	-

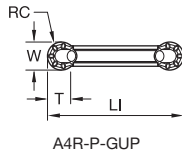
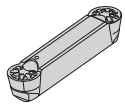

■ GUP Full Radius Precision Moulded

catalogue number	seat size	W	RC	LI	T
A4R0305M03U00GUP	3	3,05	1,5	20	—
A4R0505M05U00GUP	5	5,05	2,5	25	—
A4R1005M10U00GUP	10	10,05	5,0	30	—

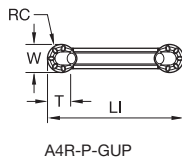
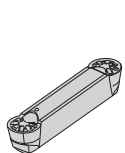

■ GUP Full Radius Precision Ground

catalogue number	seat size	W	RC	LI	T
A4R0300M03P00GUP	3	3,00	1,5	20	—
A4R125I03P00GUP	3	3,18	1,6	20	—
A4R0400M04P00GUP	4	4,00	2,0	20	—
A4R187I04P00GUP	4	4,76	2,4	20	—
A4R0500M05P00GUP	5	5,00	2,5	25	—
A4R0600M06P00GUP	6	6,00	3,0	30	—
A4R250I06P00GUP	6	6,35	3,2	30	—
A4R312I08P00GUP	8	7,94	4,0	30	—
A4R0800M08P00GUP	8	8,00	4,0	30	—
A4R1000M10P00GUP	10	10,00	5,0	30	—

● first choice  
○ alternate choice

	KCU10	KGU25	KCP10	KCP25	KCK20	K313	KC5010	KC5025	KY3500	KT315	KB1630	KB5625	KD1405
P	●	●	●	●	○	○	○	○	○	○	○	○	○
M	●	●	○	○	○	○	○	○	○	○	○	○	○
K	○	○	○	○	○	○	○	○	○	○	○	○	○
N	●	○	○	○	○	○	○	○	○	○	○	○	○
S	●	●	○	○	○	○	○	○	○	○	○	○	○
H	○	○	○	○	○	○	○	○	○	○	○	○	○

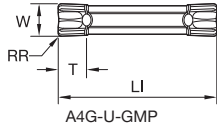
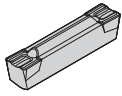

■ GMP Precision Moulded

catalogue number	seat size	W	RR	LI	T																			
						KCU10	KCU25	KCP10	KCP25	KCK20	K313	KC5010	KC5025	KY3500	KT315	KB1630	KB5625	KD1405						
A4G0205M02U02GMP	2	2,05	0,2	20	2,0	-	●	●	●	●	○	○	○	○	○	○	○	○	○	○	○	○	○	○
A4G0255M2BU02GMP	2B	2,62	0,2	20	2,0	-	●	-	-	-	-	-	-	-	-	-	-	-	-	-	-	-	-	-
A4G0305M03U02GMP	3	3,05	0,2	20	3,5	●	●	-	-	-	-	-	-	-	-	-	-	-	-	-	-	-	-	-
A4G0305M03U04GMP	3	3,05	0,4	20	3,5	●	●	-	-	-	-	-	-	-	-	-	-	-	-	-	-	-	-	-
A4G0405M04U04GMP	4	4,05	0,4	20	3,4	●	●	●	●	-	-	-	-	-	-	-	-	-	-	-	-	-	-	-
A4G0405M04U08GMP	4	4,05	0,8	20	3,4	-	●	-	-	-	-	-	-	-	-	-	-	-	-	-	-	-	-	-
A4G0505M05U04GMP	5	5,05	0,4	25	4,2	●	●	●	-	-	-	-	-	-	-	-	-	-	-	-	-	-	-	-
A4G0505M05U08GMP	5	5,05	0,8	25	4,2	-	●	●	-	-	-	-	-	-	-	-	-	-	-	-	-	-	-	-
A4G0605M06U04GMP	6	6,05	0,4	30	4,9	-	-	-	●	-	-	-	-	-	-	-	-	-	-	-	-	-	-	-
A4G0605M06U08GMP	6	6,05	0,8	30	4,9	-	-	-	-	-	-	-	-	-	-	-	-	-	-	-	-	-	-	-
A4G0805M08U08GMP	8	8,05	0,8	30	6,1	-	●	-	-	-	-	-	-	-	-	-	-	-	-	-	-	-	-	-
A4G1005M10U08GMP	10	10,05	0,8	30	8,1	●	●	-	-	-	-	-	-	-	-	-	-	-	-	-	-	-	-	-

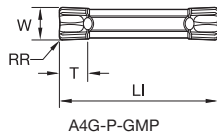
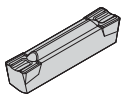

■ GMP Precision Ground

catalogue number	seat size	W	RR	LI	T																			
						KCU10	KCU25	KCP10	KCP25	KCK20	K313	KC5010	KC5025	KY3500	KT315	KB1630	KB5625	KD1405						
A4G0200M02P02GMP	2	2,00	0,2	20	2,0	●	●	-	-	-	-	-	-	-	-	-	-	-	-	-	-	-	-	-
A4G0250M2BP02GMP	2B	2,50	0,2	20	2,0	●	-	-	-	-	-	-	-	-	-	-	-	-	-	-	-	-	-	-
A4G0300M03P02GMP	3	3,00	0,2	20	3,5	●	●	-	-	-	-	-	-	-	-	-	-	-	-	-	-	-	-	-
A4G0300M03P04GMP	3	3,00	0,4	20	3,5	●	●	-	-	-	-	-	-	-	-	-	-	-	-	-	-	-	-	-
A4G0400M04P02GMP	4	4,00	0,2	20	—	●	●	-	-	-	-	-	-	-	-	-	-	-	-	-	-	-	-	-
A4G0400M04P04GMP	4	4,00	0,4	20	3,5	●	●	-	-	-	-	-	-	-	-	-	-	-	-	-	-	-	-	-
A4G0400M04P08GMP	4	4,00	0,8	20	3,5	●	●	-	-	-	-	-	-	-	-	-	-	-	-	-	-	-	-	-
A4G0500M05P04GMP	5	5,00	0,4	25	—	●	●	-	-	-	-	-	-	-	-	-	-	-	-	-	-	-	-	-
A4G0500M05P08GMP	5	5,00	0,8	25	—	●	-	-	-	-	-	-	-	-	-	-	-	-	-	-	-	-	-	-
A4G0600M06P04GMP	6	6,00	0,4	30	4,9	●	●	-	-	-	-	-	-	-	-	-	-	-	-	-	-	-	-	-
A4G0600M06P08GMP	6	6,00	0,8	30	4,9	●	-	-	-	-	-	-	-	-	-	-	-	-	-	-	-	-	-	-
A4G0800M08P08GMP	8	8,00	0,8	30	6,4	-	●	-	-	-	-	-	-	-	-	-	-	-	-	-	-	-	-	-
A4G0800M08P12GMP	8	8,00	1,2	30	6,4	●	-	-	-	-	-	-	-	-	-	-	-	-	-	-	-	-	-	-



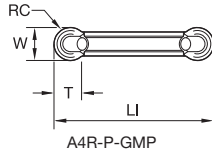
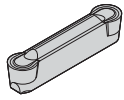

● first choice  
○ alternate choice

P	●	●	●	●	○	○	○	○	○	○	○	○	○	○	○	○	○
M	●	●	○	○	○	○	○	○	○	○	○	○	○	○	○	○	○
K	○	○	○	○	○	○	○	○	○	○	○	○	○	○	○	○	○
N	●	○	○	○	○	○	○	○	○	○	○	○	○	○	○	○	○
S	●	●	○	○	○	○	○	○	○	○	○	○	○	○	○	○	○
H	○	○	○	○	○	○	○	○	○	○	○	○	○	○	○	○	○

**■ GMP Full Radius Precision Ground**

catalogue number	seat size	W	RC	LI	T	KCU10	KCU25	KCP10	KCP25	KCK20	K313	KC5010	KC5025	KY3500	KT315	KB1630	KB5625	KD1405	
A4R0200M02P00GMP	2	2,00	1,0	20	1,7	●	●	-	-	-	-	●	●	-	-	-	-	-	-
A4R0300M03P00GMP	3	3,00	1,5	20	2,5	●	●	-	-	-	●	●	●	-	-	-	-	-	-
A4R0400M04P00GMP	4	4,00	2,0	20	-	●	●	-	-	-	●	●	●	-	-	-	-	-	-
A4R0500M05P00GMP	5	5,00	2,5	25	4,1	●	●	-	-	-	●	●	●	-	-	-	-	-	-
A4R0600M06P00GMP	6	6,00	3,0	30	4,8	●	●	-	-	-	-	●	●	-	-	-	-	-	-
A4R0800M08P00GMP	8	8,00	4,0	30	6,4	●	●	-	-	-	-	●	●	-	-	-	-	-	-

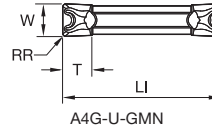
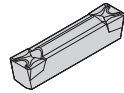

**■ GMN Precision Moulded**

catalogue number	seat size	W	RR	LI	T	KCU10	KCU25	KCP10	KCP25	KCK20	K313	KC5010	KC5025	KY3500	KT315	KB1630	KB5625	KD1405	
A4G0205M02U02GMN	2	2,05	0,2	20	2,0	●	●	-	-	-	-	●	●	-	-	-	-	-	-
A4G0255M2BU02GMN	2B	2,62	0,2	20	2,0	-	-	-	-	-	-	-	●	●	-	-	-	-	-
A4G0305M03U02GMN	3	3,05	0,2	20	3,5	●	●	●	●	-	-	●	●	-	-	-	-	-	-
A4G0305M03U04GMN	3	3,05	0,4	20	3,5	●	●	●	●	-	-	●	●	-	-	-	-	-	-
A4G0405M04U04GMN	4	4,05	0,4	20	3,4	●	●	-	-	-	-	●	●	-	-	-	-	-	-
A4G0405M04U08GMN	4	4,05	0,8	20	3,4	●	●	●	●	-	-	●	●	-	-	-	-	-	-
A4G0505M05U04GMN	5	5,05	0,4	25	4,2	●	●	●	●	-	-	●	●	-	-	-	-	-	-
A4G0505M05U08GMN	5	5,05	0,8	25	4,2	●	●	●	●	-	-	●	●	-	-	-	-	-	-
A4G0605M06U04GMN	6	6,05	0,4	30	4,9	●	●	●	●	-	-	●	●	-	-	-	-	-	-
A4G0605M06U08GMN	6	6,05	0,8	30	4,9	●	●	●	●	-	-	●	●	-	-	-	-	-	-
A4G0605M06U12GMN	6	6,05	1,2	30	4,9	-	-	-	-	-	-	●	●	-	-	-	-	-	-
A4G0805M08U08GMN	8	8,05	0,8	30	6,4	●	●	●	●	-	-	●	●	-	-	-	-	-	-
A4G0805M08U12GMN	8	8,05	1,2	30	6,4	-	-	●	●	-	-	●	●	-	-	-	-	-	-
A4G1005M10U08GMN	10	10,05	0,8	30	8,1	-	-	●	●	-	-	●	●	-	-	-	-	-	-
A4G1005M10U12GMN	10	10,05	1,2	30	8,1	-	-	●	●	-	-	●	●	-	-	-	-	-	-



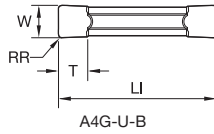
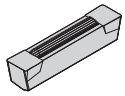

● first choice  
○ alternate choice

P	●	●	●	●	○	○	○	●											
M	●	●				○	●	○											
K	○	○	○	○	●	○	○	○	●	○	○								
N	●	○				●	●	○											●
S	●	●				●	○	○						○					
H	○							○						●	●				

### Flat Top Precision Moulded

catalogue number	seat size	W	RR	LI	T	KCU10	KCU25	KCP10	KCP25	KCK20	K313	KC5010	KC5025	KY3500	KT315	KB1630	KB5625	KD1405	
A4G0305M03U02B	3	3,05	0,2	20	3,5	-	●	-	-	●	-	-	●	-	-	-	-	-	-
A4G0405M04U04B	4	4,05	0,4	20	3,4	-	-	-	-	●	-	-	●	-	-	-	-	-	-
A4G0505M05U04B	5	5,05	0,4	25	4,2	-	●	-	-	●	-	-	-	-	-	-	-	-	-
A4G0605M06U04B	6	6,05	0,4	30	4,9	-	●	-	-	●	-	-	-	-	-	-	-	-	-
A4G0805M08U08B	8	8,05	0,8	30	6,4	-	-	-	-	●	-	-	-	-	-	-	-	-	-
A4G1005M10U08B	10	10,05	0,8	30	8,1	-	-	-	-	●	-	-	-	-	-	-	-	-	-

## A4™ Groove and Turn Inserts • Small Diameter Face Grooving

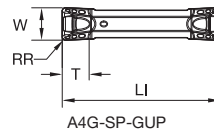
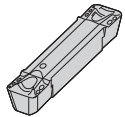

● first choice  
○ alternate choice

P	●	●	●	●	○	○	○	●											
M	●	●				○	●	○											
K	○	○	○	○	●	○	○	○	●	○	○								
N	●	○				●	●	○											●
S	●	●				●	○	○								○			
H	○							○								●	●		

### GUP Precision Moulded • Small Diameter Face Grooving

catalogue number	seat size	W	RR	LI	T	KCU10	KCU25	KCP10	KCP25	KCK20	K313	KC5010	KC5025	KY3500	KT315	KB1630	KB5625	KD1405	
A4G0200M2SP02GUP	2S	2,00	0,2	20	1,9	●	●	-	-	-	-	-	-	-	-	-	-	-	-
A4G0300M3SP02GUP	3S	3,00	0,2	20	2,9	●	●	-	-	-	-	-	-	-	-	-	-	-	-
A4G0300M3SP04GUP	3S	3,00	0,4	20	2,9	●	●	-	-	-	-	-	-	-	-	-	-	-	-
A4G0400M4SP04GUP	4S	4,00	0,4	20	3,4	●	-	-	-	-	-	-	-	-	-	-	-	-	-
A4G0400M4SP08GUP	4S	4,00	0,8	20	3,4	●	-	-	-	-	-	-	-	-	-	-	-	-	-
A4G0500M5SP04GUP	5S	5,00	0,4	25	4,1	-	●	-	-	-	-	-	-	-	-	-	-	-	-
A4G0500M5SP08GUP	5S	5,00	0,8	25	4,1	●	-	-	-	-	-	-	-	-	-	-	-	-	-

NOTE: A4-S inserts are reduced-height A4 inserts. For example, a 2S seat size holder will not accept a seat size 2 insert.

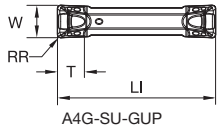
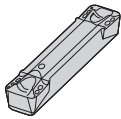

● first choice  
○ alternate choice

P	●	●	●	○	○	○	○	○	○	○	○	○	○	○	○	○	○	○	○	○
M	●	●	○	○	○	○	○	○	○	○	○	○	○	○	○	○	○	○	○	○
K	○	○	○	○	○	○	○	○	○	○	○	○	○	○	○	○	○	○	○	○
N	●	○	○	○	○	○	○	○	○	○	○	○	○	○	○	○	○	○	○	○
S	●	●	○	○	○	○	○	○	○	○	○	○	○	○	○	○	○	○	○	○
H	○	○	○	○	○	○	○	○	○	○	○	○	○	○	○	○	○	○	○	○

**■ GUP Precision Ground • Small Diameter Face Grooving**

catalogue number	seat size	W	RR	LI	T	KCU10	KCU25	KCP10	KCP25	KCK20	K313	KC5010	KC5025	KY3500	KT315	KB1630	KB5625	KD1405	
A4G0205M2SU02GUP	2S	2,05	0,2	20	2,0	●	●	-	-	-	-	-	-	-	-	-	-	-	-
A4G0305M3SU02GUP	3S	3,05	0,2	20	3,0	●	●	-	-	-	-	-	-	-	-	-	-	-	-
A4G0305M3SU04GUP	3S	3,05	0,4	20	3,0	●	●	-	-	-	-	-	-	-	-	-	-	-	-
A4G0405M4SU04GUP	4S	4,05	0,4	20	3,4	●	●	-	-	-	-	-	-	-	-	-	-	-	-
A4G0505M5SU04GUP	5S	5,05	0,4	25	4,2	●	●	-	-	-	-	-	-	-	-	-	-	-	-
A4G0505M5SU08GUP	5S	5,05	0,8	25	4,2	-	●	-	-	-	-	-	-	-	-	-	-	-	-

NOTE: A4-S inserts are reduced-height A4 inserts. For example, a 2S seat size holder will not accept a seat size 2 insert.

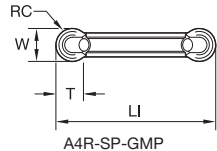
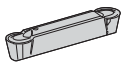

**■ GMP Full Radius Precision Ground • Small Diameter Face Grooving**

catalogue number	seat size	W	RC	LI	T	KCU10	KCU25	KCP10	KCP25	KCK20	K313	KC5010	KC5025	KY3500	KT315	KB1630	KB5625	KD1405	
A4R0200M2SP00GMP	2S	2,00	1,0	20	1,6	-	●	-	-	-	-	-	-	-	-	-	-	-	-
A4R0300M3SP00GMP	3S	3,00	1,5	20	2,5	-	●	-	-	-	-	-	-	-	-	-	-	-	-
A4R0500M5SP00GMP	5S	5,00	2,5	25	4,1	-	●	-	-	-	-	-	-	-	-	-	-	-	-

NOTE: A4-S inserts are reduced-height A4 inserts. For example, a 2S seat size holder will not accept a seat size 2 insert.

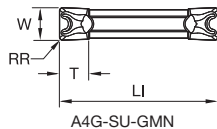
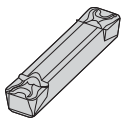

**■ GMN Precision Moulded • Small Diameter Face Grooving**

catalogue number	seat size	W	RR	LI	T	KCU10	KCU25	KCP10	KCP25	KCK20	K313	KC5010	KC5025	KY3500	KT315	KB1630	KB5625	KD1405	
A4G0205M2SU02GMN	2S	2,05	0,2	20	2,0	●	●	-	-	-	-	-	-	-	-	-	-	-	-
A4G0305M3SU02GMN	3S	3,05	0,2	20	3,5	-	●	-	-	-	-	-	-	-	-	-	-	-	-
A4G0305M3SU04GMN	3S	3,05	0,4	20	3,5	●	●	-	-	-	-	-	-	-	-	-	-	-	-
A4G0405M4SU04GMN	4S	4,05	0,4	20	3,6	●	●	-	-	-	-	-	-	-	-	-	-	-	-
A4G0405M4SU08GMN	4S	4,05	0,8	20	3,6	-	●	-	-	-	-	-	-	-	-	-	-	-	-
A4G0505M5SU04GMN	5S	5,05	0,4	25	4,2	●	●	-	-	-	-	-	-	-	-	-	-	-	-

NOTE: A4-S inserts are reduced-height A4 inserts. For example, a 2S seat size holder will not accept a seat size 2 insert.

Grooving and Cut-Off

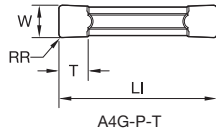
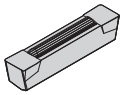

- first choice
- alternate choice

P	●
M	○
K	○
N	○
S	○
H	○

### Flat Top Precision Ground • Ceramic

ISO catalogue number	seat size	W	RR	LI	T	Material
A4G0300M03P04T01025	3	3,00	0,4	20	3,4	●
A4G125I03P1T0425	3	3,18	0,4	20	3,4	●
A4G0400M04P04T01025	4	4,00	0,4	20	3,4	●
A4G0500M05P08T01025	5	5,00	0,8	25	4,2	●
A4G0600M06P08T01025	6	6,00	0,8	30	4,8	●
A4G250I06P2T0425	6	6,35	0,8	30	4,9	●
A4G0800M08P08T01025	8	8,00	0,8	30	6,4	●

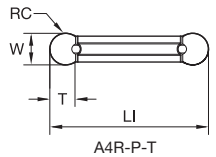
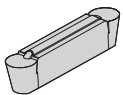

### Flat Top Full Radius Precision Ground • Ceramic

ISO catalogue number	seat size	W	RC	LI	T	Material
A4R0300M03P00T01025	3	3,00	1,5	20	2,4	●
A4R0500M05P00T01025	5	5,00	2,5	25	4,1	●
A4R0600M06P00T01025	6	6,00	3,0	30	4,3	●
A4R250I06P00T0425	6	6,35	3,2	30	4,8	●
A4R0800M08P00T01025	8	8,00	4,0	30	6,4	●

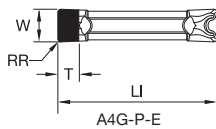
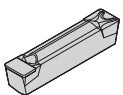

- first choice
- alternate choice

Material	● first choice	○ alternate choice
P	●	○
M	○	○
K	○	○
N	○	○
S	○	○
H	○	○

  

Material	KCU10	KCU25	KCP10	KCP25	KCK20	K313	KC5010	KC5025	KY3500	KT315	KB1630	KB5625	KD1405
P	○	○	○	○	○	○	○	○	○	○	○	○	○
M	○	○	○	○	○	○	○	○	○	○	○	○	○
K	○	○	○	○	○	○	○	○	○	○	○	○	○
N	○	○	○	○	○	○	○	○	○	○	○	○	○
S	○	○	○	○	○	○	○	○	○	○	○	○	○
H	○	○	○	○	○	○	○	○	○	○	○	○	○

### Flat Top Precision Ground • PCD

catalogue number	seat size	W	RR	LI	T	Material
A4G0300M03P04E	3	3,00	0,4	20	3,0	○
A4G0400M04P04E	4	4,00	0,4	20	3,0	○
A4G0500M05P08E	5	5,00	0,8	25	3,0	○



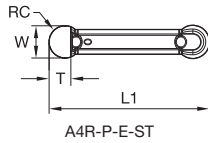
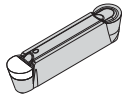

A4R-P-E-ST

■ Flat Top Full Radius Precision Ground • PcBN

● first choice  
○ alternate choice

catalogue number	seat size	W	RC	LI	T	KCU10	KCU25	KCP10	KCP25	KCK20	K313	KC5010	KC5025	KY3500	KT315	KB1630	KB5625	KD1405	
A4R0300M03P00EST	3	3,00	1,5	20	2,2	-	-	-	-	-	-	-	-	-	-	●	-	-	-
A4R0400M04P00EST	4	4,00	2,0	20	2,9	-	-	-	-	-	-	-	-	-	-	●	-	-	-
A4R0500M05P00EST	5	5,00	2,5	25	3,7	-	-	-	-	-	-	-	-	-	-	●	-	-	-
A4R0600M06P00EST	6	6,00	3,0	30	4,4	-	-	-	-	-	-	-	-	-	-	●	-	-	-

P	●	●	●	●	○	○	○	○	○	○	○	○	○	○	○	○	○	○	○
M	●	●	○	○	○	○	○	○	○	○	○	○	○	○	○	○	○	○	○
K	○	○	○	○	○	○	○	○	○	○	○	○	○	○	○	○	○	○	○
N	●	○	○	○	○	○	○	○	○	○	○	○	○	○	○	○	○	○	○
S	●	●	○	○	○	○	○	○	○	○	○	○	○	○	○	○	○	○	○
H	○	○	○	○	○	○	○	○	○	○	○	○	○	○	○	○	○	○	○

A4™ Cut-off Inserts

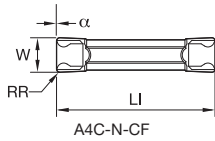
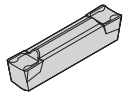

A4C-N-CF

■ CF Precision Moulded • Neutral

● first choice  
○ alternate choice

catalogue number	seat size	W	RR	LI	α	KCU10	KCU25	KCP10	KCP25	KCK20	K313	KC5010	KC5025	KY3500	KT315	KB1630	KB5625	KD1405	
A4C0155N00CF01	1	1,50	0,2	16	—	-	●	-	-	-	-	-	●	-	-	-	-	-	-
A4C0205N00CF02	2	2,05	0,2	20	—	-	●	-	-	-	-	-	●	-	-	-	-	-	-
A4C0255N00CF02	2B	2,50	0,2	20	—	-	●	-	-	-	-	-	●	-	-	-	-	-	-
A4C0305N00CF02	3	3,05	0,2	20	—	-	●	-	-	-	-	-	●	-	-	-	-	-	-
A4C0405N00CF02	4	4,05	0,2	20	—	-	●	-	-	-	-	-	●	-	-	-	-	-	-

P	●	●	●	●	○	○	○	○	○	○	○	○	○	○	○	○	○	○	○
M	●	●	○	○	○	○	○	○	○	○	○	○	○	○	○	○	○	○	○
K	○	○	○	○	○	○	○	○	○	○	○	○	○	○	○	○	○	○	○
N	●	○	○	○	○	○	○	○	○	○	○	○	○	○	○	○	○	○	○
S	●	●	○	○	○	○	○	○	○	○	○	○	○	○	○	○	○	○	○
H	○	○	○	○	○	○	○	○	○	○	○	○	○	○	○	○	○	○	○

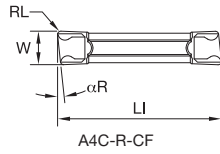
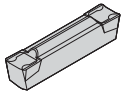

■ CF Precision Moulded • Right Hand

catalogue number	seat size	W	RL	LI	αR	KCU10	KCU25	KCP10	KCP25	KCK20	K313	KC5010	KC5025	KY3500	KT315	KB1630	KB5625	KD1405
A4C0155R06CF01	1	1,50	0,2	16	6.0	-	-	-	-	-	-	-	●	-	-	-	-	-
A4C0155R10CF01	1	1,50	0,2	16	10.0	-	●	-	-	-	-	-	-	-	-	-	-	-
A4C0155R16CF01	1	1,50	0,2	16	16.0	-	-	-	-	-	-	-	●	-	-	-	-	-
A4C0205R06CF02	2	1,99	0,2	20	6.0	-	●	-	-	-	-	-	●	-	-	-	-	-
A4C0205R10CF02	2	1,99	0,2	20	10.0	-	●	-	-	-	-	-	-	-	-	-	-	-
A4C0255R06CF02	2B	2,49	0,2	20	6.0	-	-	-	-	-	-	-	●	-	-	-	-	-
A4C0305R06CF02	3	3,05	0,2	20	6.0	-	●	-	-	-	-	-	●	-	-	-	-	-
A4C0305R10CF02	3	3,05	0,2	20	10.0	-	●	-	-	-	-	-	-	-	-	-	-	-
A4C0405R06CF02	4	4,05	0,2	20	6.0	-	●	-	-	-	-	-	-	-	-	-	-	-
A4C0405R10CF02	4	4,05	0,2	20	10.0	-	●	-	-	-	-	-	●	-	-	-	-	-

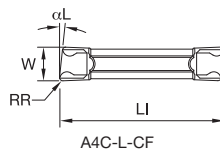
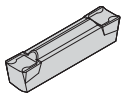

■ CF Precision Moulded • Left Hand

catalogue number	seat size	W	RR	LI	αL	KCU10	KCU25	KCP10	KCP25	KCK20	K313	KC5010	KC5025	KY3500	KT315	KB1630	KB5625	KD1405
A4C0155L06CF01	1	1,50	0,2	16	6.0	-	-	-	-	-	-	-	●	-	-	-	-	-
A4C0205L06CF02	2	1,99	0,2	20	6.0	-	●	-	-	-	-	-	-	-	-	-	-	-
A4C0205L10CF02	2	1,99	0,2	20	10.0	-	-	-	-	-	-	-	●	-	-	-	-	-
A4C0305L06CF02	3	3,05	0,2	20	6.0	-	●	-	-	-	-	-	●	-	-	-	-	-
A4C0305L10CF02	3	3,05	0,2	20	10.0	-	●	-	-	-	-	-	-	-	-	-	-	-
A4C0405L06CF02	4	4,05	0,2	20	6.0	-	●	-	-	-	-	-	-	-	-	-	-	-
A4C0405L10CF02	4	4,05	0,2	20	10.0	-	●	-	-	-	-	-	-	-	-	-	-	-

P	●	●	●	●	○	○	○	○	○	○	○	○	○	○	○	○	○	○	○
M	●	●	○	○	○	○	○	○	○	○	○	○	○	○	○	○	○	○	○
K	○	○	○	○	○	○	○	○	○	○	○	○	○	○	○	○	○	○	○
N	●	○	○	○	○	○	○	○	○	○	○	○	○	○	○	○	○	○	○
S	●	●	○	○	○	○	○	○	○	○	○	○	○	○	○	○	○	○	○
H	○	○	○	○	○	○	○	○	○	○	○	○	○	○	○	○	○	○	○

● first choice  
○ alternate choice





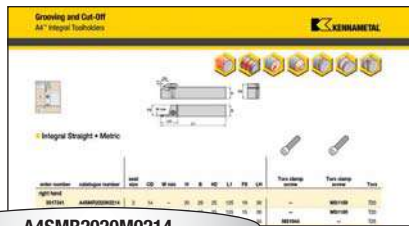

## How Do Catalogue Numbers Work?

Each character in our catalogue number signifies a specific trait of that product. Use the following key columns and corresponding images to easily identify which attributes apply.

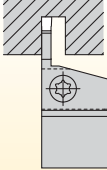

**A4SMR2020M0214**

<b>A4</b>	<b>S</b>	<b>M</b>	<b>R</b>	<b>2020M</b>	<b>02</b>	<b>14</b>
Tooling System	Tool Style	Support Type	Hand of Tool	Shank Size	Seat Size	Max Grooving Depth
<p><b>A4</b> = Grooving and Turning</p>	 <p><b>S</b> = Straight</p>  <p><b>E</b> = End mounted 90°</p>	<p><b>M</b> = Maximum support for specific groove widths and straight clearance for unlimited workpiece diameters</p> <p><b>E</b> = No steel support for face grooving</p> <p><b>C</b> = Reinforced Support</p>	 <p><b>R</b> = Right hand <b>L</b> = Left hand <b>N</b> = Neutral</p>	<p><b>metric:</b> Height x width in mm, letter indicates tool length according to ISO</p> <p><b>metric tool length (mm)</b></p> <p><b>K</b> = 125 <b>M</b> = 150 <b>P</b> = 170</p>	<p><b>02</b> <b>03</b> <b>04</b> <b>05</b> <b>06</b> <b>08</b> <b>10</b></p>	<p>in millimetres</p>

By referencing this easy-to-use guide, you can identify the correct product to meet your needs.



A20RA4EMR0207M

**A**

Steel Bar with Coolant

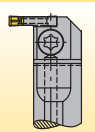

**20**

Bar Diameter

**R**

Bar Length

**A4**

A4™ Groove and Turn System

**E**

Tool Style

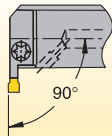

E = End mounted (90°)

**M**

Support Type

**R**

Hand of Tool

**02**

Insert Seat Size

**07**

Grooving Depth in mm

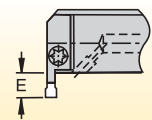

mm  
7mm  
10mm  
12mm  
16mm

**M**

Tool Units

M = Metric

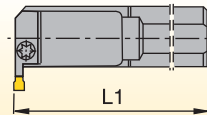

metric bars:

- R = 200mm
- S = 150mm
- T = 300mm

pocket seat size	cutting width (mm)
02	2,00–2,62
2B	2,39–2,62
03	3,0–3,05
04	4,0–4,05
05	5,0–5,05
06	6,0–6,05
08	8,0–8,05
10	10,0–10,05

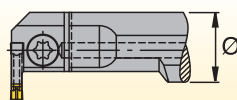

metric bars:

Bar diameter in millimetres

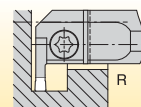

R = Right hand

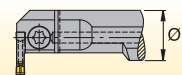

L = Left hand

M = Maximum support

## How Do Catalogue Numbers Work?

Each character in our catalogue number signifies a specific trait of that product. Use the following key columns and corresponding images to easily identify which attributes apply.



<b>KGM</b>	<b>S</b>	<b>L</b>	<b>2525M</b>	<b>50</b>	<b>C</b>
Family Name	Tool Style	Hand	Shank Size	Blade Size	Coolant
Grooving Modular System	<p><b>S</b> = Straight mount</p> <p><b>E</b> = End mount (90°)</p>	<p><b>L</b> = Left hand</p> <p><b>R</b> = Right hand</p>	<p><b>Metric</b> = Height x Width in mm</p> <p>letter indicates tool length according to ISO</p>	<p><b>50</b></p> <p><b>65</b></p>	<p><b>C</b> = Through coolant capable</p>

# Grooving Tools and **Beyond**<sup>™</sup> Inserts for Your Shallow Groove and Turn Operations

## **Top Notch**<sup>™</sup>



Top Notch Grooving is the proven solution for high productivity. The Top Notch system provides consistent tool performance, accurate indexing, and superior clamping to provide excellent surface finishing and superior tool life.

### **FEATURES AND BENEFITS**

- The Beyond PVD coated grades are designed to cut a variety of workpiece materials.
- Rigid clamping securely locks insert in place through the toughest cuts.
- Versatile design enables one system to handle O.D. and I.D. grooving, face grooving, back turning, undercutting, and even threading operations.
- Chip control inserts provide excellent chip evacuation in grooving, and offer better chip control in multidirectional turning.

Experience the advantages at your Authorised Kennametal Distributor or at [kennametal.com](http://kennametal.com).



[kennametal.com](http://kennametal.com)

## How Do Catalogue Numbers Work?

Each character in our catalogue number signifies a specific trait of that product. Use the following key columns and corresponding images to easily identify which attributes apply.

Grooving and Cut-Off  
A4™ Integral Toolholders

Integral Face Grooving • Outboard • Metric

Order number	Catalogue number	Head Size	Blade	Cl. Size	CD	W. Max	FR	Holder Size
280-077	A4M50R0414B048-072	3	38	38	12	3	15.90	30
280-078	A4M50R0414B048-073	3	42	42	12	3	15.90	30
280-079	A4M50R0414B048-074	3	50	50	12	3	15.90	30
280-080	A4M50R0414B048-075	3	60	60	12	3	15.90	30

A4M50R0414B048-072

<p><b>A4M</b></p> <p>Family Name</p> <p>A4 Modular Blade</p>	<p><b>50</b></p> <p>Modular System Size</p> <p>50 65</p>	<p><b>R</b></p> <p>Hand of Tool</p>
--	--	-------------------------------------

By referencing this easy-to-use guide, you can identify the correct product to meet your needs.

order number	catalogue number	seat size	D min	D max	CD	Width	PS	workpiece size
999-999	999-999	999	999	999	999	999	999	999

**A4M50R0414B048-072**

### 04

Seat Size

pocket seat size	cutting width mm
02	2,00–2,62
2B	2,39–2,62
03	3,0–3,05
04	4,0–4,05
05	5,0–5,05
06	6,0–6,05
08	8,0–8,05
10	10,0–10,05

### 14

Maximum Groove Depth

mm

- 14mm
- 19mm
- 20mm
- 26mm

### B

Tool Style

**M** = Maximum support for specific groove widths and straight clearance for unlimited workpiece diameters

**A** = Inboard sweep face grooving toolholder

**B** = Outboard sweep face grooving toolholder

### 048–072

Face Grooving Diameter Range

D min  
D max



diameters are min and max for outer face groove dia.  
999 = unlimited D max

## How Do Catalogue Numbers Work?

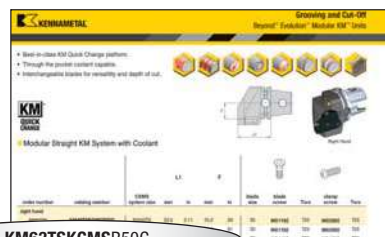
Each character in our catalogue number signifies a specific trait of that product. Use the following key columns and corresponding images to easily identify which attributes apply.

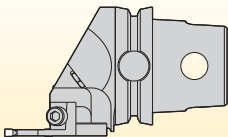

**KM63TSKGMRS50C**

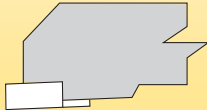
<p><b>KM</b></p>	<p><b>63</b></p>	<p><b>TS</b></p>	<p><b>KGM</b></p>	<p><b>S</b></p>
<p>KM™ Quick-Change</p>	<p>System Size</p>	<p>Feature</p>	<p>Insert Holding Method</p>	<p>Insert Location</p>
<p><b>KM</b> <b>KM4X™</b> <b>PSC</b></p>	<p>40 = 40mm 50 = 50mm 63 = 63mm 80 = 80mm 100 = 100mm</p>	<p><b>TS</b> <b>XMZ</b></p>	<p><b>KGM</b></p>  <p>Modular Grooving</p>	<p>E = End mount S = Side mount</p>  

By referencing this easy-to-use guide, you can identify the correct product to meet your needs.

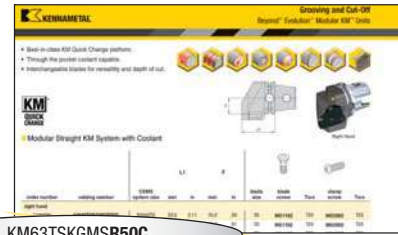

KM63TSKGMSR50C

**R**

Hand of Tool

R = Right hand

L = Left hand

End Mount

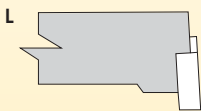
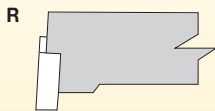

Side Mount

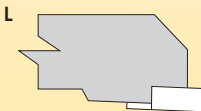
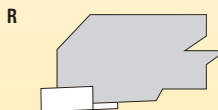

**50**

Blade Size

50

60

**C**

Coolant

C = Through the pocket coolant capable

Special Features

Y = Mazak®  
 INTEGREX®



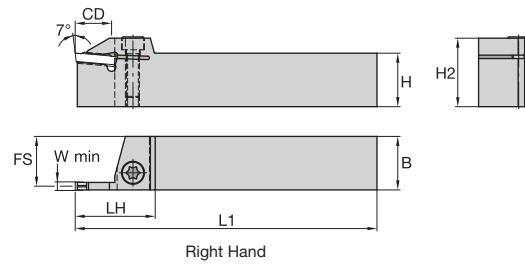
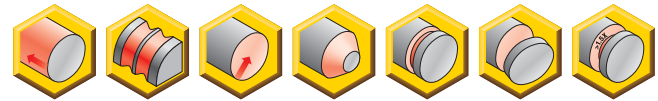
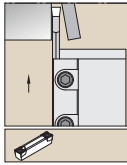

### Integral Straight • Metric



order number	catalogue number	seat size	CD	W min	H	B	H2	L1	FS	LH	clamp screw	clamp screw	Torx
right hand													
3017341	A4SMR2020K0214	2	14	—	20	20	25	125	19	30	—	MS1160	T20
3017342	A4SMR1616K0214	2	14	2	16	16	25	125	15	30	—	MS1160	T20
2974425	A4SMR2020K0217	2	17	2	20	20	31	125	19	34	MS1944	—	T25
3017340	A4SMR2525M0214	2	14	2	25	25	30	150	24	30	—	MS1160	T20
3017339	A4SMR2525M0217	2	17	2	25	25	31	150	24	34	MS1944	—	T25
1949633	A4SMR1616K0314	3	14	3	16	16	27	125	15	35	MS2091	—	T25
2503557	A4SMR2016K0317	3	17	3	20	16	32	125	15	37	MS1970	—	T30
1949635	A4SMR2020K0314	3	14	3	20	20	27	125	19	35	MS1595	—	T30
2503551	A4SMR2020K0317	3	17	3	20	20	32	125	19	37	MS1970	—	T30
1949637	A4SMR2525M0317	3	17	3	25	25	32	150	24	37	MS1970	—	T30
2503559	A4SMR2016K0417	4	17	4	20	16	32	125	14	37	MS1970	—	T30
1949639	A4SMR2020K0414	4	14	4	20	20	27	125	18	35	MS1595	—	T30
2503553	A4SMR2020K0417	4	17	4	20	20	32	125	18	37	MS1970	—	T30
1949641	A4SMR2525M0417	4	17	4	25	25	32	150	23	37	MS1970	—	T30
1949643	A4SMR3225P0417	4	17	4	32	25	40	170	23	37	MS1970	—	T30
1949645	A4SMR2020K0519	5	19	5	20	20	28	125	18	40	MS1595	—	T30
1949647	A4SMR2525M0520	5	20	5	25	25	33	150	23	40	MS1970	—	T30
1949649	A4SMR3225P0522	5	22	5	32	25	40	170	23	42	MS1970	—	T30
2503555	A4SMR2020K0620	6	20	6	20	20	33	125	17	40	MS1970	—	T30
2245484	A4SMR2525M0620	6	20	6	25	25	33	150	22	40	MS1970	—	T30
2263089	A4SMR3225P0626	6	26	6	32	25	40	170	22	45	MS1970	—	T30
2245485	A4SMR2525M0820	8	20	8	25	25	34	150	21	43	MS1490	—	T45
2263091	A4SMR3225P0826	8	26	8	32	25	41	170	21	47	MS1490	—	T45
2263173	A4SMR3225P1026	10	26	10	32	25	41	170	21	47	MS1490	—	T45

(continued)

(Integral Straight • Metric — continued)



order number	catalogue number	seat size	CD	W min	H	B	H2	L1	FS	LH	clamp screw	clamp screw	Torx
<b>left hand</b>													
3017336	A4SML2020K0214	2	14	—	20	20	25	125	19	30	—	MS1160	T20
3017338	A4SML1616K0214	2	14	2	16	16	25	125	15	30	—	MS1160	T20
3017337	A4SML2020K0217	2	17	2	20	20	31	125	19	34	MS1944	—	T25
3017335	A4SML2525M0214	2	14	2	25	25	30	150	24	30	—	MS1160	T20
3017334	A4SML2525M0217	2	17	2	25	25	31	150	24	34	MS1944	—	T25
1949634	A4SML1616K0314	3	14	3	16	16	27	125	15	35	MS2091	—	T25
2503556	A4SML2016K0317	3	17	3	20	16	32	125	15	37	MS1970	—	T30
1949636	A4SML2020K0314	3	14	3	20	20	27	125	19	35	MS1595	—	T30
2503550	A4SML2020K0317	3	17	3	20	20	32	125	19	37	MS1970	—	T30
1949638	A4SML2525M0317	3	17	3	25	25	32	150	24	37	MS1970	—	T30
1949640	A4SML2020K0414	4	14	4	20	20	27	125	18	35	MS1595	—	T30
2503552	A4SML2020K0417	4	17	4	20	20	32	125	18	37	MS1970	—	T30
1949642	A4SML2525M0417	4	17	4	25	25	32	150	23	37	MS1970	—	T30
1949644	A4SML3225P0417	4	17	4	32	25	40	170	23	37	MS1970	—	T30
1949646	A4SML2020K0519	5	19	5	20	20	28	125	18	40	MS1595	—	T30
1949648	A4SML2525M0520	5	20	5	25	25	33	150	23	40	MS1970	—	T30
1949650	A4SML3225P0522	5	22	5	32	25	40	170	23	42	MS1970	—	T30
2503554	A4SML2020K0620	6	20	6	20	20	33	125	17	40	MS1970	—	T30
2245486	A4SML2525M0620	6	20	6	25	25	33	150	22	40	MS1970	—	T30
2263090	A4SML3225P0626	6	26	6	32	25	40	170	22	45	MS1970	—	T30
2245487	A4SML2525M0820	8	20	8	25	25	34	150	21	43	MS1490	—	T45
2263092	A4SML3225P0826	8	26	8	32	25	41	170	21	47	MS1490	—	T45
2263174	A4SML3225P1026	10	26	10	32	25	41	170	21	47	MS1490	—	T45

Grooving and Cut-Off

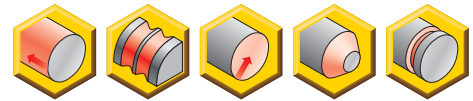
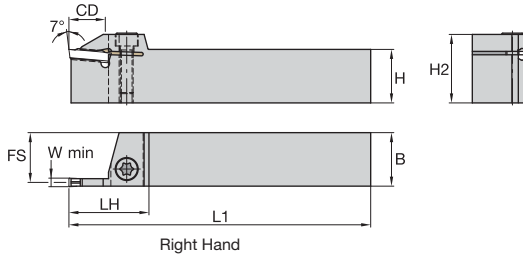
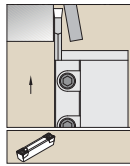

### Integral Straight • Short Projection Toolholders • Metric

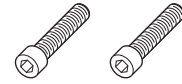

order number	catalogue number	seat size	CD	W min	H	B	H2	L1	FS	LH	clamp screw	clamp screw	Torx
<b>right hand</b>													
3854265	A4SMR2020K0208	2	8	2	20	20	24	125	19	26	—	MS1160	T20
3854267	A4SMR2020K0308	3	8	3	20	20	27	125	19	28	MS1595	—	T30
3854269	A4SMR2020K0408	4	8	4	20	20	27	125	18	28	MS1595	—	T30
3854271	A4SMR2525M0510	5	10	5	25	25	33	150	23	32	MS1970	—	T30
3854273	A4SMR2525M0610	6	10	6	25	25	33	150	22	37	MS1970	—	T30
<b>left hand</b>													
3854266	A4SML2020K0208	2	8	2	20	20	24	125	19	26	—	MS1160	T20
3854268	A4SML2020K0308	3	8	3	20	20	27	125	19	28	MS1595	—	T30
3854270	A4SML2020K0408	4	8	4	20	20	27	125	18	28	MS1595	—	T30
3854272	A4SML2525M0510	5	10	5	25	25	33	150	23	32	MS1970	—	T30
3854274	A4SML2525M0610	6	10	6	25	25	33	150	22	37	MS1970	—	T30

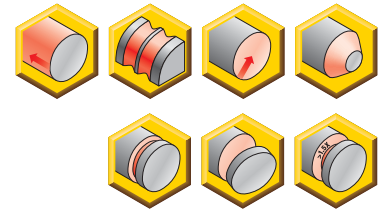
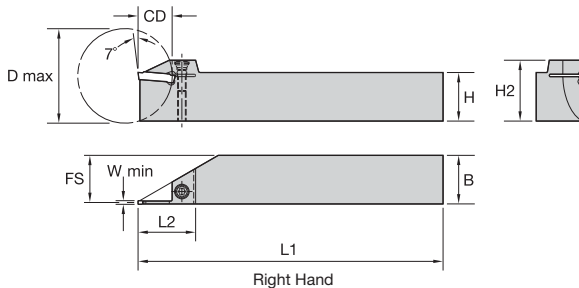
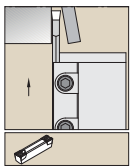

### Integral Straight Top Clamp • Metric

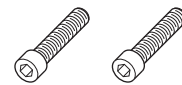

order number	catalogue number	seat size	D max	CD	W min	H	B	H2	L1	FS	LH	clamp screw	clamp screw	wrench size clamp screw
<b>right hand</b>														
2982224	A4SCR1010K0113	1	27	13,500	1,50	10	10	21	125	9,40	25	MS1156	—	T15
2978378	A4SCR1212K0113	1	27	13,500	1,50	12	12	21	125	11,40	25	MS1156	—	T15
2982223	A4SCR1616K0113	1	27	13,500	1,50	16	16	21	125	15,40	25	MS1156	—	T15
2982172	A4SCR2020K0113	1	27	13,500	1,50	20	20	25	125	19,40	25	MS1156	—	T15
4169745	A4SCR1212K0214	2	28	14,000	2,00	12	12	21	125	11,17	28	MS1160	—	T20
4169746	A4SCR1616K0217	2	34	17,000	2,00	16	16	26	125	15,20	31	—	MS1944	T25
4169747	A4SCR1212K0314	3	28	14,000	3,00	12	12	23	125	10,72	30	—	MS2091	25 IP
4169748	A4SCR1616K0317	3	34	17,000	3,00	16	16	27	125	14,72	33	—	MS2091	25 IP
<b>left hand</b>														
2982170	A4SCL1212K0113	1	27	13,500	1,50	12	12	21	125	11,40	25	MS1156	—	T15
2982169	A4SCL1616K0113	1	27	13,500	1,50	16	16	21	125	15,40	25	MS1156	—	T15
2982168	A4SCL2020K0113	1	27	13,500	1,50	20	20	25	125	19,40	25	MS1156	—	T15
4169749	A4SCL1212K0214	2	28	14,000	2,00	12	12	21	125	11,17	28	MS1160	—	T20
4169750	A4SCL1616K0217	2	34	17,000	2,00	16	16	26	125	15,20	31	—	MS1944	T25
4169752	A4SCL1616K0317	3	34	17,000	3,00	16	16	27	125	14,72	33	—	MS2091	25 IP

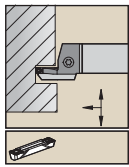

Right hand shown.

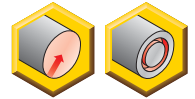
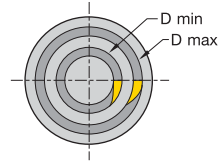
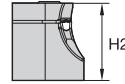
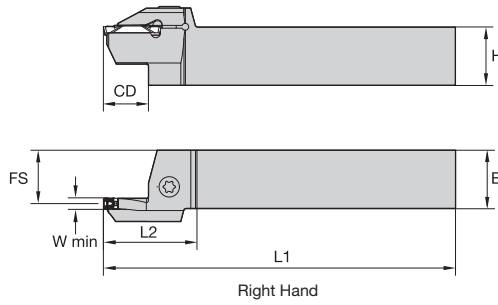

Grooving and Cut-Off

**Integral Face Grooving • Outboard • Metric**

order number	catalogue number	seat size	CD	D min	D max	W min	H	B	H2	L1	FS	LH	clamp screw	Torx
<b>right hand</b>														
3865920	A4SBR2020K2S12016020	2S	12	16	20	2,00	20	20	25	125	19,20	28	—	T20
3865921	A4SBR2020K2S12020025	2S	12	20	25	2,00	20	20	25	125	19,20	28	—	T20
3865922	A4SBR2020K2S12025036	2S	12	25	36	2,00	20	20	25	125	19,20	28	—	T20
3865923	A4SBR2020K3S14020025	3S	14	20	25	3,00	20	20	28	125	18,70	35	MS1595	T30
3865924	A4SBR2020K3S14025036	3S	14	25	36	3,00	20	20	28	125	18,70	35	MS1595	T30
3865926	A4SBR2020K4S14035048	4S	14	35	48	4,00	20	20	28	125	18,20	35	MS1595	T30
3865927	A4SBR2525M5S19028038	5S	19	28	38	5,00	25	25	33	150	22,70	40	MS1970	T30
3865928	A4SBR2525M5S19038058	5S	19	38	58	5,00	25	25	33	150	22,70	40	MS1970	T30
<b>left hand</b>														
3865929	A4SBL2020K2S12016020	2S	12	16	20	2,00	20	20	25	125	19,20	28	—	T20
3865931	A4SBL2020K2S12025036	2S	12	25	36	2,00	20	20	25	125	19,20	28	—	T20
3865932	A4SBL2020K3S14020025	3S	14	20	25	3,00	20	20	28	125	18,70	35	MS1595	T30
3865934	A4SBL2020K4S14025035	4S	14	25	35	4,00	20	20	28	125	18,20	35	MS1595	T30
3865937	A4SBL2525M5S19038058	5S	19	38	58	5,00	25	25	33	150	22,70	40	MS1970	T30

# NOVO KNOWS

## ART TO PART TO PROFIT



Being as productive and profitable as possible is your fundamental goal. With the addition of NOVO™ applications to your team, your goal can be achieved. NOVO applications possess powerful digital tools that link together process planning, inventory availability and purchase, cost-per-part management, and productivity improvements.

NOVO applications can ensure you have the right tools on your machines, in the right sequence. Resulting in flawless execution that accelerates every job, and maximises every shift.

[kennametal.com/novo](http://kennametal.com/novo)

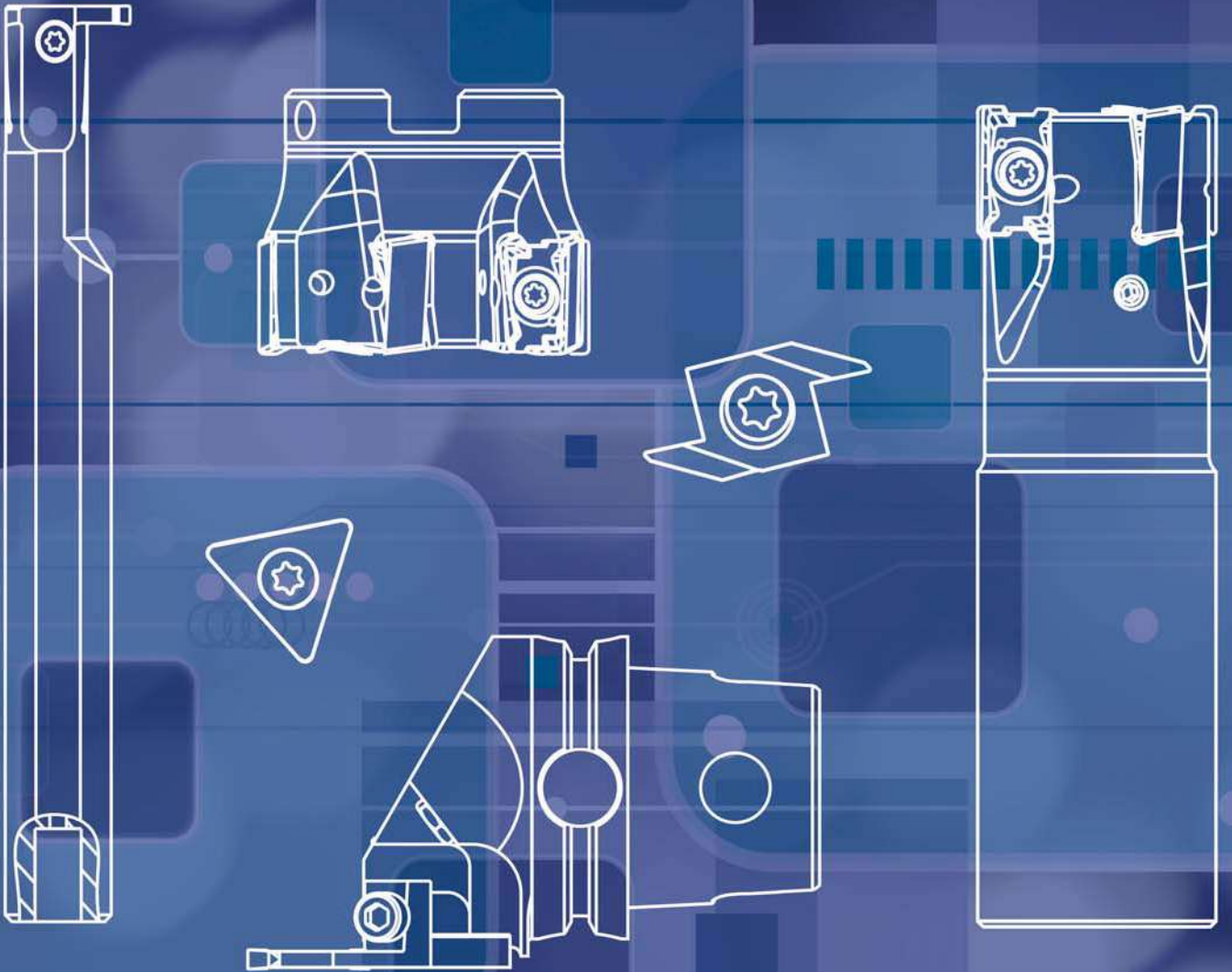

**01**

THE DIGITAL SOURCE FOR DELIVERING  
SMART MACHINING SOLUTIONS

[kennametal.com/novo](http://kennametal.com/novo)

**NOVO**<sup>TM</sup>

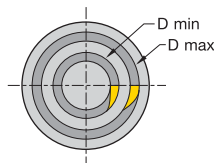
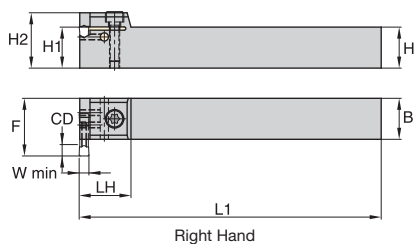
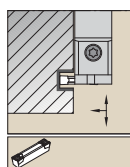

**Integral Face Grooving • End Mount • Dual Handed • Metric**



order number	catalogue number	seat size	CD	W min	D min	H1	B	H2	L1	F	LH	clamp screw	Torx	hex seating screw	hex (mm)
2414136	A4ENN2020K0305	3	5	3,00	70	20	20	27	125,0	25,4	25	MS2091	T25	MS2090	1.5 mm
2414137	A4ENN2525M0305	3	5	3,00	70	25	25	32	150,0	30,4	25	MS2091	T25	MS2090	1.5 mm
1949651	A4ENN2020K0407	4	7	4,00	90	20	20	27	125,0	27,9	25	MS2091	T25	MS2090	1.5 mm
1949652	A4ENN2525M0407	4	7	4,00	90	25	25	32	150,0	33,1	25	MS2091	T25	MS2090	1.5 mm
1949654	A4ENN2525M0509	5	9	5,00	120	25	25	33	150,0	35,1	34	MS1970	T30	193.297	1.5 mm
2503543	A4ENN2020K0611	6	11	6,00	120	20	20	28	125,0	35,4	34	MS1595	T30	193.297	2 mm
2503544	A4ENN2525M0611	6	11	6,00	120	25	25	33	150,0	38,9	34	MS1970	T30	193.297	2 mm
2503545	A4ENN3232P0611	6	11	6,00	120	32	32	40	170,0	43,4	34	MS1970	T30	193.297	2 mm

NOTE: D min for face grooving applications.

A4EN-style toolholders are designed without steel support for face grooving capacity. Cutting feed recommendations should be reduced by 25–30%.

Recommended clamp screw torque, 50–70 in. lbs. (6–8 Nm).

Minimum cutting width supplied for reference only; see insert listing for actual width. Always match seat size of insert to seat size of holder.

**A4EN Insert Mounting**

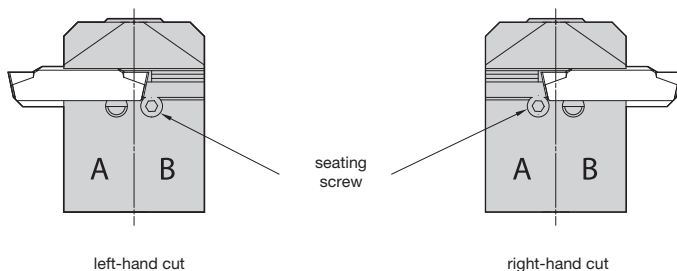

A4EN-style holders can be used for either left- or right-hand applications. The seating screw is to be used in position B for a left-hand cut and in position A for a right-hand cut.

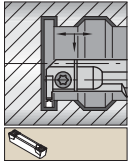

Steel shank with through coolant.

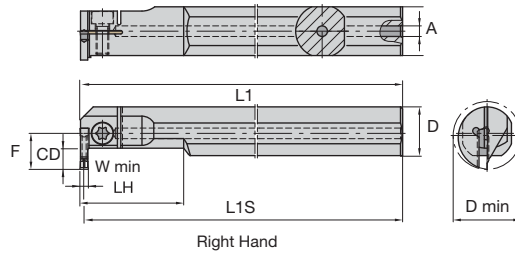

Grooving and Cut-Off

**Steel Boring Bar • Metric**

order number	catalogue number	seat size	CD	W min	D	D min	L1	F	L1S	A	clamp screw	wrench size clamp screw
<b>right hand</b>												
2979223	A20RA4EMR0207M	2	7,00	2,00	20	25	200	13	199,0	4,00	MS2089	25 IP
2979225	A25RA4EMR0210M	2	10,00	2,00	25	32	200	17	199,0	5,00	MS2089	25 IP
1949655	A20RA4EMR0307M	3	7,00	3,00	20	25	200	13	198,5	4,00	MS2089	25 IP
1949657	A25RA4EMR0310M	3	10,00	3,00	25	32	200	17	198,5	5,00	MS1595	T30
1949659	A32SA4EMR0312M	3	12,00	3,00	32	40	250	22	248,5	6,00	MS1595	T30
1949661	A20RA4EMR0407M	4	7,00	4,00	20	25	200	13	198,0	4,00	MS2089	25 IP
1949663	A25RA4EMR0410M	4	10,00	4,00	25	32	200	17	198,0	5,00	MS1595	T30
1949665	A32SA4EMR0412M	4	12,00	4,00	32	40	250	22	248,0	6,00	MS1595	T30
1949667	A40TA4EMR0416M	4	16,00	4,00	40	52	300	30	298,0	6,00	MS1970	T30
1949669	A32SA4EMR0516M	5	16,00	5,00	32	44	250	26	247,5	6,00	MS1595	T30
1949671	A40TA4EMR0516M	5	16,00	5,00	40	52	300	30	297,5	6,00	MS1970	T30
2263197	A40TA4EMR0616M	6	16,00	6,00	40	52	300	30	297,0	6,00	MS1970	T30
<b>left hand</b>												
2979192	A20RA4EML0207M	2	7,00	2,00	20	25	200	13	199,0	4,00	MS2089	25 IP
2979224	A25RA4EML0210M	2	10,00	2,00	25	32	200	17	199,0	5,00	MS2089	25 IP
1949656	A20RA4EML0307M	3	7,00	3,00	20	25	200	13	198,5	4,00	MS2089	25 IP
1949658	A25RA4EML0310M	3	10,00	3,00	25	32	200	17	198,5	5,00	MS1595	T30
1949660	A32SA4EML0312M	3	12,00	3,00	32	40	250	22	248,5	6,00	MS1595	T30
1949662	A20RA4EML0407M	4	7,00	4,00	20	25	200	13	198,0	4,00	MS2089	25 IP
1949664	A25RA4EML0410M	4	10,00	4,00	25	32	200	17	198,0	5,00	MS1595	T30
1949666	A32SA4EML0412M	4	12,00	4,00	32	40	250	22	248,0	6,00	MS1595	T30
1949668	A40TA4EML0416M	4	16,00	4,00	40	52	300	30	298,0	6,00	MS1970	T30
1949670	A32SA4EML0516M	5	16,00	5,00	32	44	250	26	247,5	6,00	MS1595	T30
1949672	A40TA4EML0516M	5	16,00	5,00	40	52	300	30	297,5	6,00	MS1970	T30
2263198	A40TA4EML0616M	6	16,00	6,00	40	52	300	30	297,0	6,00	MS1970	T30



# Grooving and Cut-Off

A4™ Integral Face Grooving Boring Bars



Grooving and Cut-Off

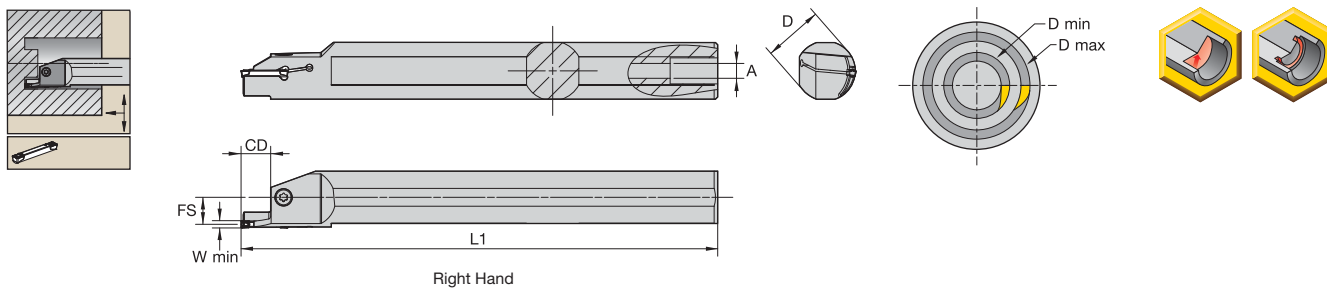

## Steel Face Grooving Boring Bar • Metric



order number	catalogue number	seat size	CD	D min	D max	W min	D	L1	FS	A	clamp screw	wrench size clamp screw
<b>right hand</b>												
3871038	A16RA4SAR2S12M017021	2S	12,00	17	21	2,00	16	201	7	4,00	MS1160	T20
3871039	A20RA4SAR2S12M021026	2S	12,00	21	23	2,00	20	201	9	4,00	MS1160	T20
3871040	A25RA4SAR2S12M026036	2S	12,00	26	36	2,00	25	201	12	6,35	MS1160	T20
3871041	A20RA4SAR3S14M021026	3S	14,00	21	26	3,00	20	201	9	4,00	MS1160	T20
3871042	A25RA4SAR3S14M026036	3S	14,00	26	36	3,00	25	201	11	6,35	MS1160	T20
<b>left hand</b>												
3871033	A16RA4SAL2S12M017021	2S	12,00	17	21	2,00	16	201	7	4,00	MS1160	T20
3871034	A20RA4SAL2S12M021026	2S	12,00	21	26	2,00	20	201	9	4,00	MS1160	T20
3871035	A25RA4SAL2S12M026036	2S	12,00	26	36	2,00	25	201	12	6,35	MS1160	T20
3871037	A25RA4SAL3S14M026036	3S	14,00	26	36	3,00	25	201	11	6,35	MS1160	T20

Precision Ground Insert  
Programme Goes Above  
and Beyond!

# Fix-Perfect™

The breakthrough performance characteristics of these precision ground inserts enable outstanding indexing accuracy and excellent chip flow when machining steel, cast iron, and stainless steel workpiece materials. Fix-Perfect Beyond™ inserts are the ideal solution to machining operations in a multitude of industries, including fluid power, energy, automotive, heavy equipment, and general engineering applications.



Experience the advantages at your Authorised Kennametal  
Distributor or at [kennametal.com](http://kennametal.com).



[kennametal.com](http://kennametal.com)

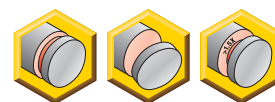
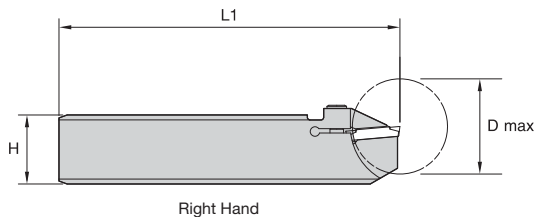
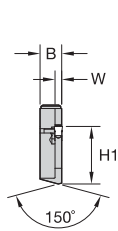
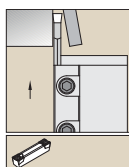

### Single-Ended Cut-Off Blade • Metric



order number	catalogue number	seat size	H	W	H1	L1	B	D max	clamp screw	Torx
<b>right hand</b>										
3967127	A4BHCL26K0317R	3	26	3,0	21,4	125	7,95	35	MS1571	T20
3967124	A4BHCL32K0317R	3	32	3,0	25,0	125	7,95	35	MS1571	T20
3967117	A4BHCR32K0217R	2	32	2,0	25,0	125	7,95	35	MS1571	T20
<b>left hand</b>										
3967136	A4BHCL32K0217L	2	32	2,0	25,0	125	7,95	35	MS1571	T20
3967137	A4BHCL32K0317L	3	32	3,0	25,0	125	7,95	35	MS1571	T20
3967134	A4BHCR26K0317L	3	26	3,0	21,4	125	7,95	35	MS1571	T20

NOTE: Seat size 1 blades only.  
 Assembly wrenches 170.137 and 170.130 must be ordered separately.

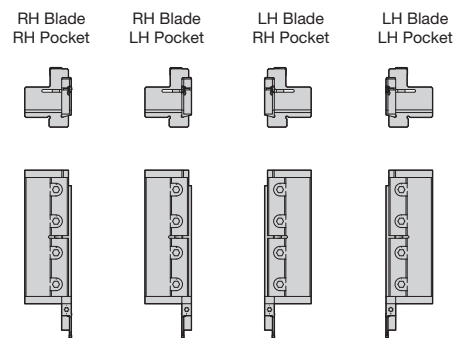

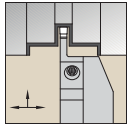

Right hand shown

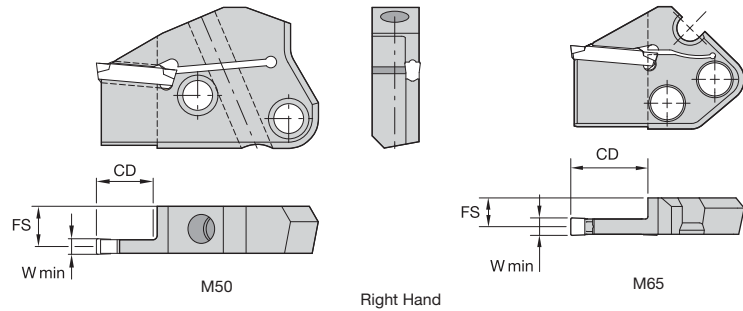
**Modular Straight Blade with Coolant**

order number	catalogue number	seat size	CD	FS	blade size
<b>right hand</b>					
6401815	A4M50R0314MC	3	14,0	10,42	50
6401817	A4M50R0414MC	4	14,0	9,92	50
6401819	A4M50R0519MC	5	19,0	9,42	50
6401834	A4M65R0620MC	6	20,0	9,88	65
6401838	A4M65R0820MC	8	20,0	9,00	65
6401852	A4M65R1020MC	10	20,0	8,35	65
6401831	A4M65R0522MC	5	22,0	10,28	65
6401835	A4M65R0626MC	6	26,0	9,88	65
6401839	A4M65R0826MC	8	26,0	9,00	65
6401853	A4M65R1026MC	10	26,0	8,35	65
<b>left hand</b>					
6401814	A4M50L0314MC	3	14,0	10,42	50
6401816	A4M50L0414MC	4	14,0	9,92	50
6401818	A4M50L0519MC	5	19,0	9,43	50
6401832	A4M65L0620MC	6	20,0	9,88	65
6401836	A4M65L0820MC	8	20,0	9,00	65
6401840	A4M65L1020MC	10	20,0	8,35	65
6401820	A4M65L0522MC	5	22,0	10,28	65
6401833	A4M65L0626MC	6	26,0	9,88	65
6401837	A4M65L0826MC	8	26,0	9,00	65
6401851	A4M65L1026MC	10	26,0	8,35	65

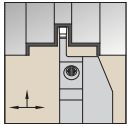

Right hand shown.



Grooving and Cut-Off

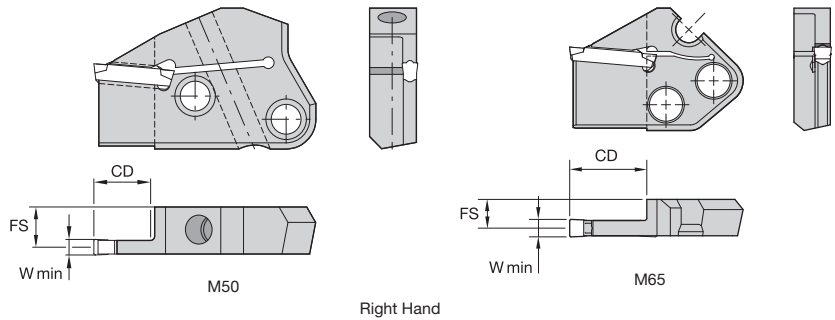

### Modular Straight Blade

order number	catalogue number	seat size	W min	CD	FS	blade size
<b>right hand</b>						
3051624	A4M50R0214M	2	2,00	14,0	10,87	50
1989348	A4M50R0314M	3	3,00	14,0	10,43	50
1989350	A4M50R0414M	4	4,00	14,0	9,93	50
1989352	A4M50R0519M	5	5,00	19,0	9,43	50
3557114	A4M65R0620M	6	6,00	20,0	9,88	65
3557116	A4M65R0626M	6	6,00	26,0	9,88	65
3557120	A4M65R0826M	8	8,00	26,0	9,00	65
3557124	A4M65R1026M	10	10,00	26,0	8,35	65
<b>left hand</b>						
3022625	A4M50L0214M	2	2,00	14,0	10,87	50
1989347	A4M50L0314M	3	3,00	14,0	10,43	50
1989349	A4M50L0414M	4	4,00	14,0	9,93	50
3051623	A4M50L2B14M	2B	2,50	14,0	10,70	50
1989351	A4M50L0519M	5	5,00	19,0	9,43	50
3557115	A4M65L0620M	6	6,00	20,0	9,88	65
3557119	A4M65L0820M	8	8,00	20,0	9,00	65
3557123	A4M65L1020M	10	10,00	20,0	8,35	65
3557117	A4M65L0626M	6	6,00	26,0	9,88	65
3557121	A4M65L0826M	8	8,00	26,0	9,00	65
3557125	A4M65L1026M	10	10,00	26,0	8,35	65

NOTE: Seat size 2B only accepts 2B inserts. Seat size 2 accepts 2 or 2B inserts.

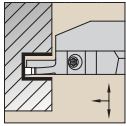

Right hand shown.

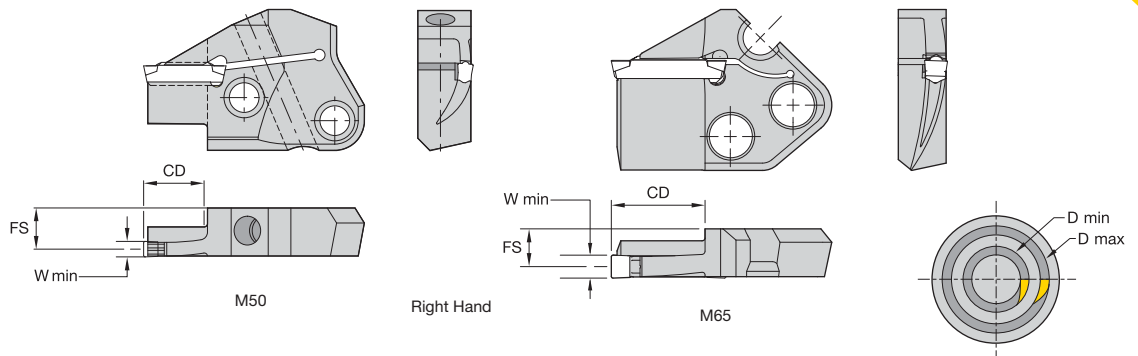
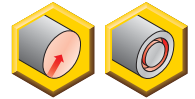

Grooving and Cut-Off

■ Modular Face Grooving Blade • Inboard

order number	catalogue number	seat size	D min	D max	cartridge size
<b>right hand</b>					
3051670	A4M50R0212A036046	2	36	46	50
3051671	A4M50R0212A042054	2	42	54	50
3051672	A4M50R0212A050064	2	50	64	50
3051673	A4M50R0212A060084	2	60	84	50
3051674	A4M50R0212A080124	2	80	124	50
3051675	A4M50R0212A120254	2	120	254	50
3051676	A4M50R0212A250999	2	250	—	50
2542517	A4M50R0314A036048	3	36	48	50
2542518	A4M50R0314A042058	3	42	58	50
2542519	A4M50R0314A052074	3	52	74	50
2542520	A4M50R0314A068100	3	68	100	50
2542521	A4M50R0314A090160	3	90	160	50
2542522	A4M50R0314A130300	3	130	300	50
2542523	A4M50R0314A290999	3	290	—	50
2542531	A4M50R0414A048072	4	48	72	50
2542532	A4M50R0414A064100	4	64	100	50
2542533	A4M50R0414A092150	4	92	150	50
2542534	A4M50R0414A132300	4	132	300	50
2542535	A4M50R0414A290999	4	290	—	50
2542541	A4M50R0519A058094	5	58	94	50
2542542	A4M50R0519A080136	5	80	136	50
2542543	A4M50R0519A120300	5	120	300	50
2542544	A4M50R0519A250999	5	250	—	50
3557131	A4M65R0624A070-112	6	70	112	65
3557163	A4M65R0624A100-212	6	100	212	65
3557165	A4M65R0624A200-999	6	200	999	65
3557167	A4M65R0824A090-200	8	90	200	65
3557169	A4M65R0824A184-999	8	184	999	65
3557173	A4M65R1024A200-999	10	200	999	65

(continued)

(Modular Face Grooving Blade • Inboard — continued)

order number	catalogue number	seat size	D min	D max	cartridge size
<b>left hand</b>					
3051629	A4M50L0212A060084	2	60	84	50
3051631	A4M50L0212A120254	2	120	254	50
3051632	A4M50L0212A250999	2	250	—	50
2542524	A4M50L0314A036048	3	36	48	50
2542527	A4M50L0314A068100	3	68	100	50
2542528	A4M50L0314A090160	3	90	160	50
2542529	A4M50L0314A130300	3	130	300	50
2542530	A4M50L0314A290999	3	290	—	50
2542537	A4M50L0414A064100	4	64	100	50
2542538	A4M50L0414A092150	4	92	150	50
2542539	A4M50L0414A132300	4	132	300	50
2542540	A4M50L0414A290999	4	290	—	50
2542545	A4M50L0519A058094	5	58	94	50
2542546	A4M50L0519A080136	5	80	136	50
2542547	A4M50L0519A120300	5	120	300	50
2542548	A4M50L0519A250999	5	250	—	50
3557132	A4M65L0624A070-112	6	70	112	65
3557164	A4M65L0624A100-212	6	100	212	65
3557166	A4M65L0624A200-999	6	200	999	65
3557174	A4M65L1024A200-999	10	200	999	65



Right hand shown.

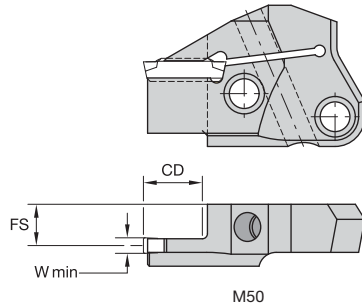

M50

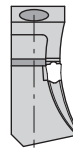

Right Hand

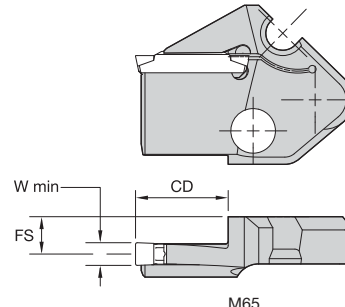

M65

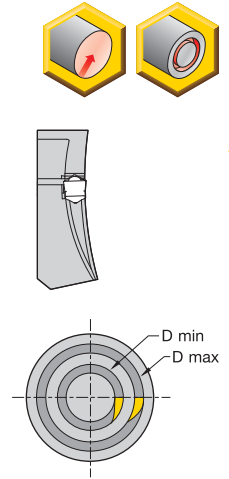
**■ Modular Face Grooving Blade • Outboard**

order number	catalogue number	seat size	D min	D max	CD	FS	cartridge size
<b>right hand</b>							
3051677	A4M50R0212B036046	2	36	46	12,00	10,900	50
3051678	A4M50R0212B042054	2	42	54	12,00	10,900	50
3051679	A4M50R0212B050064	2	50	64	12,00	10,900	50
3051680	A4M50R0212B060084	2	60	84	12,00	10,900	50
3051681	A4M50R0212B080124	2	80	124	12,00	10,900	50
3051682	A4M50R0212B120254	2	120	254	12,00	10,900	50
3051683	A4M50R0212B250999	2	250	—	12,00	10,900	50
3867457	A4M50R2S12B016020	2S	16	20	12,00	10,900	50
3867458	A4M50R2S12B020025	2S	20	25	12,00	10,900	50
3867459	A4M50R2S12B025036	2S	25	36	12,00	10,900	50
2398751	A4M50R0314B036048	3	36	48	14,00	10,500	50
2398752	A4M50R0314B042058	3	42	58	14,00	10,500	50
2398763	A4M50R0314B052074	3	52	74	14,00	10,500	50
2398764	A4M50R0314B068100	3	68	100	14,00	10,500	50
2398765	A4M50R0314B090160	3	90	160	14,00	10,500	50
2398766	A4M50R0314B130300	3	130	300	14,00	10,500	50
2398767	A4M50R0314B290999	3	290	—	14,00	10,500	50
2398775	A4M50R0414B048072	4	48	72	14,00	10,000	50
2398776	A4M50R0414B064100	4	64	100	14,00	10,000	50
2398777	A4M50R0414B092150	4	92	150	14,00	10,000	50
2398778	A4M50R0414B132300	4	132	300	14,00	10,000	50
2398779	A4M50R0414B290999	4	290	—	14,00	10,000	50
3867460	A4M50R3S14B020025	3S	20	25	14,00	10,490	50
3867461	A4M50R3S14B025036	3S	25	36	14,00	10,490	50
3867462	A4M50R4S14B025035	4S	25	35	14,00	10,000	50
3867464	A4M50R5S17B028038	5S	28	38	17,00	9,500	50
2398785	A4M50R0519B058094	5	58	94	19,00	9,500	50
2398786	A4M50R0519B080136	5	80	136	19,00	9,500	50
2398787	A4M50R0519B120300	5	120	300	19,00	9,500	50
2398788	A4M50R0519B250999	5	250	—	19,00	9,500	50
3557175	A4M65R0624B070-112	6	70	112	24,00	9,870	65
3557177	A4M65R0624B100-212	6	100	212	24,00	9,870	65
3557179	A4M65R0624B200-999	6	200	999	24,00	9,870	65
3557181	A4M65R0824B090-200	8	90	200	24,00	9,000	65
3557193	A4M65R0824B184-999	8	184	999	24,00	9,000	65
3557195	A4M65R1024B100-220	10	100	220	24,00	8,350	65
3557197	A4M65R1024B200-999	10	200	999	24,00	8,350	65

(continued)



(Modular Face Grooving Blade • Outboard – continued)

Grooving and Cut-Off

order number	catalogue number	seat size	D min	D max	CD	FS	cartridge size
<b>left hand</b>							
3051663	A4M50L0212B036046	2	36	46	12,00	10,900	50
3051664	A4M50L0212B042054	2	42	54	12,00	10,900	50
3051665	A4M50L0212B050064	2	50	64	12,00	10,900	50
3051666	A4M50L0212B060084	2	60	84	12,00	10,900	50
3051667	A4M50L0212B080124	2	80	124	12,00	10,900	50
3051668	A4M50L0212B120254	2	120	254	12,00	10,900	50
3867466	A4M50L2S12B016020	2S	16	20	12,00	10,900	50
3867467	A4M50L2S12B020025	2S	20	25	12,00	10,900	50
3867468	A4M50L2S12B025036	2S	25	36	12,00	10,900	50
2398768	A4M50L0314B036048	3	36	48	14,00	10,500	50
2398769	A4M50L0314B042058	3	42	58	14,00	10,500	50
2398770	A4M50L0314B052074	3	52	74	14,00	10,500	50
2398771	A4M50L0314B068100	3	68	100	14,00	10,500	50
2398772	A4M50L0314B090160	3	90	160	14,00	10,500	50
2398773	A4M50L0314B130300	3	130	300	14,00	10,500	50
2398774	A4M50L0314B290999	3	290	—	14,00	10,500	50
2398780	A4M50L0414B048072	4	48	72	14,00	10,000	50
2398781	A4M50L0414B064100	4	64	100	14,00	10,000	50
2398782	A4M50L0414B092150	4	92	150	14,00	10,000	50
2398783	A4M50L0414B132300	4	132	300	14,00	10,000	50
2398784	A4M50L0414B290999	4	290	—	14,00	10,000	50
3867469	A4M50L3S14B020025	3S	20	25	14,00	10,490	50
3867470	A4M50L3S14B025036	3S	25	36	14,00	10,490	50
3867472	A4M50L4S14B035048	4S	35	48	14,00	10,000	50
3867484	A4M50L5S17B028038	5S	28	38	17,00	9,500	50
2398789	A4M50L0519B058094	5	58	94	19,00	9,500	50
2398790	A4M50L0519B080136	5	80	136	19,00	9,500	50
2398791	A4M50L0519B120300	5	120	300	19,00	9,500	50
2398792	A4M50L0519B250999	5	250	—	19,00	9,500	50
3557176	A4M65L0624B070-112	6	70	112	24,00	9,870	65
3557178	A4M65L0624B100-212	6	100	212	24,00	9,870	65
3557180	A4M65L0624B200-999	6	200	999	24,00	9,870	65
3557182	A4M65L0824B090-200	8	90	200	24,00	9,000	65
3557194	A4M65L0824B184-999	8	184	999	24,00	9,000	65
3557198	A4M65L1024B200-999	10	200	999	24,00	8,350	65

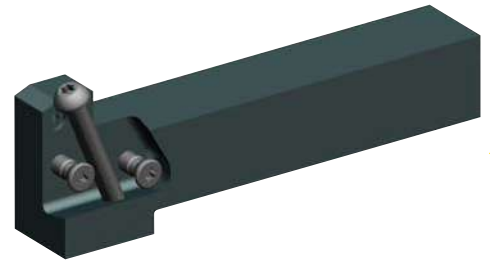
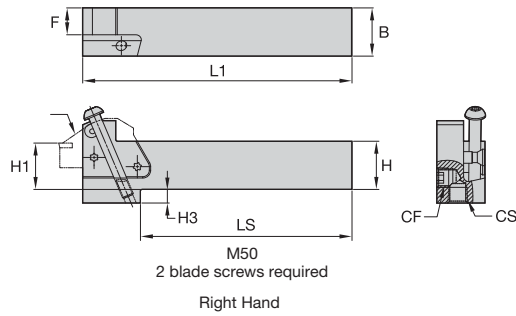

Grooving and Cut-Off

■ Modular Straight Toolholder • Metric

**NOTE:** For modular straight toolholder with coolant, see page C58.



order number	catalogue number	B	H	L1	F	LS	H3	blade screw	Torx	clamp screw	Torx
<b>right hand</b>											
1600249	KGMSR2525M50	25	25	138,75	13,84	109,00	7,00	MS1162	T25	MS2002	T25
3553429	KGMSR2525M65	25	25	150,00	13,00	120,00	14,00	MS1163	T30	—	—
1621083	KGMSR3232P50	32	32	158,75	20,81	—	—	MS1162	T25	MS2002	T25
3553431	KGMSR3232P65	32	32	170,00	20,79	158,00	7,00	MS1163	T30	—	—
<b>left hand</b>											
1600250	KGMSL2525M50	25	25	138,75	13,84	109,00	7,00	MS1162	T25	MS2002	T25
3553430	KGMSL2525M65	25	25	150,00	13,00	120,00	14,00	MS1163	T30	—	—
1621084	KGMSL3232P50	32	32	158,75	20,81	—	—	MS1162	T25	MS2002	T25
3553432	KGMSL3232P65	32	32	170,00	20,79	158,00	7,00	MS1163	T30	—	—

NOTE: KGMS.: Right-hand holder uses right-hand blades.  
 KGME.: Right-hand holder uses left-hand blades.  
 M50 blade and clamp screw torque equals 8–10 Nm (71–88 in. lbs.).  
 M65 blade and clamp screw torque equals 18–20 Nm (159–177 in. lbs.).

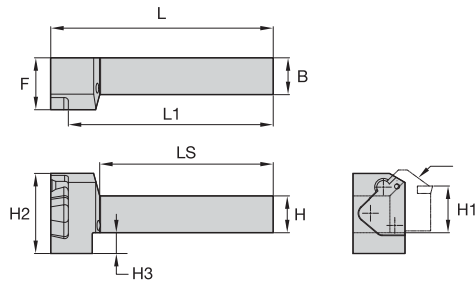

M65  
2 blade screws required  
Right Hand

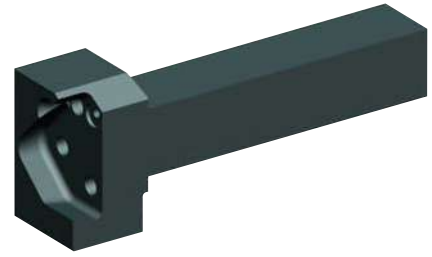

Grooving and Cut-Off

### Modular End Mount Toolholders • Metric

**NOTE:** For modular end mount toolholder with coolant, see page C59.



order number	catalogue number	B	H	L1	F	LS	H3	L	blade screw (2 required)	Torx	clamp screw	Torx
<b>right hand</b>												
1600270	KGMER2525M50	25	25	139,25	42,75	125,25	6,84	150,25	MS1162	T25	MS2002	T25
3553453	KGMER2525M65	25	25	138,15	35,00	129,00	14,00	150,00	MS1163	T30	—	—
1621085	KGMER3232P50	32	32	159,25	42,75	145,25	—	170,25	MS1162	T25	MS2002	T25
3553455	KGMER3232P65	32	32	158,15	35,00	153,00	7,00	170,00	MS1163	T30	—	—
<b>left hand</b>												
1600271	KGME2525M50	25	25	139,25	42,75	125,25	6,84	150,25	MS1162	T25	MS2002	T25
3553454	KGME2525M65	25	25	138,15	35,00	129,00	14,00	150,00	MS1163	T30	—	—
1621086	KGME3232P50	32	32	159,25	42,75	145,25	—	170,25	MS1162	T25	MS2002	T25
3553456	KGME3232P65	32	32	158,15	35,00	153,00	7,00	170,00	MS1163	T30	—	—

NOTE: KGMS.: Right-hand holder uses right-hand blades.  
 KGME.: Right-hand holder uses left-hand blades.  
 M50 blade and clamp screw torque equals 8–10 Nm (71–88 in. lbs.).  
 M65 blade and clamp screw torque equals 18–20 Nm (159–177 in. lbs.).

- Best-in-class KM Quick-Change platform.
- Through the pocket coolant capable.
- Interchangeable blades for versatility and depth of cut.

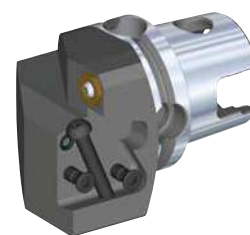
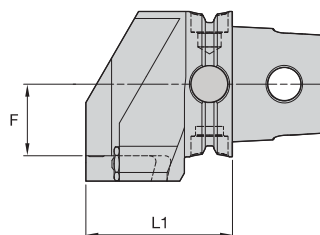
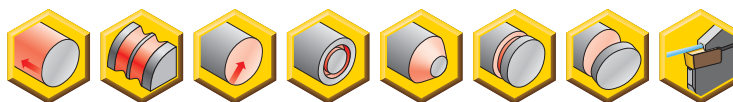

Right Hand

Grooving and Cut-Off

## ■ Modular Straight KM System with Coolant



order number	catalogue number	CSMS system size	L1	F	blade size	blade screw	Torx	clamp screw	Torx
<b>right hand</b>									
5999790	KM40TSKGMSR50C	KM40TS	53,5	15,0	50	MS1162	T25	MS2002	T25
6000422	KM50TSKGMSR65C	KM50TS	53,5	22,0	65	MS1163	T30	—	—
5999864	KM50TSKGMSR50C	KM50TS	58,5	23,0	50	MS1162	T25	MS2002	T25
6000431	KM63TSKGMSR65C	KM63TS	58,5	30,0	65	MS1163	T30	—	—
5999948	KM63TSKGMSR50C	KM63TS	63,5	31,0	50	MS1162	T25	MS2002	T25
5999972	KM63XMZKGMSR50CY	KM63XMZ	63,5	31,0	50	MS1162	T25	MS2002	T25
6017695	KM80TSKGMSR65C	KM80TS	63,5	40,0	65	MS1163	T30	—	—
6000018	KM80ATCKGMSR50C	KM80ATC	66,5	41,0	50	MS1162	T25	MS2002	T25
6000014	KM80TSKGMSR50C	KM80TS	66,5	41,0	50	MS1162	T25	MS2002	T25
<b>left hand</b>									
5999861	KM40TSKGMSL50C	KM40TS	53,5	15,0	50	MS1162	T25	MS2002	T25
6000424	KM50TSKGMSL65C	KM50TS	53,5	22,0	65	MS1163	T30	—	—
5999865	KM50TSKGMSL50C	KM50TS	58,5	23,0	50	MS1162	T25	MS2002	T25
6000433	KM63TSKGMSL65C	KM63TS	58,5	30,0	65	MS1163	T30	—	—
5999949	KM63TSKGMSL50C	KM63TS	63,5	31,0	50	MS1162	T25	MS2002	T25
5999973	KM63XMZKGMSLF50CY	KM63XMZ	63,5	31,0	50	MS1162	T25	MS2002	T25
6017696	KM80TSKGMSL65C	KM80TS	63,5	40,0	65	MS1163	T30	—	—
6000019	KM80ATCKGMSL50C	KM80ATC	66,5	41,0	50	MS1162	T25	MS2002	T25
6000015	KM80TSKGMSL50C	KM80TS	66,5	41,0	50	MS1162	T25	MS2002	T25

NOTE: KGMS... Right-hand holder uses right-hand blades.  
 KGME... Right-hand holder uses left-hand blades.  
 M50 blade and clamp screw torque equals 8–10 Nm (71–88 in. lbs.).  
 M65 blade and clamp screw torque equals 18–20 Nm (159–177 in. lbs.).

- Best-in-class KM Quick-Change platform.
- Through the pocket coolant capable.
- Interchangeable blades for versatility and depth of cut.

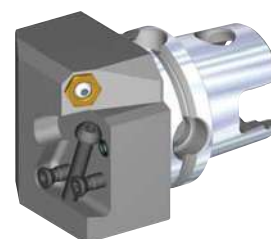
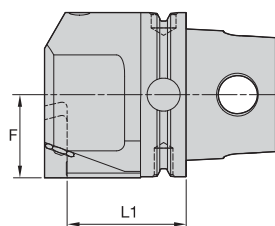
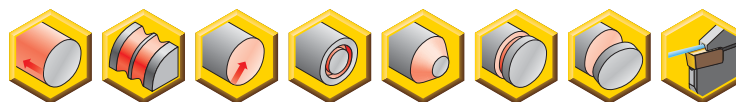

Right Hand



### Modular End Mount KM System with Coolant • Metric



order number	catalogue number	CSMS system size	L1	F	blade size	blade screw	Torx	clamp screw	Torx
<b>right hand</b>									
5999788	KM40TSKGMER50C	KM40TS	28,0	20,50	50	MS1162	T25	MS2002	T25
5999862	KM50TSKGMER50C	KM50TS	38,0	25,50	50	MS1162	T25	MS2002	T25
6000410	KM50TSKGMER65C	KM50TS	47,0	25,50	65	MS1163	T30	—	—
6000425	KM63TSKGMER65C	KM63TS	47,0	32,52	65	MS1163	T30	—	—
5999946	KM63TSKGMER50C	KM63TS	48,0	32,50	50	MS1162	T25	MS2002	T25
6000434	KM63XMZKGMER65CY	KM63XMZ	47,0	32,50	65	MS1163	T30	—	—
5999950	KM63XMZKGMER50CY	KM63XMZ	48,0	32,50	50	MS1162	T25	MS2002	T25
6017697	KM80ATCKGMER65C	KM80ATC	57,0	40,50	65	MS1163	T30	—	—
6000016	KM80ATCKGMER50C	KM80ATC	58,0	40,50	50	MS1162	T25	MS2002	T25
6017693	KM80TSKGMER65C	KM80TS	57,0	40,50	65	MS1163	T30	—	—
6000012	KM80TSKGMER50C	KM80TS	58,0	40,50	50	MS1162	T25	MS2002	T25
<b>left hand</b>									
5999789	KM40TSKGMEL50C	KM40TS	28,0	20,50	50	MS1162	T25	MS2002	T25
5999863	KM50TSKGMEL50C	KM50TS	38,0	25,50	50	MS1162	T25	MS2002	T25
6000421	KM50TSKGMEL65C	KM50TS	47,0	25,50	65	MS1163	T30	—	—
6000430	KM63TSKGMEL65C	KM63TS	47,0	32,52	65	MS1163	T30	—	—
5999947	KM63TSKGMEL50C	KM63TS	48,0	32,50	50	MS1162	T25	MS2002	T25
6000436	KM63XMZKGMELF65CY	KM63XMZ	47,0	32,50	65	MS1163	T30	—	—
5999971	KM63XMZKGMELF50CY	KM63XMZ	48,0	32,50	50	MS1162	T25	MS2002	T25
6017698	KM80ATCKGMEL65C	KM80ATC	57,0	40,50	65	MS1163	T30	—	—
6000017	KM80ATCKGMEL50C	KM80ATC	58,0	40,50	50	MS1162	T25	MS2002	T25
6017694	KM80TSKGMEL65C	KM80TS	57,0	40,50	65	MS1163	T30	—	—
6000013	KM80TSKGMEL50C	KM80TS	58,0	40,50	50	MS1162	T25	MS2002	T25

NOTE: KGMS... Right-hand holder uses right-hand blades.  
 KGME... Right-hand holder uses left-hand blades.  
 M50 blade and clamp screw torque equals 8–10 Nm (71–88 in. lbs.).  
 M65 blade and clamp screw torque equals 18–20 Nm (159–177 in. lbs.).

- Through the pocket coolant capable.
- Interchangeable blades for versatility and depth of cut.

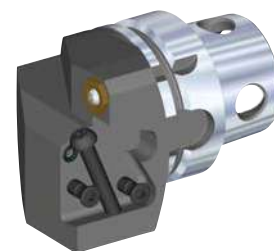
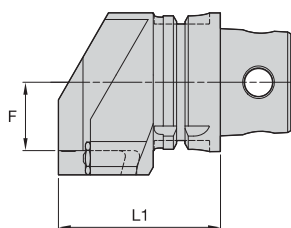
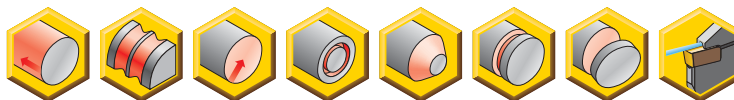

Right Hand

Grooving and Cut-Off

### ■ Modular Straight KM4X™ System with Coolant



order number	catalogue number	CSMS system size	L1	F	blade size	blade screw	Torx	clamp screw	Torx
<b>right hand</b>									
5543560	KM4X63KGMSR65C	KM4X63	68,5	30,0	65	MS1163	T30	—	—
6000407	KM4X63KGMSR50C	KM4X63	73,5	31,0	50	MS1162	T25	MS2002	T25
<b>left hand</b>									
5543558	KM4X63KGMSL65C	KM4X63	68,5	30,0	65	MS1163	T30	—	—
6000408	KM4X63KGMSL50C	KM4X63	73,5	31,0	50	MS1162	T25	MS2002	T25

NOTE: KGMS.: Right-hand holder uses right-hand blades.  
 KGME.: Right-hand holder uses left-hand blades.  
 M50 blade and clamp screw torque equals 8–10 Nm (71–88 in. lbs.).  
 M65 blade and clamp screw torque equals 18–20 Nm (159–177 in. lbs.).

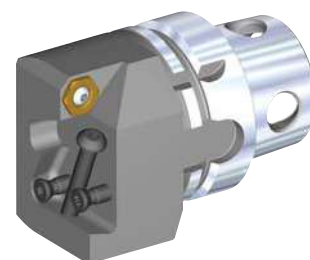
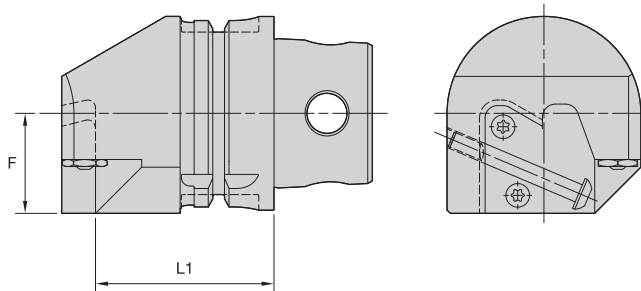

Right Hand

### ■ Modular End Mount KM4X™ System with Coolant



order number	catalogue number	CSMS system size	L1	F	cartridge size	blade screw	nozzle	clamp screw	kg	lbs
<b>right hand</b>										
5543555	KM4X63KGMER65C	KM4X63	57,0	32,5	65	MS1163	PMT04525	—	1,87	4.13
6000404	KM4X63KGMER50C	KM4X63	58,0	32,5	50	MS1162	PMT04525	MS2002	1,85	4.08
6000407	KM4X63KGMSR50C	KM4X63	73,5	31,0	50	MS1162	PMT04525	MS2002	1,86	4.11
<b>left hand</b>										
5543553	KM4X63KGME65C	KM4X63	57,0	32,5	65	MS1163	PMT04525	—	1,87	4.13
6000405	KM4X63KGME50C	KM4X63	58,0	32,5	50	MS1162	PMT04525	MS2002	1,85	4.08
6000408	KM4X63KGMSL50C	KM4X63	73,5	31,0	50	MS1162	PMT04525	MS2002	1,86	4.11

- Standard PSC Quick-Change platform.
- Through the pocket coolant capable.
- Interchangeable blades for versatility and depth of cut.

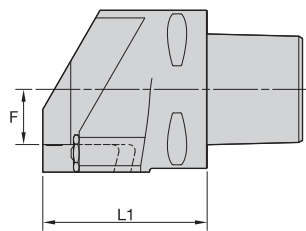
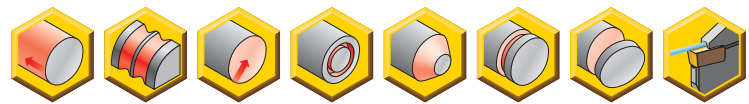

Right Hand

### ■ Modular Straight PSC System with Coolant



order number	catalogue number	CSMS system size	L1	F	blade size	blade screw	Torx	clamp screw	Torx
<b>right hand</b>									
6000028	PSC40KGMSR50C	PSC40	63,5	10,0	50	MS1162	T25	MS2002	T25
5405654	PSC50KGMSR65C	PSC50	49,0	25,5	65	MS1163	T30	—	—
6000152	PSC50KGMSR50C	PSC50	63,5	15,0	50	MS1162	T25	MS2002	T25
6000464	PSC63KGMSR65C	PSC63	60,5	21,0	65	MS1163	T30	—	—
6000211	PSC63KGMSR50C	PSC63	65,5	22,0	50	MS1162	T25	MS2002	T25
6000468	PSC80KGMSR65C	PSC80	68,5	29,0	65	MS1163	T30	—	—
6000216	PSC80KGMSR50C	PSC80	73,5	30,0	50	MS1162	T25	MS2002	T25
<b>left hand</b>									
6000029	PSC40KGMSL50C	PSC40	63,5	10,0	50	MS1162	T25	MS2002	T25
5405655	PSC50KGMSL65C	PSC50	49,0	25,5	65	MS1163	T30	—	—
6000153	PSC50KGMSL50C	PSC50	63,5	15,0	50	MS1162	T25	MS2002	T25
6000465	PSC63KGMSL65C	PSC63	60,5	21,0	65	MS1163	T30	—	—
6000213	PSC63KGMSL50C	PSC63	65,5	22,0	50	MS1162	T25	MS2002	T25
6000469	PSC80KGMSL65C	PSC80	68,5	29,0	65	MS1163	T30	—	—
6000217	PSC80KGMSL50C	PSC80	73,5	30,0	50	MS1162	T25	MS2002	T25

- Standard PSC Quick-Change platform.
- Through the pocket coolant capable.
- Interchangeable blades for versatility and depth of cut.

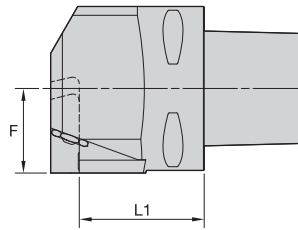
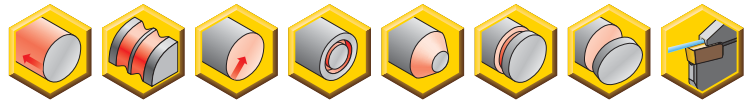

Right Hand

Grooving and Cut-Off

### ■ Modular End Mount PSC System with Coolant



order number	catalogue number	CSMS system size	L1	F	blade size	blade screw	Torx	clamp screw	Torx
<b>right hand</b>									
6000026	PSC40KGMER50C	PSC40	33,0	20,5	50	MS1162	T25	MS2002	T25
6000030	PSC50KGMER50C	PSC50	43,0	25,5	50	MS1162	T25	MS2002	T25
5405652	PSC50KGMER65C	PSC50	55,5	22,0	65	MS1163	T30	—	—
6000159	PSC63KGMER50C	PSC63	48,0	32,5	50	MS1162	T25	MS2002	T25
6000462	PSC63KGMER65C	PSC63	49,0	32,5	65	MS1163	T30	—	—
6000466	PSC80KGMER65C	PSC80	57,0	40,5	65	MS1163	T30	—	—
6000214	PSC80KGMER50C	PSC80	58,0	40,5	50	MS1162	T25	MS2002	T25
<b>left hand</b>									
6000027	PSC40KGMEL50C	PSC40	33,0	20,5	50	MS1162	T25	MS2002	T25
6000151	PSC50KGMEL50C	PSC50	43,0	25,5	50	MS1162	T25	MS2002	T25
5405653	PSC50KGMEL65C	PSC50	55,5	22,0	65	MS1163	T30	—	—
6000160	PSC63KGMEL50C	PSC63	48,0	32,5	50	MS1162	T25	MS2002	T25
6000463	PSC63KGMEL65C	PSC63	49,0	32,5	65	MS1163	T30	—	—
6000467	PSC80KGMEL65C	PSC80	57,0	40,5	65	MS1163	T30	—	—
6000215	PSC80KGMEL50C	PSC80	58,0	40,5	50	MS1162	T25	MS2002	T25



# ➤ Top Notch™

Grooving Tools and Beyond™ Inserts for  
Your Shallow Groove and Turn Operations

## Primary Application

Top Notch Grooving Tools and Beyond Inserts are the proven solution for high productivity. The Top Notch system provides consistent tool performance, accurate indexing, and superior clamping to provide excellent surface finishing and superior tool life.

## Features and Benefits

- The Beyond PVD coated grades are designed to cut a variety of workpiece materials.
- Rigid clamping securely locks insert in place through the toughest cuts.
- Versatile design enables one system to handle O.D. and I.D. grooving, face grooving, back turning, undercutting, and even threading operations.
- Chip control inserts provide excellent chip evacuation in grooving, and offer better chip control in multidirectional turning.

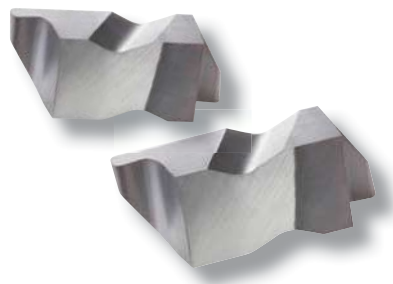

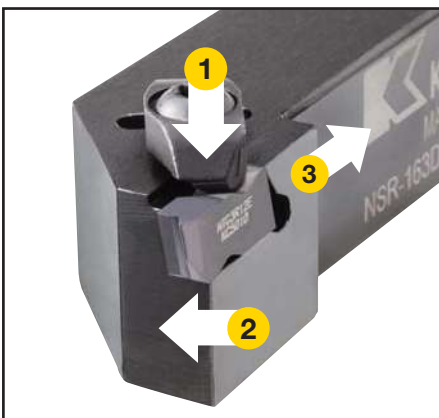

Our rigid clamping design prevents insert movement during high-feed rate applications. This benefit ensures excellent surface finish, improved productivity, and superior tool life and promotes perfect concentricity. The rugged bridge clamp generates locking forces in three directions to provide superior resistance to side thrust and tangential forces.

## Step 1 • Select system based on the required groove depth

### What you need to know

- Groove depth, width, and profile.
- Material to be machined.
- Application to be performed (face, O.D., or I.D. grooving).
- Toolholder requirements (e.g., KM™, square shank, right/left).

### Top Notch™

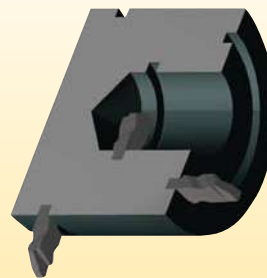

### Grooving

For grooving depth  $\leq 1.5x$  grooving width, review system capability chart and proceed to Step 2.

## Top Notch Grooving for Internal, External, and Face Grooving Applications

system capabilities		minimum in (mm)	maximum in (mm)
O.D./I.D. grooving	width	0.31 (0,79)	.375 (9,53)
	depth	.050 (1,27)	.375 (9,53)
face grooving	width	.125 (3,18)	.375 (9,53)
	depth	.150 (3,81)	.250 (6,35)
internal grooving	diameter	.440 (11,2)	—
face grooving diameter	standard	.940 (23,9)	—
	deep	1.875 (47,6)	—
deep O.D./I.D. grooving	width	.062 (1,57)	.250 (6,35)
	depth	.125 (3,18)	.500 (12,70)
deep face grooving	width	.125 (3,18)	.250 (6,35)
	depth	.250 (6,35)	.500 (12,70)

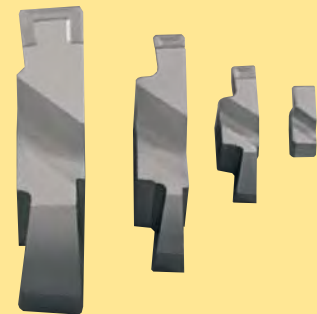

## Step 2 • Select toolholder based on the application

NOTE: Toolholders are available as conventional square shank versions as well as Quick-Change versions. The insert size must match the gage insert of your toolholder selection.

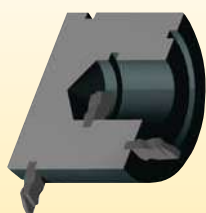
**Step 3 • Select chipbreaker style and feed rate**
**Chipbreaker and Feed Rates • in/rev (mm/rev)**

workpiece material and application	P	M	K	N	S	H
first choice	<b>NG-K</b> .003-.011 (0,08-0,28)	<b>NG-K</b> .0025-.008 (0,07-0,20)	<b>NG</b> .004-.012 (0,01-0,30)	<b>NGP</b> .004-.012 (0,01-0,30)	<b>NG-K</b> .0025-.008 (0,07-0,20)	<b>NG-ST</b> CBN tipped .002-.004 (0,05-0,10)
alternate choice	<b>NG</b> .004-.012 (0,10-0,30)	<b>NGP</b> .004-.009 (0,10-0,23)	<b>NG-K</b> .003-.011 (0,08-0,28)	<b>NG-K</b> .003-.012 (0,08-0,30)	<b>NGP</b> .004-.008 (0,10-0,20)	—

\_K chipbreaker inserts



flat-top inserts

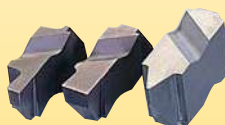

positive rake inserts

**Step 4 • Select grade and speed**
**Recommendations for Grade**

Starting speed chart shown under "Application Guide"

machining condition	workpiece material					
	P	M	K	N	S	H
<b>high-performance for optimal conditions</b> (clean cuts, good machine condition, higher speed capability)	<b>KCP10B</b> 120-450	<b>KCU10</b> 120-260	<b>KCK20B</b> 150-550	<b>KD1425</b> 150-1500	<b>KCU10</b> 15-170	<b>KB5625</b> 45-230
<b>general purpose</b> (first choice for general machining)	<b>KCP25B</b> 110-365	<b>KCU25</b> 120-245	<b>KCU10</b> 60-245	<b>KCU10</b> 120-975	<b>KCU10</b> 15-135	<b>KB5625</b> 80-150
<b>unfavourable conditions</b> (roughing, poor machine condition, interrupted cuts, low speed, I.D. grooving)	<b>KCU25</b> 85-270	<b>KCU25</b> 90-210	<b>KCU25</b> 50-195	<b>K313</b> 40-610	<b>KCU25</b> 8-110	<b>KB1630</b> 45-120

**Step 5 • Select insert and holder from catalogue page**

NOTE: The insert size must match the gage insert size of your toolholder selection.

**Example for Top Notch • Grooving**

Material ..... low-alloyed steel  
 Groove depth ..... 2mm (.079")  
 Groove width ..... 3mm (.118")  
 Operation ..... I.D. cut, limited speed capability,  
 plunge groove and chamfer

**Recommendation**

Insert ..... NG2M300RK  
 Grade ..... KC5025  
 Insert width ..... 3mm (.118")  
 Insert size ..... 2

Toolholder ..... A20QNTOL2 (metric)  
 A12NEL2 (inch)  
 Gage insert ..... N.2R

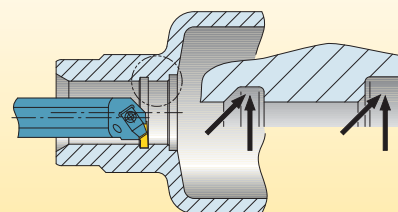

Speed: 120 m/min (400 SFM)  
 Feed: 0,15 mm/rev (.006 in/rev)

**Congratulations!**

You have successfully maximised your productivity by selecting the best Top Notch insert geometry, grade, and cutting specifications for your application!

## How Do Catalogue Numbers Work?

Each character in our catalogue number signifies a specific trait of that product. Use the following key columns and corresponding images to easily identify which attributes apply.

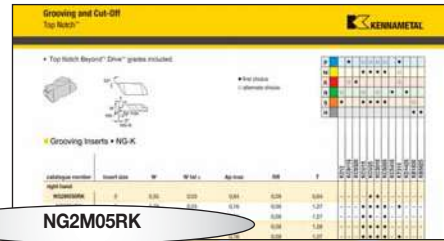

N	G		2	M	05	R		K														
Type of Insert	Insert Style	Additional Information	Insert Size	Size Identification	Groove Size**	Hand of Insert	Cutting Depth	Chipbreaker Design	Definition of Inserts													
<p><b>N</b> = Top Notch</p>		<p><b>D</b> = Deep grooving <b>P</b> = Positive <b>C</b> = Groove and chamfer</p>		<p><b>M</b> = Metric insert groove width <b>C</b> = Circlip groove insert width is nominal circlip size □ = Blank indicates inch width insert</p>		<p><b>L</b> = Left hand <b>R</b> = Right hand</p>	<p>Shown for groove and chamfer inserts in 0,01mm increments.</p>	<p><b>E</b> = Hone only <b>K</b> = Standard chip control <b>S</b> = T Land and Hone <b>ST</b> = STD Tip (PcBN)</p>	<p>Groove size "J" or "L" for Poly-Vee inserts "I" indicates internal face grooving</p>													
	<p><b>B</b> = Blank (for special forms) <b>F</b> = Face grooving <b>G</b> = Grooving <b>P</b> = Back <b>R</b> = Full radius <b>U</b> = Undercutting (or relieving) <b>V</b> = Poly-Vee</p>		<table border="1"> <thead> <tr> <th>insert number</th> <th>W1 mm</th> </tr> </thead> <tbody> <tr><td>1</td><td>2,54</td></tr> <tr><td>2</td><td>3,81</td></tr> <tr><td>3</td><td>4,95</td></tr> <tr><td>4</td><td>6,98</td></tr> <tr><td>5</td><td>9,65</td></tr> <tr><td>6</td><td>9,73</td></tr> </tbody> </table>	insert number	W1 mm	1	2,54	2	3,81	3	4,95	4	6,98	5	9,65	6	9,73		<p>Position pertains to groove width for F-, G-, and U-style inserts, radii for R-style grooving inserts, and circlip size for groove and chamfer inserts. Dimension in 0,01mm.</p> <p><b>Metric example:</b> 3,25mm width groove or radius equals "325" catalogue position number.</p> <p><b>Width Tolerance:</b> ±0,025mm unless otherwise specified.</p>			
insert number	W1 mm																					
1	2,54																					
2	3,81																					
3	4,95																					
4	6,98																					
5	9,65																					
6	9,73																					

\*Kennametal proprietary identification system.  
\*\*Omit position for Top Notch NB-style blanks.

### Top Notch Threading and Grooving Insert Dimensions

insert size	S mm	W1 mm
1	2,54	2,54
2	5,56	3,81
3	8,74	4,95
4	11,51	6,48
5	17,48	9,65
6	11,51	9,73
8	7,93	11,13

### Top Notch Holder Design

NOTE: Holders are designed to locate insert inclined to 3° to provide back clearance down open side.

**Kennametal and Top Notch tooling technology combine to bring you the very best threading and grooving system available in the world today.**

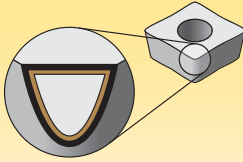





Coatings provide high-speed capability and are engineered for finishing to light roughing.

P	Steel
M	Stainless Steel
K	Cast Iron
N	Non-Ferrous
S	High-Temp Alloys
H	Hardened Materials

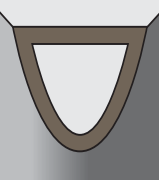
wear resistance ← → toughness

Grades

Coating	Grade Description		05	10	15	20	25	30	35	40	45
KCU10	 <b>Composition:</b> An advanced multilayer PVD coating over a very deformation-resistant unalloyed carbide substrate. The new and improved coating improves edge stability with wide range speed and feed capabilities. <b>Application:</b> The KCU10™ grade is ideal for finishing to general machining of most workpiece materials at a wide range of speed and feed capabilities. Excellent for machining most steels, stainless steels, cast irons, non-ferrous materials, and high-temp alloys with improved edge toughness, notch resistance, and higher cutting speed/feed capability.	P									
		M									
		K									
		N									
		S									
		H									
KCU25	 <b>Composition:</b> An advanced PVD grade with hard AlTiN coating and fine-grain unalloyed substrate. The new and improved coating improves edge stability with wide range speed and feed capabilities. <b>Application:</b> The KCU25™ grade is ideal for general machining of most steels, stainless steels, high-temp alloys, titanium, irons, and non-ferrous materials in a wide range of speeds and feeds with improved edge toughness for interrupted cut and high feed rates.	P									
		M									
		K									
		N									
		S									
KCP10B	 <b>Composition:</b> A specially engineered cobalt-enriched carbide grade with thick MTCVD TiCN-Al <sub>2</sub> O <sub>3</sub> -TiOCN coating for maximum wear resistance. <b>Application:</b> An excellent finishing to medium machining grade for a variety of workpiece materials, including most steels, ferritic, martensitic, and PH stainless steels, and cast irons. The cobalt-enriched substrate offers a balanced combination of deformation resistance and edge toughness, while the thick coating layers offer outstanding abrasion resistance and crater wear resistance for high-speed machining. Smooth coating provides resistance to edge build-up and microchipping and produces excellent surface finishes.	P									
		M									
		K									
		N									
		S									
		H									
KCP25B	 <b>Composition:</b> A tough cobalt-enriched carbide grade with a multilayer MTCVD TiCN-Al <sub>2</sub> O <sub>3</sub> -TiOCN coating with superior interlayer adhesion. <b>Application:</b> Best general-purpose turning grade for most steels and ferritic and martensitic stainless steels. The substrate design ensures adequate deformation resistance with excellent insert edge strength. Coating layers offer good wear resistance over a wide range of machining conditions and the post-coat treatment minimises microchipping and improves coating adhesion to substrate leading to long tool life and improved workpiece finishes.	P									
		M									
		K									
		N									
		S									
		H									
KCK20B	 <b>Composition:</b> A specially toughened MTCVD TiCN-Al <sub>2</sub> O <sub>3</sub> -TiOCN coating over a wear-resistant substrate. <b>Application:</b> Specifically engineered to maximise coating adhesion and edge strength making this grade ideal in wet interrupted cutting of grey and ductile irons. It can be used in a wide range of applications from finishing to roughing to maximise productivity wherever strength and reliability are needed.	P									
		M									
		K									
		N									
		S									
		H									

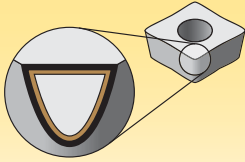

Coatings provide high-speed capability and are engineered for finishing to light roughing.

P	Steel
M	Stainless Steel
K	Cast Iron
N	Non-Ferrous
S	High-Temp Alloys
H	Hardened Materials

wear resistance ← → toughness

Grades

Coating	Grade Description		05	10	15	20	25	30	35	40	45	
K313	<p><b>Composition:</b> A hard, low binder content, unalloyed WC/Co fine-grain grade.</p> <p><b>Application:</b> Exceptional edge wear resistance combined with very high strength for machining titanium, cast irons, austenitic stainless steels, non-ferrous metals, non-metals, and most high-temp alloys. Superior thermal deformation and depth-of-cut notch resistance. The grain structure is well controlled for minimal pits and flaws, which contributes to long, reliable service.</p>											
		M										
		K										
		N										
		S										
KC5010	<p><b>Composition:</b> An advanced PVD AlTiN coating over a very deformation-resistant unalloyed carbide substrate.</p> <p><b>Application:</b> The KC5010™ grade is ideal for finishing to general machining of most workpiece materials at higher speeds. Excellent for machining most steels, stainless steels, cast irons, non-ferrous materials, and high-temp alloys under stable conditions. It also performs well machining hardened and short chipping materials.</p>	P										
		M										
		K										
		N										
		S										
		H										
KC5025	<p><b>Composition:</b> An advanced PVD-AlTiN-coated grade with a tough, ultra-fine-grain unalloyed substrate.</p> <p><b>Application:</b> For general-purpose machining of most steels, stainless steels, high-temp alloys, titanium, irons, and non-ferrous materials. Speeds may vary from low to medium and will handle interruptions and high feed rates.</p>	P										
		M										
		K										
		N										
		S										

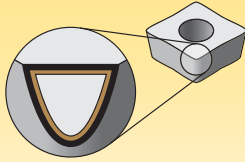

Coatings provide high-speed capability and are engineered for finishing to light roughing.















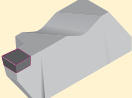



P	Steel
M	Stainless Steel
K	Cast Iron
N	Non-Ferrous
S	High-Temp Alloys
H	Hardened Materials

wear resistance ← → toughness

Grades

Coating	Grade Description		05	10	15	20	25	30	35	40	45	
KT315	<p><b>Composition:</b> A multilayer PVD TiN/TiCN/TiN-coated cermet turning grade.</p> <p><b>Application:</b> Ideal for high-speed finishing to medium machining of most carbon and alloy steels and stainless steels. Performs very well in cast and ductile iron applications, too. Provides long and consistent tool life and will produce excellent workpiece finishes.</p>	P										
		K										
KB1630	<p><b>Composition:</b> An uncoated high content PcBN grade. PcBN tips are brazed onto a carbide insert.</p> <p><b>Application:</b> Designed for roughing to finishing in interrupted cuts on hardened steels (&gt;45 HRC). It can also be applied on grey cast iron, chilled irons, high chrome alloyed steels, high temp alloys and sintered powder metals. The tipped PcBN inserts are available in a wide range of insert styles, including Top Notch™ and Screw-On geometries.</p>	K										
		S										
		H										
KB5625	<p><b>Composition:</b> A medium content PcBN with a PVD-TiN/AlTiN coating for added wear resistance.</p> <p><b>Application:</b> Designed for roughing to finishing of hardened steels (&gt;45 HRC). Use on bearing steels, hot and cold work steels, die steels, case hardened steels, carburised and nitrided irons, and some hard coatings.</p>	H										
KD1425	<p><b>Composition:</b> A multimodal PCD grade with a range of grain sizes brazed onto a carbide substrate.</p> <p><b>Application:</b> Engineered for extreme abrasion resistance, combined with good edge strength for demanding applications. An ideal choice for high-silicon aluminium alloys, bi-metallic (AL/GC) materials, MMC, carbon-fibre reinforced plastics, and other abrasive non-metallic materials.</p>	N										



insert style	application	rake angle	page(s)	insert style	application	rake angle	page(s)
<b>NG</b> 	<ul style="list-style-type: none"> <li>• General-purpose grooving.</li> <li>• O-ring grooving.</li> <li>• Circlip grooving.</li> </ul>	neutral	C154	<b>NFD-KI</b> 	<ul style="list-style-type: none"> <li>• Internal deep face grooving with chip control.</li> <li>• For use in boring bars for internal face grooves.</li> </ul>	10° positive	C160
<b>NG-K</b> 	<ul style="list-style-type: none"> <li>• Chip control geometry.</li> <li>• General-purpose grooving.</li> <li>• O-ring grooving.</li> <li>• Circlip grooving.</li> <li>• Light turning.</li> </ul>	10° positive	C146	<b>NP-K NPD-K</b> 	<ul style="list-style-type: none"> <li>• Turning.</li> <li>• Back turning positive.</li> <li>• Profiling with chip control.</li> </ul>	10° positive	C151
<b>NG-ST</b> 	<ul style="list-style-type: none"> <li>• Hard turning.</li> </ul>	neutral	C163	<b>NR</b> 	<ul style="list-style-type: none"> <li>• Full radius grooving.</li> <li>• Turning and profiling.</li> </ul>	neutral	C158
<b>NGC-K</b> 	<ul style="list-style-type: none"> <li>• Combined groove and chamfered edge break in one positive plunge with chip control.</li> <li>• Designed for DIN 471/472 standard circlip grooves.</li> </ul>	10° positive	C152	<b>NR-K</b> 	<ul style="list-style-type: none"> <li>• Chip control geometry.</li> <li>• Full radius grooving, turning, and profiling.</li> </ul>	10° positive	C150
<b>NGD</b> 	<ul style="list-style-type: none"> <li>• Deep grooving.</li> </ul>	neutral	C157	<b>NRD</b> 	<ul style="list-style-type: none"> <li>• Deep grooving.</li> <li>• Full radius end-form.</li> </ul>	neutral	C159
<b>NGD-K</b> 	<ul style="list-style-type: none"> <li>• Chip control geometry.</li> <li>• Deep grooving.</li> <li>• Light turning.</li> </ul>	10° positive	C149	<b>NRP</b> 	<ul style="list-style-type: none"> <li>• Full radius grooving.</li> <li>• Light-turning profiling.</li> </ul>	5° positive	C153
<b>NGP</b> 	<ul style="list-style-type: none"> <li>• General-purpose grooving.</li> <li>• O-ring grooving.</li> <li>• Circlip grooving.</li> </ul>	5° positive	C152	<b>NU</b> 	<ul style="list-style-type: none"> <li>• Undercutting.</li> </ul>	neutral	C161
<b>NF</b> 	<ul style="list-style-type: none"> <li>• Face grooving.</li> <li>• Additional side clearance.</li> </ul>	neutral	C161	<b>NV</b> 	<ul style="list-style-type: none"> <li>• Poly-Vee grooving.</li> </ul>	neutral	C162
<b>NF-K</b> 	<ul style="list-style-type: none"> <li>• Face grooving with chip control.</li> <li>• Additional side clearance.</li> </ul>	10° positive	C159	<b>NB/NBD</b> 	<ul style="list-style-type: none"> <li>• Blanks.</li> <li>• Blanks for deep grooving.</li> <li>• Available in uncoated grades only.</li> </ul>	—	C162–C163
<b>NFD-K</b> 	<ul style="list-style-type: none"> <li>• Deep face grooving with chip control.</li> <li>• Additional side clearance.</li> </ul>	10° positive	C160				

# Kennametal on the Web

kennametal.com

## FIND THE LATEST PRODUCT INFORMATION

Whether your operation is turning, milling, or holemaking, Kennametal brands are the high-performance tooling you need. We offer standard and custom solutions for a wide range of applications.

Find information about our most current campaigns and catalogues.

Register on Konnect for the full functionality of the Kennametal online ordering website.

## CONTACT US

Our customers are important to us. We want to provide you the best customer service in the industry. If you have a comment or question, please send it to us. We strive to respond to all inquiries within 24 hours.

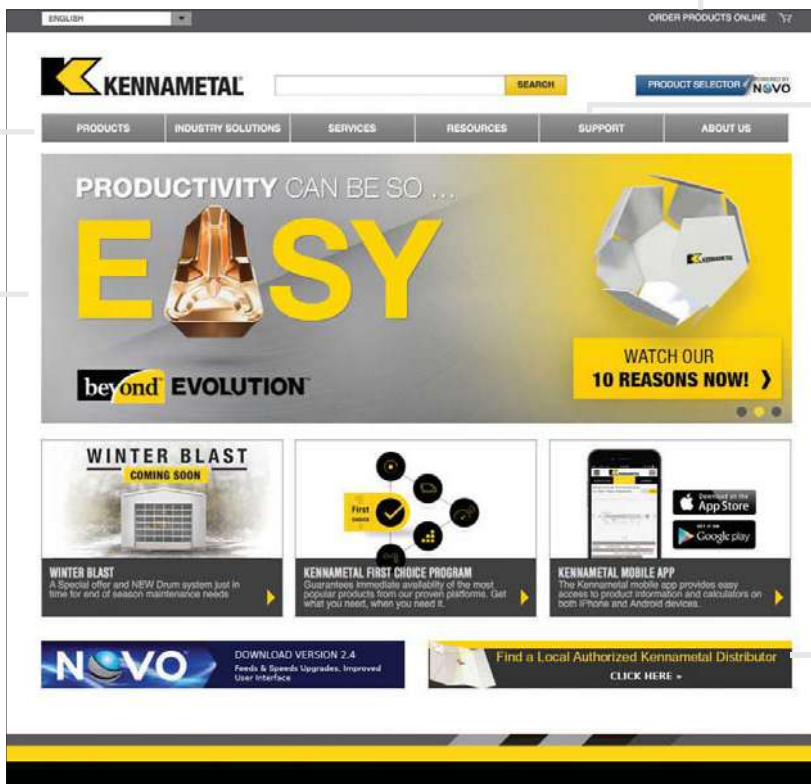

## FIND A LOCAL AUTHORISED DISTRIBUTOR IN YOUR AREA

Kennametal offers world-class products and services globally. Our distributors know us, and more importantly, they know you. They know better than anyone in the industry how to put the global power of Kennametal to work for you — in your industry, in your region, and for your business.









- Full radius inserts with chip control.

Grooving and Cut-Off

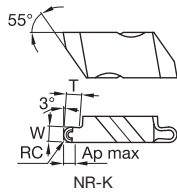
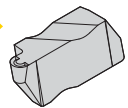

- first choice
- alternate choice

	P	M	K	N	S	H	KCU10	KCU25	KCP10B	KCP25B	KCK20B	K313	KC5010	KC5025	KT315	KB1630	KB5625	KD1425
right hand	●	●	○	○	○	○	●	●	-	-	-	-	●	●	-	-	-	-
NR3031RK	●	●	○	○	○	○	●	●	-	-	-	-	●	●	-	-	-	-
NR3047RK	●	●	○	○	○	○	●	●	-	-	-	-	●	●	-	-	-	-
NR3062RK	●	●	○	○	○	○	●	●	-	-	-	-	●	●	-	-	-	-
NR3078RK	●	●	○	○	○	○	●	●	-	-	-	-	●	●	-	-	-	-
NR4062RK	●	●	○	○	○	○	●	●	-	-	-	-	●	●	-	-	-	-
NR4094RK	●	●	○	○	○	○	●	●	-	-	-	-	●	●	-	-	-	-
NR4125RK	●	●	○	○	○	○	●	●	-	-	-	-	●	●	-	-	-	-
left hand	○	○	○	○	○	○	○	○	○	○	○	○	○	○	○	○	○	○
NR3031LK	○	○	○	○	○	○	○	○	○	○	○	○	○	○	○	○	○	○
NR3047LK	○	○	○	○	○	○	○	○	○	○	○	○	○	○	○	○	○	○
NR3062LK	○	○	○	○	○	○	○	○	○	○	○	○	○	○	○	○	○	○
NR3078LK	○	○	○	○	○	○	○	○	○	○	○	○	○	○	○	○	○	○
NR4062LK	○	○	○	○	○	○	○	○	○	○	○	○	○	○	○	○	○	○
NR4094LK	○	○	○	○	○	○	○	○	○	○	○	○	○	○	○	○	○	○
NR4125LK	○	○	○	○	○	○	○	○	○	○	○	○	○	○	○	○	○	○

NOTE: Right-hand insert shown; left-hand insert is mirror image.

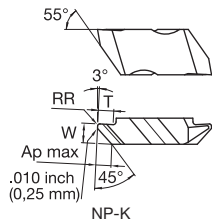
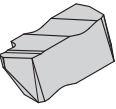

● first choice  
○ alternate choice

P	●	●	●	○	○	○	○	○	○	○	○	○	○	○	○	○	○	○	○	○
M	●	●	○	○	○	○	○	○	○	○	○	○	○	○	○	○	○	○	○	○
K	○	○	○	○	○	○	○	○	○	○	○	○	○	○	○	○	○	○	○	○
N	●	○	○	○	○	○	○	○	○	○	○	○	○	○	○	○	○	○	○	○
S	●	●	○	○	○	○	○	○	○	○	○	○	○	○	○	○	○	○	○	○
H	○	○	○	○	○	○	○	○	○	○	○	○	○	○	○	○	○	○	○	○

**Groove and Profile • Chip Control**

catalogue number	insert size	W	W tol ±	Ap max	RR	T	KCU10	KCU25	KCP10B	KCP25B	KCK20B	K313	KC5010	KC5025	KT315	KB1630	KB5625	KD1425	
<b>right hand</b>																			
NP2002RK	2	3,82	0,03	—	0,25	2,81	●	●	—	—	—	—	●	●	—	—	—	—	—
NP2012RK	2	3,82	0,03	—	0,25	2,81	—	●	—	—	—	—	—	—	—	—	—	—	—
NP3002RK	3	4,95	0,03	—	0,25	5,08	●	●	—	—	—	—	●	—	—	—	—	—	—
NP3012RK	3	4,95	0,03	—	0,25	5,08	—	●	—	—	—	—	●	—	—	—	—	—	—

NOTE: Right-hand insert shown; left-hand insert is mirror image.  
Tolerance on W ± 0,13mm (± .005").

- Profiling deep positive inserts.

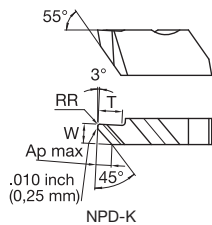
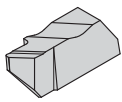

**Groove and Profile • Deep Grooving • Chip Control**

catalogue number	insert size	W	W tol ±	Ap max	RR	T	KCU10	KCU25	KCP10B	KCP25B	KCK20B	K313	KC5010	KC5025	KT315	KB1630	KB5625	KD1425	
<b>right hand</b>																			
NPD2002RK	2	3,68	0,13	—	0,09	5,08	—	●	—	—	—	—	●	—	—	—	—	—	—
NPD3002RK	3	4,83	0,13	—	0,09	6,35	—	●	—	—	—	—	—	—	—	—	—	—	—
NPD3012RK	3	4,95	0,03	—	0,25	6,35	●	●	—	—	—	—	●	—	—	—	—	—	—

NOTE: Right-hand insert shown; left-hand insert is mirror image.  
Tolerance on W ± 0,13mm (± .005").





- Full radius positive rake inserts.

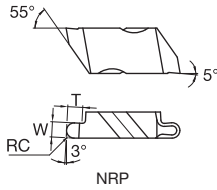
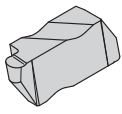

- first choice
- alternate choice

	P	M	K	N	S	H	KCU10	KCU25	KCP10B	KCP25B	KCK20B	K313	KC5010	KC5025	KT315	KB1630	KB5625	KD1425	
P	●	●	●	○	○	○	○	○	○	○	○	○	○	○	○	○	○	○	○
M	●	●	○	○	○	○	○	○	○	○	○	○	○	○	○	○	○	○	○
K	○	○	○	○	○	○	○	○	○	○	○	○	○	○	○	○	○	○	○
N	●	○	○	○	○	○	○	○	○	○	○	○	○	○	○	○	○	○	○
S	●	●	○	○	○	○	○	○	○	○	○	○	○	○	○	○	○	○	○
H	○	○	○	○	○	○	○	○	○	○	○	○	○	○	○	○	○	○	○

### ■ Groove and Turn • Full Radius • Positive

catalogue number	insert size	W	Ap max	RC	T	KCU10	KCU25	KCP10B	KCP25B	KCK20B	K313	KC5010	KC5025	KT315	KB1630	KB5625	KD1425	
<b>right hand</b>																		
NRP3031R	3	1,58	—	0,79	2,39	●	—	—	—	—	—	●	—	—	—	—	—	—
NRP3047R	3	2,39	—	1,19	3,81	●	—	—	—	—	—	●	—	—	—	—	—	—
NRP3062R	3	3,18	—	1,59	3,81	●	—	—	—	—	—	●	—	—	—	—	—	—
NRP3094R	3	4,78	—	2,39	3,81	●	—	—	—	—	—	●	—	—	—	—	—	—
<b>left hand</b>																		
NRP3031L	3	1,58	—	0,79	2,39	●	—	—	—	—	—	●	—	—	—	—	—	—
NRP3047L	3	2,39	—	1,19	3,81	●	—	—	—	—	—	●	—	—	—	—	—	—
NRP3062L	3	3,18	—	1,59	3,81	—	—	—	—	—	—	●	—	—	—	—	—	—
NRP3094L	3	4,78	—	2,39	3,81	●	—	—	—	—	—	●	—	—	—	—	—	—

NOTE: Right-hand insert shown; left-hand insert is mirror image.







# Mobile App

The Kennametal mobile app makes it easy to access product information, calculators, and much more from iPhone® and Android™ devices.

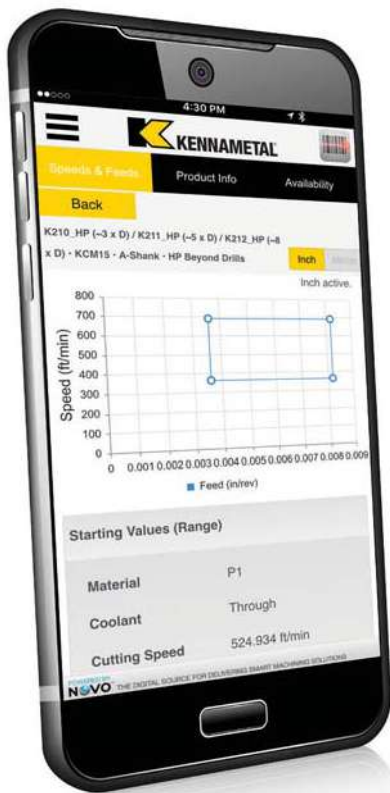

## FEATURES

Scan a Kennametal tool package barcode or search a product catalogue number to access complete product information.

Product information includes tool image, dimensions, grades, and product highlights.

View product availability at global locations.

Get speed and feed information in inch and metric values for all metalcutting products.

View tech tips for helpful solutions to common machining questions.

Contact Customer Support directly from the app.

## MACHINING CALCULATORS

View data for milling and drilling applications.

Inch and metric values calculated.

## ORDERING

Login using your Konnect credentials to complete a purchase.

## WHERE TO FIND IT

Download the free app today from iTunes® or the Google Play™ store.



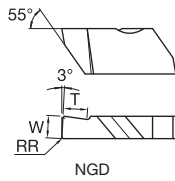
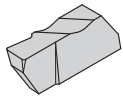

● first choice  
○ alternate choice

	P	M	K	N	S	H	KCU10	KCU25	KCP10B	KCP25B	KCK20B	K313	KC5010	KC5025	KT315	KB1630	KB5625	KD1425	
P	●	●	●	○	○	○	○	○	○	○	○	○	○	○	○	○	○	○	○
M	●	●	○	○	○	○	○	○	○	○	○	○	○	○	○	○	○	○	○
K	○	○	○	○	○	○	○	○	○	○	○	○	○	○	○	○	○	○	○
N	●	○	○	○	○	○	○	○	○	○	○	○	○	○	○	○	○	○	○
S	●	●	○	○	○	○	○	○	○	○	○	○	○	○	○	○	○	○	○
H	○	○	○	○	○	○	○	○	○	○	○	○	○	○	○	○	○	○	○



■ Groove and Turn • Deep Grooving • Flat Top

catalogue number	insert size	W	W tol ±	Ap max	RR	T	KCU10	KCU25	KCP10B	KCP25B	KCK20B	K313	KC5010	KC5025	KT315	KB1630	KB5625	KD1425
<b>right hand</b>																		
NGD3189R	3	4,80	0,03	—	0,57	6,35	●	-	-	-	-	●	-	-	-	-	-	-
NGD4250R	4	6,35	0,03	—	0,57	12,70	●	-	-	-	-	●	-	-	-	-	-	-
<b>left hand</b>																		
NGD3189L	3	4,80	0,03	—	0,57	6,35	●	-	-	-	-	●	●	-	-	-	-	-
NGD4250L	4	6,35	0,03	—	0,57	12,70	●	-	-	-	-	●	●	-	-	-	-	-

NOTE: Inserts have one cutting edge.  
Right-hand insert shown; left-hand insert is mirror image.

















## How Do Catalogue Numbers Work?

Each character in our catalogue number signifies a specific trait of that product. Use the following key columns and corresponding images to easily identify which attributes apply.

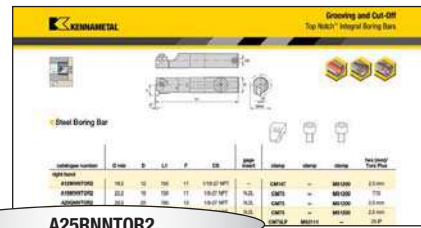

**A25RNNTOR2**

<b>A</b>	<b>25</b>	<b>R</b>	<b>N</b>	<b>N</b>	<b>T</b>	<b>0</b>	<b>R</b>	<b>2</b>																
Bar Type	Bar Diameter	Bar Length	Insert Holding Method	Insert Shape	Insert Location	Rake Angle	Hand of Bar	Insert Size																
 A = Steel with coolant	 Bar diameter in millimetres	 N* = Top Notch	 E = End mount	 S = Straight mount	 R = Right hand	 L = Left hand	 R = Right hand	 L = Left hand																
 H = Interchangeable head	metric bars: K = 125mm M = 150mm Q = 180mm R = 200mm S = 250mm T = 300mm U = 350mm	 A = Steel with coolant		 E = End mount		 S = Straight mount		 A = Steel with coolant																
						 A = Steel with coolant																		
						<table border="1" style="margin-left: auto; margin-right: auto;"> <thead> <tr> <th style="text-align: center;">insert size</th> <th style="text-align: center;">T mm</th> </tr> </thead> <tbody> <tr><td style="text-align: center;">1</td><td style="text-align: center;">3,54</td></tr> <tr><td style="text-align: center;">2</td><td style="text-align: center;">3,81</td></tr> <tr><td style="text-align: center;">3</td><td style="text-align: center;">5,35</td></tr> <tr><td style="text-align: center;">4</td><td style="text-align: center;">6,40</td></tr> <tr><td style="text-align: center;">5</td><td style="text-align: center;">9,65</td></tr> <tr><td style="text-align: center;">6</td><td style="text-align: center;">9,73</td></tr> <tr><td style="text-align: center;">8</td><td style="text-align: center;">11,13</td></tr> </tbody> </table>			insert size	T mm	1	3,54	2	3,81	3	5,35	4	6,40	5	9,65	6	9,73	8	11,13
insert size	T mm																							
1	3,54																							
2	3,81																							
3	5,35																							
4	6,40																							
5	9,65																							
6	9,73																							
8	11,13																							

\*Kennametal standard only.

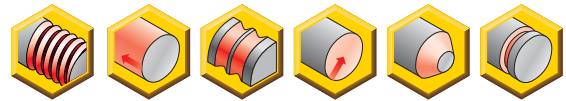
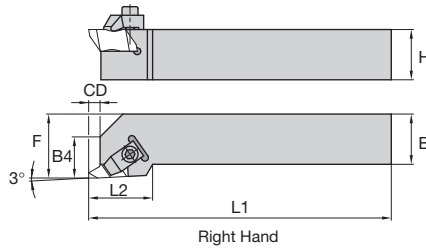
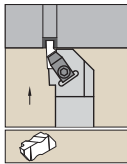

Grooving and Cut-Off

### Integral Straight

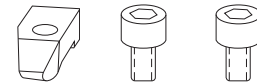

order number	catalogue number	H	B	F	L1	LH	B4	CD	gage insert	clamp	clamp screw	clamp screw	hex (mm)/ Torx Plus
<b>right hand</b>													
1098790	NSR1010E2	10	10	14	70	19	9	3,5	N.2R	CM74	MS1200	—	T10
1098791	NSR1212F2	12	12	16	80	19	9	3,5	N.2R	CM74	MS1200	—	T10
1098792	NSR1616H2	16	16	20	100	19	9	3,5	N.2R	CM74	MS1200	—	T10
1098793	NSR2020K2	20	20	25	125	19	9	3,5	N.2R	CM74	MS1200	—	T10
1098794	NSR2525M2	25	25	32	150	19	9	3,5	N.2R	CM74	MS1200	—	T10
1098795	NSR2020K3	20	20	25	125	32	13	5,3	N.3R	CM72LP	—	MS2111	25 IP
1098796	NSR2525M3	25	25	32	150	32	13	5,3	N.3R	CM72LP	—	MS2111	25 IP
1098797	NSR3225P3	32	25	32	170	32	13	5,3	N.3R	CM72LP	—	MS2111	25 IP
1098798	NSR3232P3	32	32	40	170	32	13	5,3	N.3R	CM72LP	—	MS2111	25 IP
1098799	NSR2525M4	25	25	32	150	35	14	7,5	N.4R	CM72LP	—	MS2111	25 IP
1098800	NSR3225P4	32	25	32	170	35	14	7,5	N.4R	CM72LP	—	MS2111	25 IP
1098801	NSR3232P4	32	32	40	170	35	14	7,5	N.4R	CM72LP	—	MS2111	25 IP
<b>left hand</b>													
1098861	NSL1010E2	10	10	14	70	19	9	3,5	N.2L	CM75	MS1200	—	T10
1098862	NSL1212F2	12	12	16	80	19	9	3,5	N.2L	CM75	MS1200	—	T10
1098863	NSL1616H2	16	16	20	100	19	9	3,5	N.2L	CM75	MS1200	—	T10
1098864	NSL2020K2	20	20	25	125	19	9	3,5	N.2L	CM75	MS1200	—	T10
1098865	NSL2525M2	25	25	32	150	19	9	3,5	N.2L	CM75	MS1200	—	T10
1098866	NSL2020K3	20	20	25	125	32	13	5,3	N.3L	CM73LP	—	MS2111	25 IP
1098867	NSL2525M3	25	25	32	150	32	13	5,3	N.3L	CM73LP	—	MS2111	25 IP
1098868	NSL3225P3	32	25	32	170	32	13	5,3	N.3L	CM73LP	—	MS2111	25 IP
1098869	NSL3232P3	32	32	40	170	32	13	5,3	N.3L	CM73LP	—	MS2111	25 IP
1098870	NSL2525M4	25	25	32	150	35	14	7,5	N.4L	CM73LP	—	MS2111	25 IP
1098871	NSL3225P4	32	25	32	170	35	14	7,5	N.4L	CM73LP	—	MS2111	25 IP
1098872	NSL3232P4	32	32	40	170	35	14	7,5	N.4L	CM73LP	—	MS2111	25 IP

NOTE: F dimension measured over sharp point of N-style threading insert.

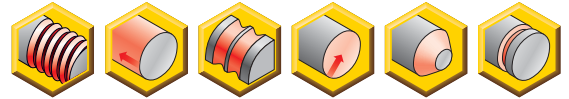
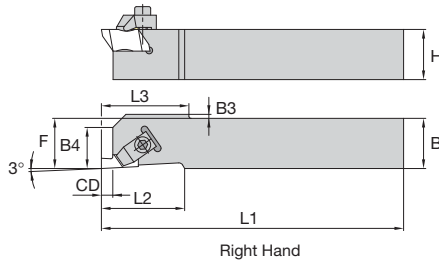
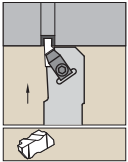

■ Integral Straight • No Offset

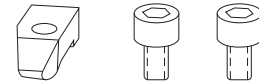

order number	catalogue number	H	B	F	L1	LH	B4	CD	B3	L3	gage insert	clamp	clamp screw	clamp screw	hex (mm)/ Torx Plus
<b>right hand</b>															
1098788	NASR1010M2Q	10	10	10	150	19	9	3,5	2,03	19	N.2R	CM182	MS1200	—	T10
1098789	NASR1212M2Q	12	12	12	150	19	9	3,5	—	—	N.2R	CM182	MS1200	—	T10
1098786	NASR1616K3Q	16	16	16	125	32	13	5,3	—	—	N.3R	CM184LP	—	MS2111	25 IP
<b>left hand</b>															
1098859	NASL1010M2Q	10	10	10	150	19	9	3,5	2,03	19	N.2L	CM183	MS1200	—	T10
1098860	NASL1212M2Q	12	12	12	150	19	9	6,9	—	—	N.2L	CM183	MS1200	—	T10
1098857	NASL1616K3Q	16	16	16	125	32	13	5,3	—	—	N.3L	CM185LP	—	MS2111	25 IP

NOTE: F dimension measured over sharp point of N-style threading insert.

Grooving and Cut-Off



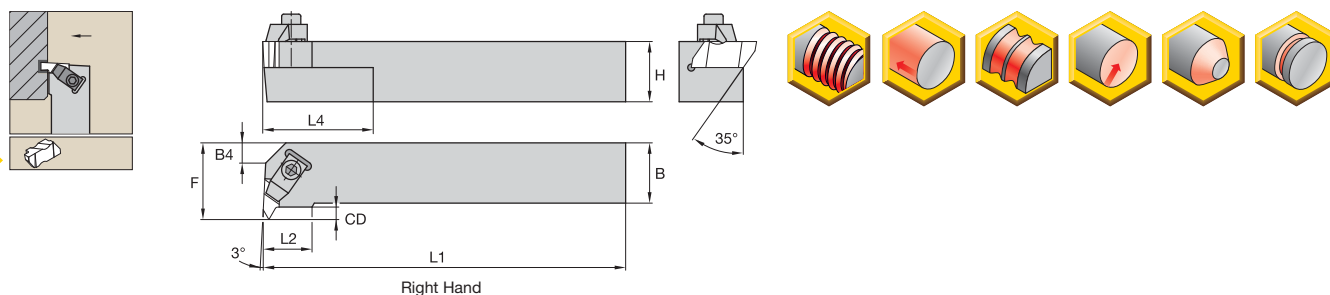

**Integral End Mount**

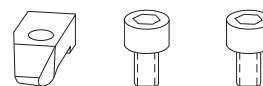

order number	catalogue number	H	B	F	L1	LH	CD	gage insert	clamp	clamp screw	clamp screw	Torx/ Torx Plus
<b>right hand</b>												
1098803	NER1616H2	16	16	20	100	15	3,5	N.2L	CM75	MS1200	—	T10
1098804	NER2020K2	20	20	25	125	15	3,5	N.2L	CM75	MS1200	—	T10
1098805	NER2525M2	25	25	32	150	15	3,5	N.2L	CM75	MS1200	—	T10
1098806	NER2525M3	25	25	32	150	22	5,3	N.3L	CM73LP	—	MS2111	25 IP
1098807	NER3225P3	32	25	32	170	22	3,8	N.3L	CM73LP	—	MS2111	25 IP
1098808	NER2525M4	25	25	35	150	24	6,4	N.4L	CM73LP	—	MS2111	25 IP
1098809	NER3225P4	32	25	35	170	24	6,4	N.4L	CM73LP	—	MS2111	25 IP
1098810	NER3232P4	32	32	40	170	24	6,4	N.4L	CM73LP	—	MS2111	25 IP
<b>left hand</b>												
1098874	NEL1616H2	16	16	20	100	15	3,5	N.2R	CM74	MS1200	—	T10
1098875	NEL2020K2	20	20	25	125	15	3,5	N.2R	CM74	MS1200	—	T10
1098876	NEL2525M2	25	25	32	150	15	3,5	N.2R	CM74	MS1200	—	T10
1098877	NEL2525M3	25	25	32	150	22	5,3	N.3R	CM72LP	—	MS2111	25 IP
1098878	NEL3225P3	32	25	32	170	22	3,8	N.3R	CM72LP	—	MS2111	25 IP
1098879	NEL2525M4	25	25	35	150	24	6,4	N.4R	CM72LP	—	MS2111	25 IP
1098880	NEL3225P4	32	25	35	170	24	6,4	N.4R	CM72LP	—	MS2111	25 IP
1098881	NEL3232P4	32	32	40	170	24	6,4	N.4R	CM72LP	—	MS2111	25 IP

NOTE: F dimension measured over sharp point of N-style threading insert.

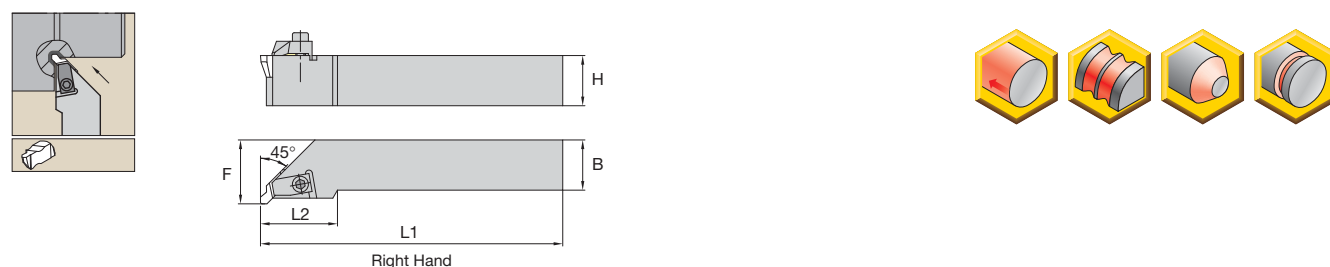

**Integral 45° Undercut • Metric**

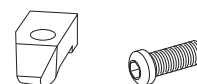

order number	catalogue number	H	B	F	L1	LH	gage insert	clamp	clamp screw	hex (mm)/ Torx Plus
<b>right hand</b>										
1098812	NRR2020K3	20	20	25	125	32	NU3125L	CM73LP	MS2111	25 IP
1098813	NRR2525M3	25	25	32	150	32	NU3125L	CM73LP	MS2111	25 IP
1098814	NRR3225P3	32	25	32	170	32	NU3125L	CM73LP	MS2111	25 IP
<b>left hand</b>										
1098883	NRL2020K3	20	20	25	125	32	NU3125R	CM72LP	MS2111	25 IP
1098884	NRL2525M3	25	25	32	150	32	NU3125R	CM72LP	MS2111	25 IP
1098885	NRL3225P3	32	25	32	170	32	NU3125R	CM72LP	MS2111	25 IP

NOTE: NR-style toolholders are compatible with "NU" style inserts only.

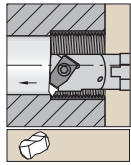

Steel shank with through coolant.

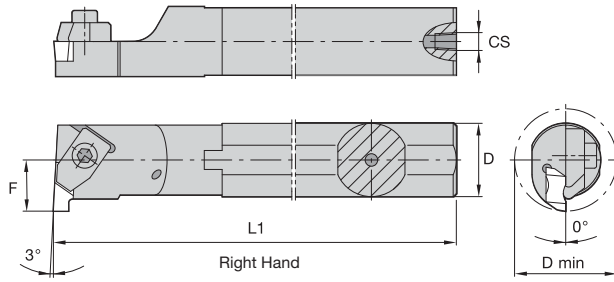

■ Steel Boring Bar • Metric

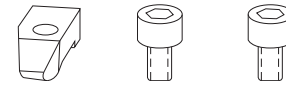

order number	catalogue number	D min	D	L1	F	CS	gage insert	clamp	clamp screw	clamp screw	hex (mm)/ Torx Plus
<b>right hand</b>											
1098945	A12MNNTOR2	18,5	12	150	11	1/16-27 NPT	—	CM147	—	MS1200	2.5 mm
1098947	A16MNNTOR2	22,0	16	150	11	1/8-27 NPT	N.2L	CM75	—	MS1200	T10
1098949	A20QNNTOR2	26,0	20	180	13	1/8-27 NPT	N.2L	CM75	—	MS1200	2.5 mm
1098951	A25RNNTOR2	34,0	25	200	17	1/4-18 NPT	N.2L	CM75	—	MS1200	2.5 mm
1098953	A25RNNTOR3	34,0	25	200	17	1/8 - 27 NPT	N.3L	CM73LP	MS2111	—	25 IP
1098955	A32SNNTOR3	44,0	32	250	22	1/4-18 NPT	N.3L	CM73LP	MS2111	—	25 IP
1098957	A40TNNTOR3	54,0	40	300	27	1/4-18 NPT	N.3L	CM73LP	MS2111	—	25 IP
1099001	A40TNNTOR4	54,0	40	300	27	1/4-18 NPT	N.4L	CM73LP	MS2111	—	25 IP
1099003	A50UNNTOR4	70,0	50	350	35	1/4-18 NPT	N.4L	CM73LP	MS2111	—	25 IP
<b>left hand</b>											
1098946	A12MNNTOL2	18,5	12	150	11	1/16-27 NPT	NG2R	CM146	—	MS1200	2.5 mm
1098948	A16MNNTOL2	22,0	16	150	11	1/8-27 NPT	N.2R	CM74	—	MS1200	T10
1098950	A20QNNTOL2	26,0	20	180	13	1/8-27 NPT	NG2R	CM74	—	MS1200	2.5 mm
1098952	A25RNNTOL2	34,0	25	200	17	1/4-18 NPT	N.2R	CM74	—	MS1200	2.5 mm
1098954	A25RNNTOL3	34,0	25	200	17	1/4-18 NPT	N.3R	CM72LP	MS2111	—	25 IP
1098956	A32SNNTOL3	44,0	32	250	22	1/4-18 NPT	N.3R	CM72LP	MS2111	—	25 IP
1098958	A40TNNTOL3	54,0	40	300	27	1/4-18 NPT	N.3R	CM72LP	MS2111	—	25 IP
1099002	A40TNNTOL4	54,0	40	300	27	1/4-18 NPT	N.4R	CM72LP	MS2111	—	25 IP

NOTE: Minimum bore capability varies with depth of groove. See page C172 for details.

Grooving and Cut-Off

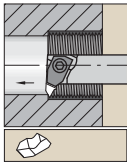

Necked steel shank with through coolant.

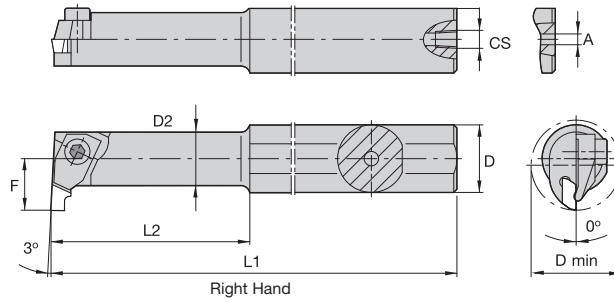

■ **Steel Boring Bar • Small ID • Metric**



order number	catalogue number	D min	D	D2	L1	L2	F	A	CS	gage insert	clamp	clamp screw	hex (mm)
<b>right hand</b>													
1098944	A12MNNTOR1	11,5	12	10,0	150	31,30	7	4,0	1/16-27 NPT	N.1L	CM109	MS1034	1.5 mm
1098943	A10KNNTOR1	11,5	10	10,0	125	—	7	3,2	—	NG1L	CM109	MS1034	1.5 mm

NOTE: Minimum bore capability varies with depth of groove. See page C172 for details.

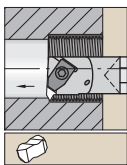

Carbide shank with through coolant.

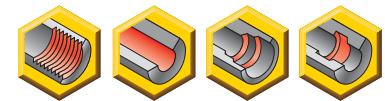
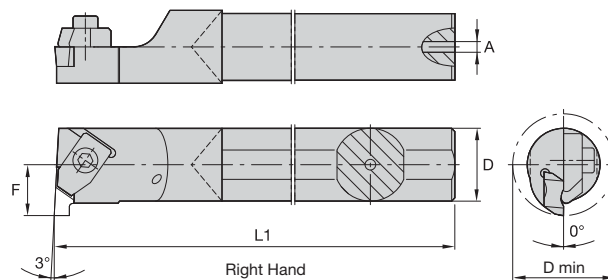

■ **Carbide Boring Bar**



order number	catalogue number	D min	D	L1	F	A	gage insert	clamp	clamp screw	Torx/ Torx Plus
<b>right hand</b>										
1152834	E16RNNTOR2	22,0	16	200	11	5,537	N.2L	CM75	MS1200	T10
1152836	E20SNNTOR2	26,0	20	250	13	7,137	N.2L	CM75	MS1200	T10
<b>left hand</b>										
1152835	E16RNNTOL2	22,0	16	200	11	5,537	N.2R	CM74	MS1200	T10

NOTE: Minimum bore capability varies with depth of groove. See page C172 for details.

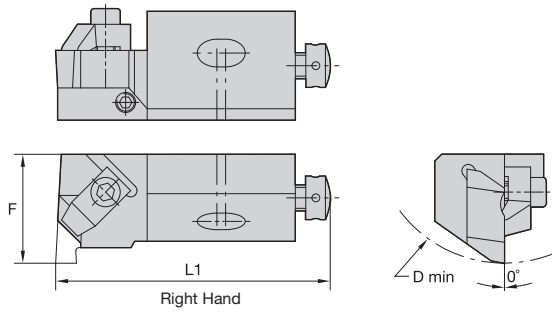
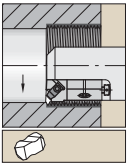

Grooving and Cut-Off

### Steel Boring Cartridge



order number	catalogue number	D min	F	L1	gage insert	clamp	clamp screw	hex (mm)	radial adjusting screw	hex (mm)	axial screw	hex (mm)	washer
<b>right hand</b>													
1098380	NER12CA2	50	20	55,7	N.2L	CM75	MS1025	2.5 mm	KUAM23	2.5 mm	KUAM31	2.5 mm	CSWM 060 050
<b>left hand</b>													
1098624	NEL12CA2	50	20	55,0	N.2R	CM74	MS1025	2.5 mm	KUAM23	2.5 mm	KUAM31	2.5 mm	CSWM 060 050
1098626	NEL25CA3	100	32	100,0	N.3R	CM72LP	MS412	4 mm	KUAM26	4 mm	KUAM33	4 mm	CSWM 100 080

NOTE: Minimum bore diameter (D min) capability varies with thread type and pitch. See page C172 for details.  
F dimension measured over sharp point of Top Notch-style threading insert.

**Machining Guidelines for Chip Control • Grooving**

When the proper cutter diameter is not available, proper cutter positioning will provide positive results.

- Centre height of insert should be positioned at the centre of the workpiece or up to 0,13mm (.005") above.
- Dwell time in the bottom of the groove (more than three revolutions) is not recommended.
- Chip control is feed rate related and should be adjusted to fit the particular situation. Recommended feed range is 0,08–0,3 mm/rev (.003–.012 IPR).

**Groove Limits (Maximum Internal Groove Depth vs. Minimum Bore Diameter)**

insert catalogue number	maximum internal groove depth mm	minimum bore diameter mm
NG-1094L	1,91	20,32
—	1,02	11,18
NG-2031R/L	1,27	18,54
NG-2041R/L	—	—
NG-2047R/L	—	—
NG-2058R/L	—	—
—	2,79	63,50
NG-2062R/L	2,59	44,45
NG-2094R/L	2,49	38,10
NG-2125R/L	2,03	25,40
—	1,40	18,54
NG-3047R/L	—	—
NG-3062R/L	2,39	44,45
NG-3072R/L	2,29	41,28
NG-3078R/L	1,91	34,93
NG-3088R/L	—	—
NG-3094R/L	—	—
NG-3097R/L	3,81	60,33
NG-3105R/L	—	—
NG-3110R/L	3,68	53,98
NG-3122R/L	—	—
NG-3125R/L	3,51	47,63
NG-3142R/L	—	—
NG-3156R/L	3,18	41,28
NG-3178R/L	—	—
NG-3185R/L	2,79	34,93
NG-3189R/L	—	—
NG-4125R/L	3,81	69,85
—	6,35	146,05
NG-4189R/L	6,22	127,00
NG-4213R/L	6,10	114,30
NG-4219R/L	5,54	82,55
NG-4250R/L	5,08	63,50

NOTE: The same maximum groove depth and minimum bore diameter values also apply to metric, NG-K (chip control), and NR (full radius) inserts of similar size.

**Machining Guidelines for Chip Control • Turning/Profiling**

Maximum depth of cut for side cutting (turning/profiling) depends on the material being cut and the width of the tool.

- 0,79–1,6mm (.031–.062") wide insert can cut up to 0,6mm (.025" deep).
- 1,7–3,3mm (.067–.128") wide insert can cut up to 1mm (.040" deep).
- 3,5–4,8mm (.138–.189") wide insert can cut up to 2mm (.080" deep).
- 5–6,35mm (.197–.250") wide insert can cut up to 3mm (.120" deep).

**Finish Turning the Groove**

1. Plunge both sides of groove width.
2. Plunge centre area to remove web of material remaining.
3. To avoid insert chipping and to achieve groove wall perpendicularity, follow the tool path outlined.
4. Use the lightest depth of cut that still allows good chipbreaking, tool life, and surface finish.

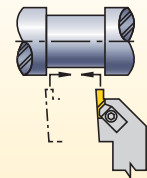

insert catalogue number	maximum internal groove depth mm	minimum bore diameter mm
—	9,53	731,82
NG-5250R/L	9,17	401,62
NG-5281R/L	8,74	274,62
NG-5312R/L	8,31	185,72
NG-5344R/L	7,47	122,22
NG-5375R/L	6,53	90,47
—	5,46	71,42
NG-6250R/L	6,35	146,05
NG-6281R/L	6,22	127,00
NG-6312R/L	6,10	114,30
NG-6344R/L	5,54	82,55
NG-6375R/L	5,08	63,50

**Internal Groove Depth versus Bar Interference**

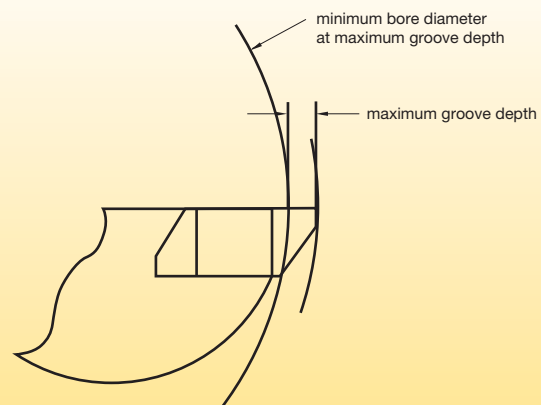

NOTE: Internal grooving depth limits are a function of bar clearance versus bore diameters.

■ Machining Guidelines for Face Grooving Operations • External

Standard NF/NDF Inserts

insert family	maximum groove depth "B"	minimum groove diameter "C"
	mm	mm
NF-3	1,52	23,90
NF-3	2,39	30,50
NF-3	3,18	36,10
NF-3	3,81	41,30
NFD-3	6,35	47,60
NF-4/6	1,52	23,90
NF-4/6	2,39	30,50
NF-4/6	3,18	36,10
NF-4/6	3,81	41,30
NF-4/6	4,78	47,60
NF-4/6	6,35	57,20
NFD-4	9,53	57,20
NFD-4	12,70	57,20

Toolholders

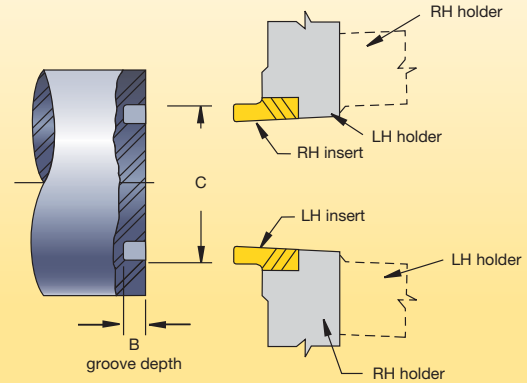

Standard NG/NGD Inserts

insert family	maximum groove depth "B"	minimum groove diameter "C"
	mm	mm
NG-2	1,27	54,0
NG-2	2,79	88,9
NG-3	2,39	101,6
NG-3	3,18	127,0
NG-3	3,81	139,7
NGD-3	6,35	174,6
NG-4	3,81	152,4
NG-4	6,35	209,6
NGD-4	9,53	222,3
NGD-4	12,70	222,3
NG-5	9,53	333,0

Boring Bars

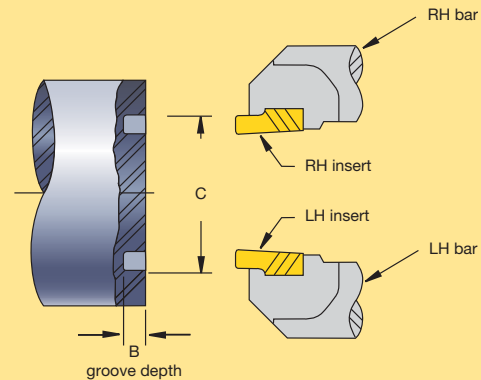

■ Machining Guidelines for Face Grooving Operations • Internal

insert family	maximum groove depth "D"	minimum groove diameter "E"
	mm	mm
NFD-3-KI	6,35	57,2

NOTE: For internal applications, use only NFD-KI inserts.

Boring Bars

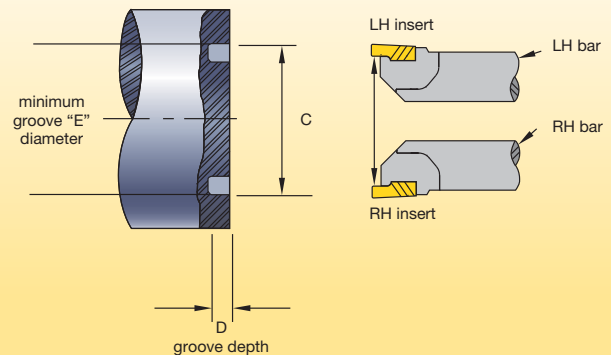

### ■ Tool Application Guidelines

- Always use good general machining practices.
- Make the machine and workpiece setup as rigid as possible.
- Integral shank toolholders offer the best rigidity. They should be your first toolholder choice, when possible.
- Use the toolholder with the shortest possible depth of cut for the application ("CD" dimension).
- When changing inserts, make sure the new insert locates securely against the toolholder's positive stop.
- Never tighten the clamping screw without an insert in the pocket.
- Toolholder projection out of the tool block should be as short as possible.
- Inserts should cut as close to centre as possible.
- Dwell time in bottom of groove should be less than three revolutions.
- Recommended cutting speed and feeds are a starting point. Adjust, as necessary, for optimum tool life and chip control.

### Definitions and Guidelines

1. Width of cut (W) = width of the insert.
2. Lead angle = 0° (neutral); 6° (RH or LH).

#### Reduce bur of cut-off faces:

- Use lead angle-type inserts (Figures 1 and 2). Lead angle on a cut-off insert reduces the bur that remains on the part but decreases tool life and increases tool side deflection and possibly cycle time.
- If 0° lead angle is mandatory, use the narrowest possible cut-off insert and blade. This will minimise the centre stub or cut-off bur length.

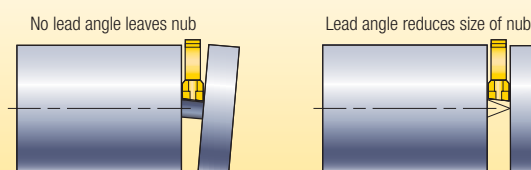

**Figure 1**

Insert selection **left-hand lead**

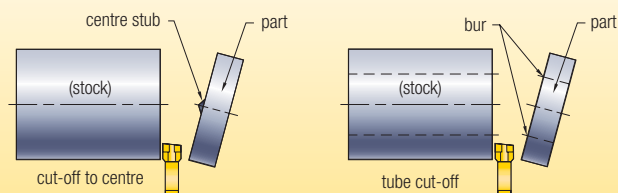

Left-hand lead insert leaves centre stub or bur on part and produces clean stock surface.

**Figure 2**

Insert selection **right-hand lead**

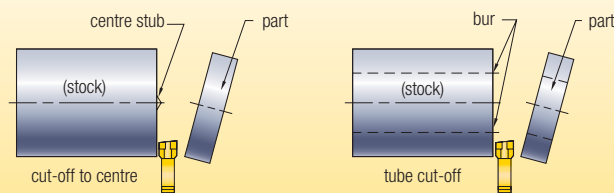

Reduces nub but decreases tool life and productivity

Right-hand lead insert leaves centre stub or bur on stock and produces clean part surface.

- Check total height and maintain on centre with part diameter.
- The cutting edge height should be within  $\pm 0,1\text{mm}$  (.004") to the centre; recommended cutting position is 0,05mm (.002") above centre.

### ■ Tubing

- On tubing-type parts that require a chamfer on the I.D., align I.D. chamfer tool with cut-off surface. This will enable the chamfering operation to actually separate the part from the bar (see Figure 3). Note the part may drop onto the chamfering bar, which, in this case, will act like a catcher for the part.

Figure 3

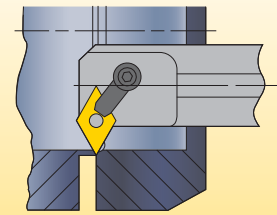

Internal chamfer line up

#### Improve surface finish of cut-off faces:

- Use insert with 0° lead angle.
- Increase coolant flow or improve application technique, as shown in Figure 4.
- Decrease the feed rate near the break-through point of the cut.
- Check that the grooving tool is set at the correct angle.
- Use blades with the greatest possible face height and smallest possible cutting width.
- Increase the speed.

Figure 4

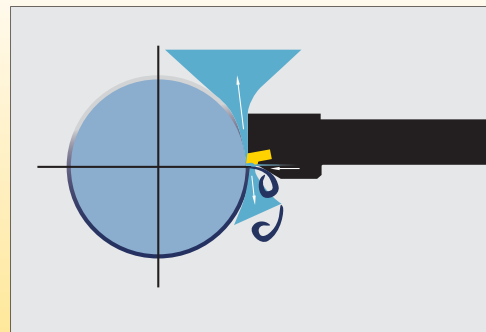

#### Preferred method for applying coolant

- Mount cut-off tool upside down. This enables gravity to remove chips and avoid cutting the chips twice. Another benefit of mounting the tool upside down is preventing chips from wedging between the tool insert and the groove side walls, which galls the side wall surfaces.

### ■ Programming Guidelines

#### Feed reduction in cut-off

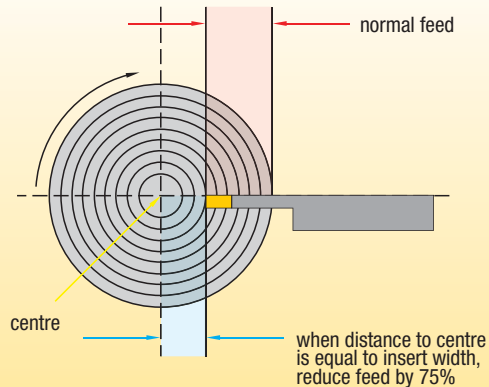

#### Chamfering

Chamfering with a grooving tool reduced machine index time and tool stations.

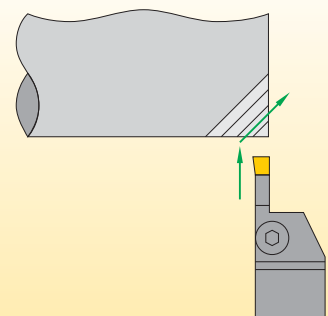

(continued)



■ Programming Guidelines (continued)

**Pocketing**

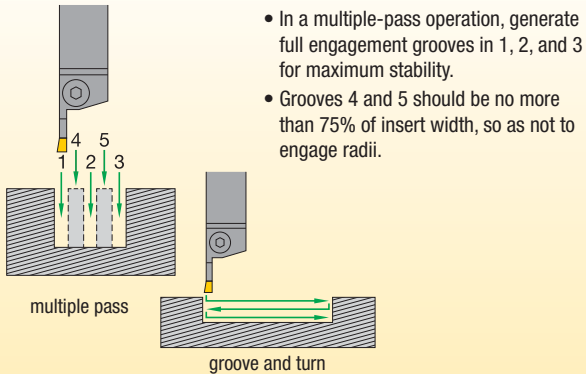

- In a multiple-pass operation, generate full engagement grooves in 1, 2, and 3 for maximum stability.
- Grooves 4 and 5 should be no more than 75% of insert width, so as not to engage radii.

If pocket is deeper than wide = multiple pass

If pocket is wider than deep = groove and turn

**Square Pocket**

**Steps 1 and 2**

Plunge the radius and wall on each side to open up two grooves.

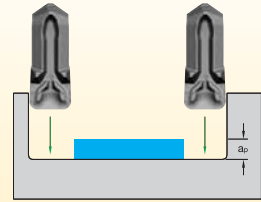

**Step 3**

Retract tool 0,1mm; this is necessary to create a flat bottom.



**Step 4**

Side turn. This tool is designed to deflect, creating the necessary front clearance.

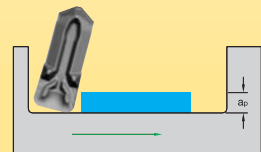

**Profile Pocket**

**Step 1**

Rough to have about the same amount of stock left on all surfaces for finish.

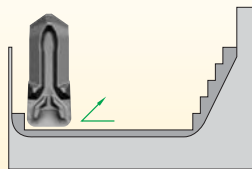

**Step 2**

Open up two grooves away from wall and radius.

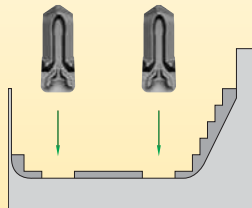

**Step 3**

(1 and 2) Finish wall and radius.  
(3 and 4) Finish wall, angle, and radius on opposite side of pocket.  
(5) Retract tool 0,1mm (.004").  
(6) Side turn to finish the floor of the pocket.

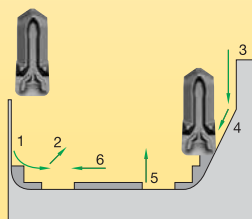

**Generating a Radius**

**Step 1**

Open up a groove away from the radius.

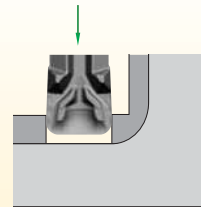

**Step 2**

Retract and move the material on the wall and generate the radius. By generating the groove in the prior step, only one surface is engaged at a time, reducing the risk of vibrations.

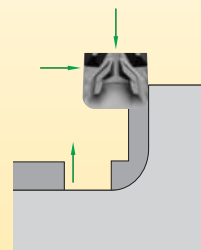

**Step 3**

Retract the tool 0,1mm (.004") and then side turn.

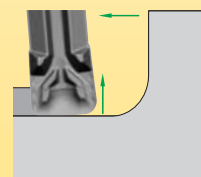

## Grooving Tool Failure and Solution Guide

### Face Grooving Application Guidelines

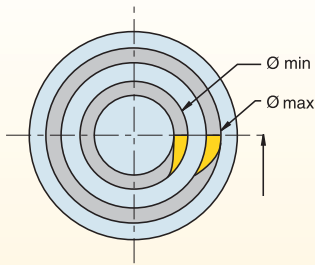

#### Tool Selection

- When selecting the toolholder, always start at the largest diameter possible and work toward the smaller diameter. This will allow the strongest tool to be used.

#### Cutting the First Groove

- The outside diameter of the first groove must be between the diameter minimum and diameter maximum capability of the face grooving tool (see illustration above). This creates clearance for the toolholder.

#### Chip Control

- Adjust speed and feed for good chip control and evacuation from the groove. Chip compaction can cause poor surface finish, tool breakage, and reduced tool life.

#### Tool Setting

- The tool should be set as close to the centre as possible to avoid extreme formation of burrs.
- Align the cutting edge square to the workpiece.

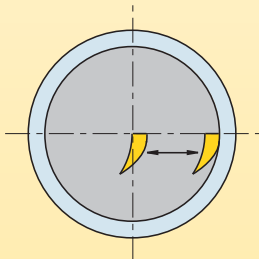

#### Widening a Face Groove

- After the first groove has been cut, the groove width can be widened in either direction using the same tool. The best practice is to work from the O.D. to the I.D.

### Practical Solutions to Grooving Problems

problem	remedy
bur	<ol style="list-style-type: none"> <li>1. Verify tool centre height.</li> <li>2. Use sharp tools (index more often).</li> <li>3. Use positive rake PVD coated insert.</li> <li>4. Use correct grade for workpiece material.</li> <li>5. Use correct geometry (e.g., positive rake for workhardening material).</li> <li>6. Change tool path.</li> </ol>
poor surface finish	<ol style="list-style-type: none"> <li>1. Increase speed.</li> <li>2. Use sharp tools (index more often).</li> <li>3. Dwell time in bottom 1–3 revolutions (max).</li> <li>4. Use proper chip control geometry.</li> <li>5. Increase coolant flow.</li> <li>6. Verify proper setup (overhang, shank size).</li> <li>7. Use correct geometry (e.g., positive rake for workhardening material).</li> </ol>
groove bottom not flat	<ol style="list-style-type: none"> <li>1. Use sharp tools (index more often).</li> <li>2. Dwell time in bottom 1–3 revolutions (max).</li> <li>3. Reduce tool overhang (increase rigidity).</li> <li>4. Reduce feed rate at groove bottom.</li> <li>5. Use a wider insert.</li> <li>6. Verify tool centre height.</li> </ol>
poor chip control	<ol style="list-style-type: none"> <li>1. Use sharp tools (index more often).</li> <li>2. Increase coolant concentration.</li> <li>3. Adjust feed rate (usually increase first).</li> </ol>
chatter	<ol style="list-style-type: none"> <li>1. Reduce tool and workpiece overhang.</li> <li>2. Adjust speed (usually increase first).</li> <li>3. Adjust feed (usually increase first).</li> <li>4. Verify tool centre height.</li> </ol>
insert chipping	<ol style="list-style-type: none"> <li>1. Use correct grade for workpiece material.</li> <li>2. Increase speed.</li> <li>3. Reduce feed.</li> <li>4. Use a stronger grade.</li> <li>5. Increase tool and setup rigidity.</li> </ol>
built-up edge	<ol style="list-style-type: none"> <li>1. Use positive rake PVD coated insert.</li> <li>2. Increase speed.</li> <li>3. Reduce feed.</li> <li>4. Increase coolant flow/concentration.</li> <li>5. Use cermets.</li> </ol>
side walls not straight	<ol style="list-style-type: none"> <li>1. Check tool alignment for square.</li> <li>2. Reduce workpiece and tool overhang.</li> <li>3. Use sharp inserts (index more often).</li> </ol>

**Steps to proper face grooving tool selection**

- Step 1: Select your spindle rotation
- Step 2: Select your angle of approach and toolholder orientation

**Integral Tooling**

Anti-Clockwise Rotation  
Square Shank

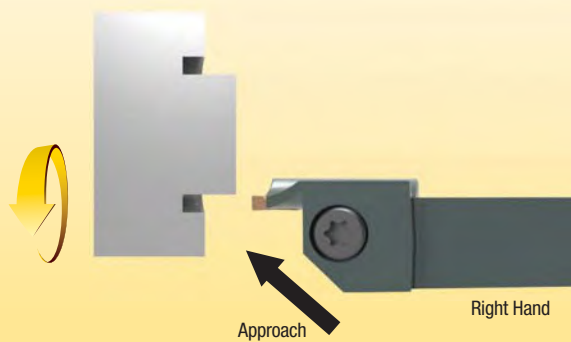

Clockwise Rotation  
Square Shank

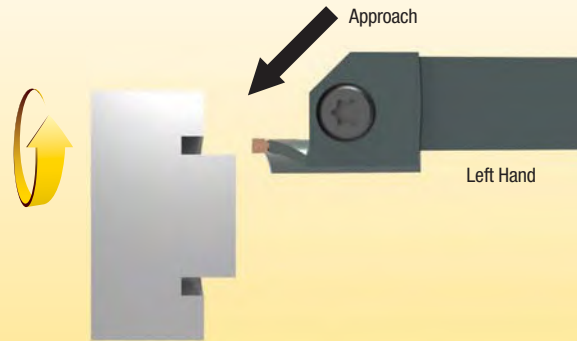

Boring Bar

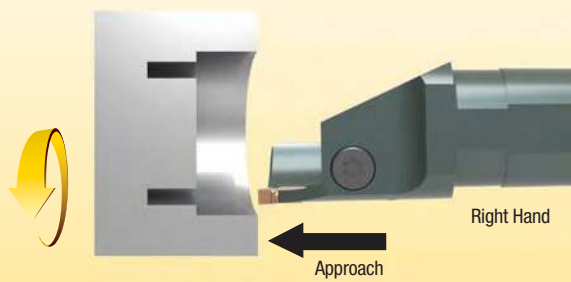

Boring Bar

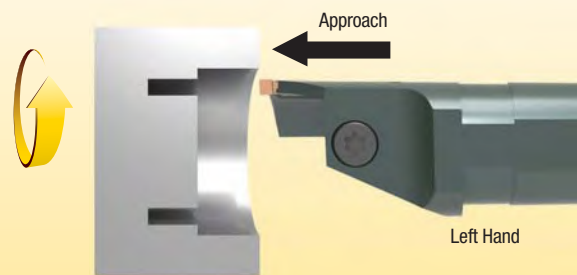

**Steps to proper modular face grooving tool selection**

- Step 1: Select your spindle rotation
- Step 2: Select your angle of approach and toolholder orientation
- Step 3: Identify combination of blade and shank tool

**Modular Tooling**

